



<b>MiniSKiiP® 2 PIM</b>	<b>1200V / 35A</b>				
<table border="1" style="width: 100%; border-collapse: collapse;"> <tr style="background-color: #000080; color: white;"> <th style="padding: 2px;">Features</th> </tr> <tr> <td style="padding: 2px;"> <ul style="list-style-type: none"> <li>Solderless interconnection</li> <li>Trench Fieldstop IGBT4 technology</li> </ul> </td> </tr> </table>	Features	<ul style="list-style-type: none"> <li>Solderless interconnection</li> <li>Trench Fieldstop IGBT4 technology</li> </ul>	<table border="1" style="width: 100%; border-collapse: collapse;"> <tr style="background-color: #000080; color: white;"> <th style="padding: 2px;">MiniSKiiP® 2 housing</th> </tr> <tr> <td style="text-align: center; padding: 5px;">  </td> </tr> </table>	MiniSKiiP® 2 housing	
Features					
<ul style="list-style-type: none"> <li>Solderless interconnection</li> <li>Trench Fieldstop IGBT4 technology</li> </ul>					
MiniSKiiP® 2 housing					
					
<table border="1" style="width: 100%; border-collapse: collapse;"> <tr style="background-color: #000080; color: white;"> <th style="padding: 2px;">Target Applications</th> </tr> <tr> <td style="padding: 2px;"> <ul style="list-style-type: none"> <li>Industrial Motor Drives</li> </ul> </td> </tr> </table>	Target Applications	<ul style="list-style-type: none"> <li>Industrial Motor Drives</li> </ul>	<table border="1" style="width: 100%; border-collapse: collapse;"> <tr style="background-color: #000080; color: white;"> <th style="padding: 2px;">Schematic</th> </tr> <tr> <td style="text-align: center; padding: 5px;">  </td> </tr> </table>	Schematic	
Target Applications					
<ul style="list-style-type: none"> <li>Industrial Motor Drives</li> </ul>					
Schematic					
					
<table border="1" style="width: 100%; border-collapse: collapse;"> <tr style="background-color: #000080; color: white;"> <th style="padding: 2px;">Types</th> </tr> <tr> <td style="padding: 2px;"> <ul style="list-style-type: none"> <li>V23990-K220-A40-PM</li> </ul> </td> </tr> </table>	Types	<ul style="list-style-type: none"> <li>V23990-K220-A40-PM</li> </ul>			
Types					
<ul style="list-style-type: none"> <li>V23990-K220-A40-PM</li> </ul>					

### Maximum Ratings

$T_j=25^{\circ}\text{C}$ , unless otherwise specified

Parameter	Symbol	Condition	Value	Unit
<b>D8,D9,D10,D11,D12,D13</b>				
Repetitive peak reverse voltage	$V_{RRM}$		1600	V
DC forward current	$I_{FAV}$	$T_j=T_{jmax}$ $T_n=80^{\circ}\text{C}$	37	A
Surge forward current	$I_{FSM}$	$t_p=10\text{ms}$ $T_j=150^{\circ}\text{C}$	270	A
$I^2t$ -value	$I^2t$		360	$\text{A}^2\text{s}$
Power dissipation per Diode	$P_{tot}$	$T_j=T_{jmax}$ $T_n=80^{\circ}\text{C}$	56	W
Maximum Junction Temperature	$T_{jmax}$		150	$^{\circ}\text{C}$
<b>T1,T2,T3,T4,T5,T6,T7</b>				
Collector-emitter break down voltage	$V_{CE}$		1200	V
DC collector current	$I_C$	$T_j=T_{jmax}$ $T_n=80^{\circ}\text{C}$	38	A
Repetitive peak collector current	$I_{Cpulse}$	$t_p$ limited by $T_{jmax}$	105	A
Power dissipation per IGBT	$P_{tot}$	$T_j=T_{jmax}$ $T_n=80^{\circ}\text{C}$	96	W
Gate-emitter peak voltage	$V_{GE}$		$\pm 20$	V
Short circuit ratings	$t_{SC}$ $V_{CC}$	$T_j \leq 150^{\circ}\text{C}$ $V_{GE} = 15\text{V}$	10 800	$\mu\text{s}$ V
Maximum Junction Temperature	$T_{jmax}$		175	$^{\circ}\text{C}$

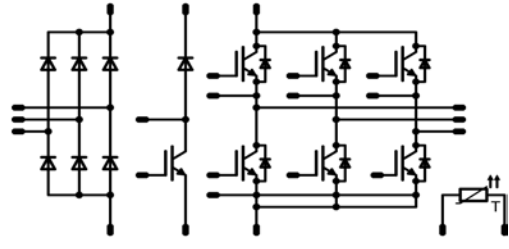
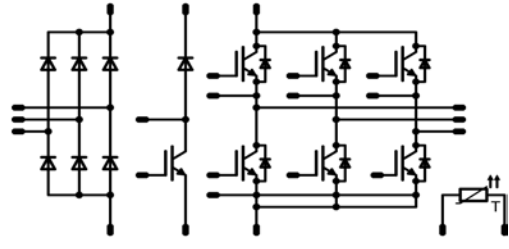
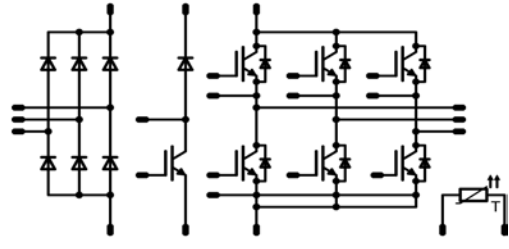
## Maximum Ratings

 $T_j=25^{\circ}\text{C}$ , unless otherwise specified

Parameter	Symbol	Condition	Value	Unit
<b>D1,D2,D3,D4,D5,D6,D7</b>				
Peak Repetitive Reverse Voltage	$V_{RRM}$		1200	V
DC forward current	$I_F$	$T_j=T_{jmax}$ $T_h=80^{\circ}\text{C}$	33	A
Repetitive peak forward current	$I_{FRM}$	$t_p=10\text{ms}$ half sine	225	A
Power dissipation per Diode	$P_{tot}$	$T_j=T_{jmax}$ $T_h=80^{\circ}\text{C}$	77	W
Maximum Junction Temperature	$T_{jmax}$		175	$^{\circ}\text{C}$

### Thermal Properties

Storage temperature	$T_{stg}$		-40...+125	$^{\circ}\text{C}$
Operation temperature under switching condition	$T_{op}$		-40...+( $T_{jmax} - 25$ )	$^{\circ}\text{C}$

### Insulation Properties

Insulation voltage	$V_{is}$	$t=2\text{s}$ DC voltage	4000	V
Creepage distance			min 12.7	mm
Clearance			min 12.7	mm

**Characteristic Values**

Parameter	Symbol	Conditions					Value			Unit
		$V_{GE}[V]$ or $V_{GS}[V]$	$V_r[V]$ or $V_{CE}[V]$ or $V_{DS}[V]$	$I_c[A]$ or $I_F[A]$ or $I_b[A]$	$T_j$	Min	Typ	Max		
<b>D8,D9,D10,D11,D12,D13</b>										
Forward voltage	$V_F$				25	$T_j=25^\circ\text{C}$ $T_j=125^\circ\text{C}$	0,8	1,08 1,03	1,35	V
Threshold voltage (for power loss calc. only)	$V_{th}$					$T_j=25^\circ\text{C}$ $T_j=125^\circ\text{C}$		0,89 0,78		V
Slope resistance (for power loss calc. only)	$r_t$					$T_j=25^\circ\text{C}$ $T_j=125^\circ\text{C}$		7,56 10,20		m $\Omega$
Reverse current	$I_r$			1500		$T_j=25^\circ\text{C}$ $T_j=125^\circ\text{C}$			0,01 1,1	mA
Thermal resistance chip to heatsink per chip	$R_{thJH}$	Thermal grease thickness $\leq 50\mu\text{m}$ $\lambda=1\text{W/mK}$						1,25		K/W

**T1,T2,T3,T4,T5,T6,T7**

Gate emitter threshold voltage	$V_{GE(th)}$	$V_{CE}=V_{GE}$			0,0012	$T_j=25^\circ\text{C}$ $T_j=150^\circ\text{C}$	5	5,8	6,5	V	
Collector-emitter saturation voltage	$V_{CE(sat)}$		15		35	$T_j=25^\circ\text{C}$ $T_j=150^\circ\text{C}$	1,6	1,87 2,3	2,15	V	
Collector-emitter cut-off current incl. diode	$I_{CES}$		0	1200		$T_j=25^\circ\text{C}$ $T_j=150^\circ\text{C}$			0,05	mA	
Gate-emitter leakage current	$I_{GES}$		20	0		$T_j=25^\circ\text{C}$ $T_j=150^\circ\text{C}$			300	nA	
Integrated Gate resistor	$R_{gint}$							-		$\Omega$	
Turn-on delay time	$t_{d(on)}$	$R_{goff}=16\Omega$ $R_{gon}=16\Omega$	$\pm 15$	600	35	$T_j=25^\circ\text{C}$		78		ns	
Rise time	$t_r$					$T_j=150^\circ\text{C}$		79			
Turn-off delay time	$t_{d(off)}$					$T_j=25^\circ\text{C}$		24			
Fall time	$t_f$					$T_j=150^\circ\text{C}$		29			
Turn-on energy loss per pulse	$E_{on}$					$T_j=25^\circ\text{C}$		196			
Turn-off energy loss per pulse	$E_{off}$	$T_j=150^\circ\text{C}$		268							
Input capacitance	$C_{ies}$	$f=1\text{MHz}$	0	25		$T_j=25^\circ\text{C}$		1950		pF	
Output capacitance	$C_{oss}$						$T_j=25^\circ\text{C}$		155		
Reverse transfer capacitance	$C_{rss}$								115		
Gate charge	$Q_{Gate}$	$V_{cc}=960\text{V}$	15		40	$T_j=25^\circ\text{C}$		192		nC	
Thermal resistance chip to heatsink per chip	$R_{thJH}$	Thermal grease thickness $\leq 50\mu\text{m}$ $\lambda=1\text{W/mK}$						1		K/W	

**D1,D2,D3,D4,D5,D6,D7**

Diode forward voltage	$V_F$				35	$T_j=25^\circ\text{C}$ $T_j=150^\circ\text{C}$	1,5	2,36 2,34	2,65	V
Peak reverse recovery current	$I_{RRM}$	$R_{gon}=16\Omega$	$\pm 15$	600	35	$T_j=25^\circ\text{C}$		16		A
Reverse recovery time	$t_{rr}$					$T_j=150^\circ\text{C}$		22,6		
Reverse recovered charge	$Q_{rr}$					$T_j=25^\circ\text{C}$		336		
Peak rate of fall of recovery current	$di(\text{rec})_{\text{max}}/dt$					$T_j=150^\circ\text{C}$		550		
Reverse recovered energy	$E_{rec}$					$T_j=25^\circ\text{C}$		2,2		
		$T_j=150^\circ\text{C}$		5,36						
		$T_j=25^\circ\text{C}$		63						
		$T_j=150^\circ\text{C}$		67						
		$T_j=25^\circ\text{C}$		0,77						
		$T_j=150^\circ\text{C}$		2,07						
Thermal resistance chip to heatsink per chip	$R_{thJH}$	Thermal grease thickness $\leq 50\mu\text{m}$ $\lambda=1\text{W/mK}$						1,2		K/W

**Thermistor**

Rated resistance	R					$T=25^\circ\text{C}$		1000		$\Omega$
Deviation of R100	$\Delta R/R$	$R_{100}=1670\Omega$				$T=100^\circ\text{C}$	-3		3	%
R100	P					$T=100^\circ\text{C}$		1670,313		$\Omega$
Power dissipation constant						$T=25^\circ\text{C}$				mW/K
A-value	B(25/50)	Tol. %				$T=25^\circ\text{C}$		$7,635 \cdot 10^{-3}$		1/K
B-value	B(25/100)	Tol. %				$T=25^\circ\text{C}$		$1,731 \cdot 10^{-5}$		1/K <sup>2</sup>
Vincotech NTC Reference									E	

**T1,T2,T3,T4,T5,T6,T7/D1,D2,D3,D4,D5,D6,D7**
**Figure 1** T1,T2,T3,T4,T5,T6,T7 IGBT

**Typical output characteristics**

$I_C = f(V_{CE})$

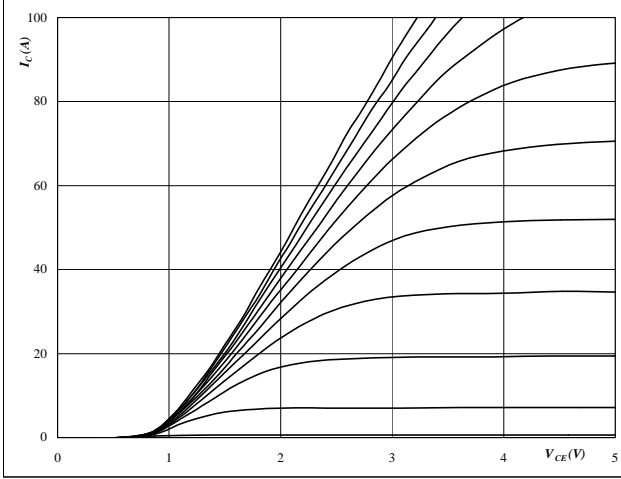

**At**  
 $t_p = 250 \text{ } \mu\text{s}$   
 $T_j = 25 \text{ } ^\circ\text{C}$   
 $V_{GE}$  from 7 V to 17 V in steps of 1 V

**Figure 2** T1,T2,T3,T4,T5,T6,T7 IGBT

**Typical output characteristics**

$I_C = f(V_{CE})$

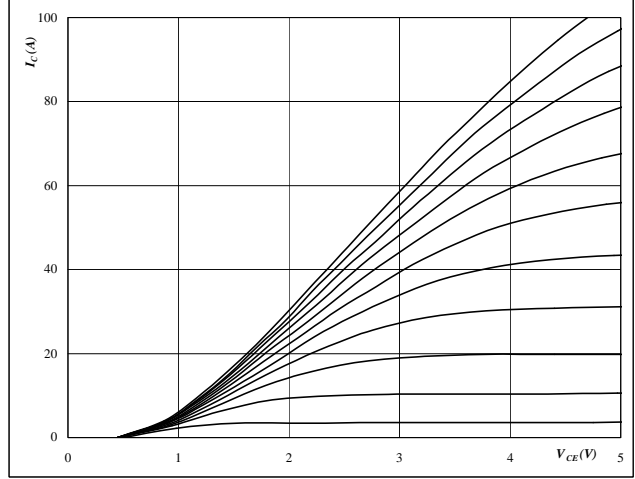

**At**  
 $t_p = 250 \text{ } \mu\text{s}$   
 $T_j = 150 \text{ } ^\circ\text{C}$   
 $V_{GE}$  from 7 V to 17 V in steps of 1 V

**Figure 3** T1,T2,T3,T4,T5,T6,T7 IGBT

**Typical transfer characteristics**

$I_C = f(V_{GE})$

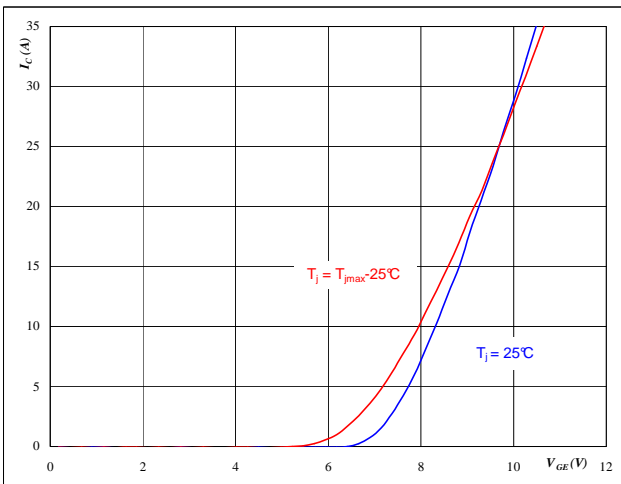

**At**  
 $t_p = 250 \text{ } \mu\text{s}$   
 $V_{CE} = 10 \text{ V}$

**Figure 4** D1,D2,D3,D4,D5,D6,D7 FWD

**Typical diode forward current as a function of forward voltage**

$I_F = f(V_F)$

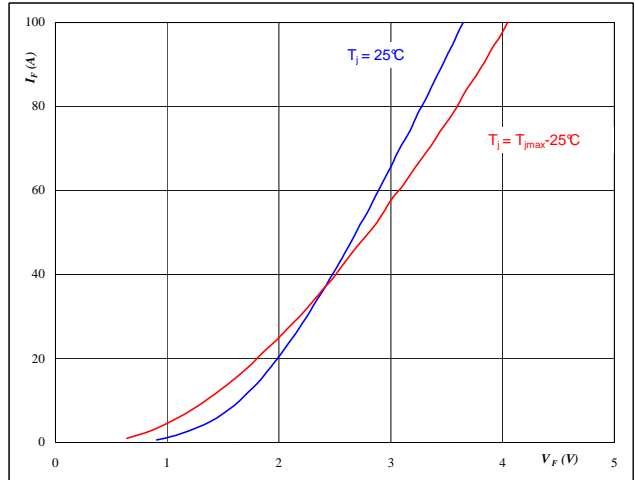

**At**  
 $t_p = 250 \text{ } \mu\text{s}$

**T1,T2,T3,T4,T5,T6,T7/D1,D2,D3,D4,D5,D6,D7**
**Figure 5** T1,T2,T3,T4,T5,T6,T7 IGBT

**Typical switching energy losses  
as a function of collector current**

$$E = f(I_C)$$

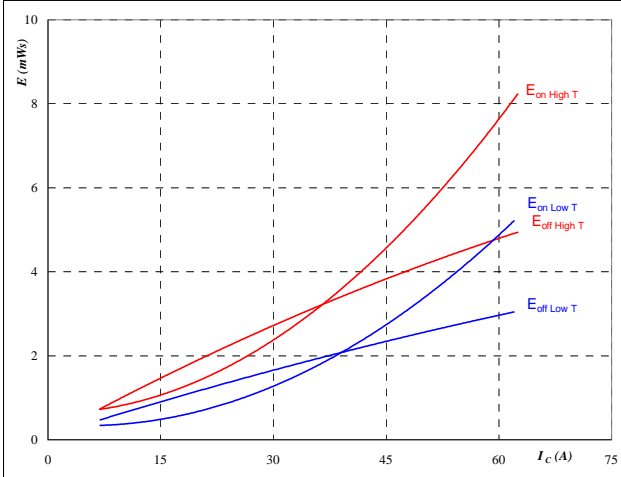

With an inductive load at

$T_J =$	25/150	°C
$V_{CE} =$	600	V
$V_{GE} =$	±15	V
$R_{gon} =$	8	Ω
$R_{goff} =$	8	Ω

**Figure 6** T1,T2,T3,T4,T5,T6,T7 IGBT

**Typical switching energy losses  
as a function of gate resistor**

$$E = f(R_G)$$

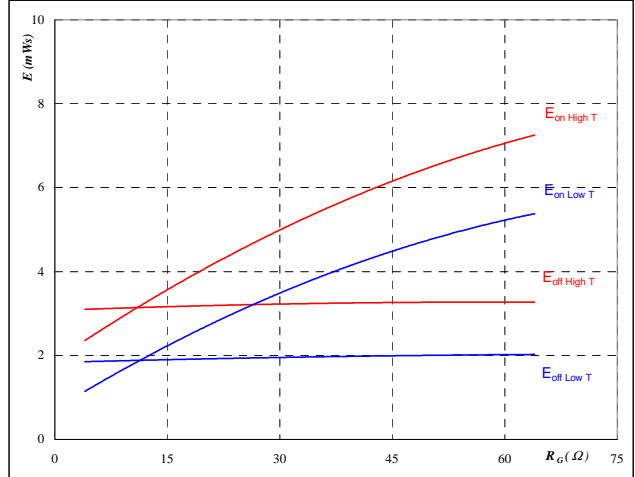

With an inductive load at

$T_J =$	25/150	°C
$V_{CE} =$	600	V
$V_{GE} =$	±15	V
$I_C =$	35	A

**Figure 7** T1,T2,T3,T4,T5,T6,T7 IGBT

**Typical reverse recovery energy loss  
as a function of collector current**

$$E_{rec} = f(I_C)$$

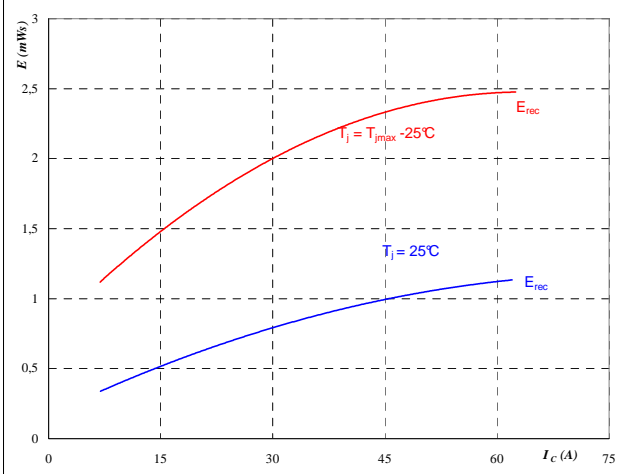

With an inductive load at

$T_J =$	25/150	°C
$V_{CE} =$	600	V
$V_{GE} =$	±15	V
$R_{gon} =$	8	Ω

**Figure 8** T1,T2,T3,T4,T5,T6,T7 IGBT

**Typical reverse recovery energy loss  
as a function of gate resistor**

$$E_{rec} = f(R_G)$$

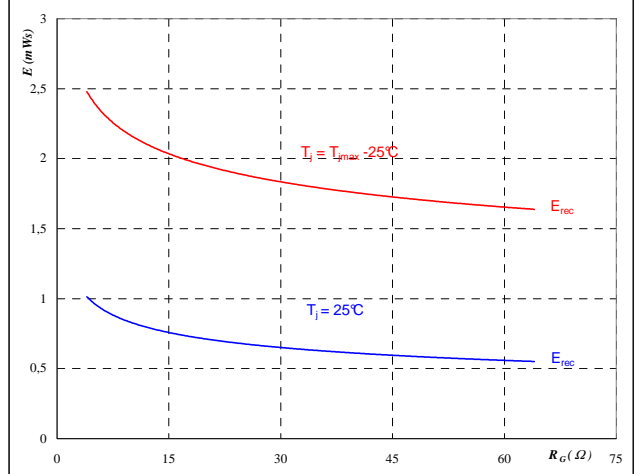

With an inductive load at

$T_J =$	25/150	°C
$V_{CE} =$	600	V
$V_{GE} =$	±15	V
$I_C =$	35	A

T1,T2,T3,T4,T5,T6,T7/D1,D2,D3,D4,D5,D6,D7

Figure 9 T1,T2,T3,T4,T5,T6,T7 IGBT

Typical switching times as a function of collector current

$t = f(I_C)$

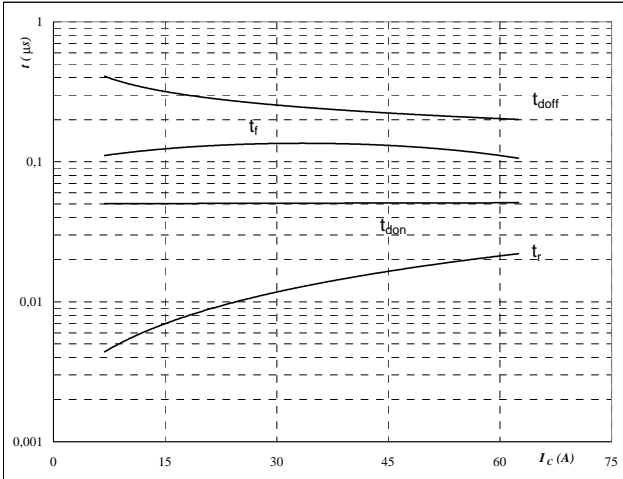

With an inductive load at

$T_J =$	150	°C
$V_{CE} =$	600	V
$V_{GE} =$	±15	V
$R_{gon} =$	8	Ω
$R_{goff} =$	8	Ω

Figure 10 T1,T2,T3,T4,T5,T6,T7 IGBT

Typical switching times as a function of gate resistor

$t = f(R_G)$

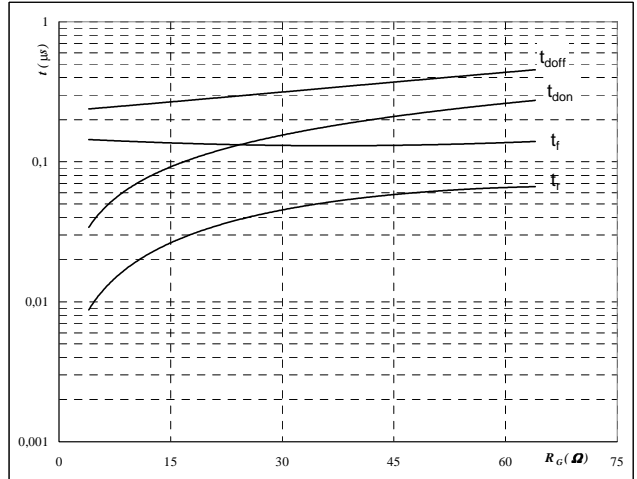

With an inductive load at

$T_J =$	150	°C
$V_{CE} =$	600	V
$V_{GE} =$	±15	V
$I_C =$	35	A

Figure 11 D1,D2,D3,D4,D5,D6,D7 FWD

Typical reverse recovery time as a function of collector current

$t_{rr} = f(I_C)$

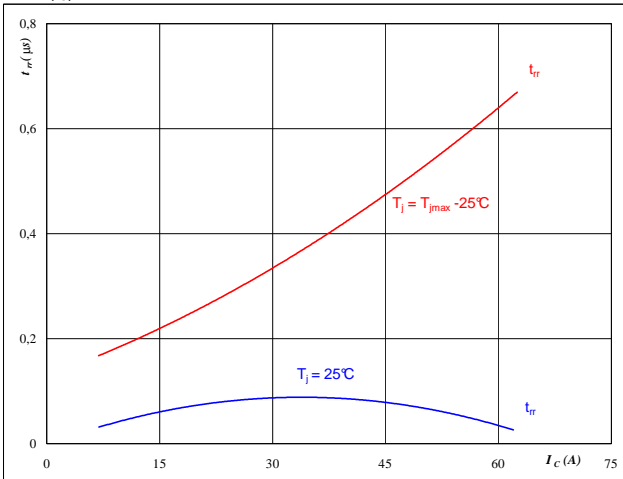

At

$T_J =$	25/150	°C
$V_{CE} =$	600	V
$V_{GE} =$	±15	V
$R_{gon} =$	8	Ω

Figure 12 D1,D2,D3,D4,D5,D6,D7 FWD

Typical reverse recovery time as a function of IGBT turn on gate resistor

$t_{rr} = f(R_{gon})$

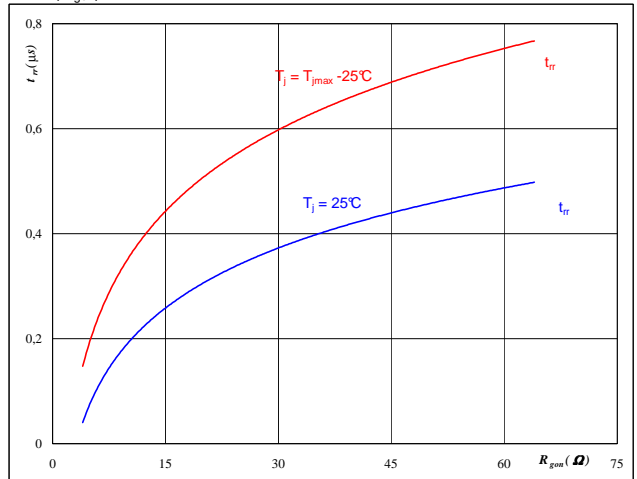

At

$T_J =$	25/150	°C
$V_R =$	600	V
$I_F =$	35	A
$V_{GE} =$	±15	V

**T1,T2,T3,T4,T5,T6,T7/D1,D2,D3,D4,D5,D6,D7**
**Figure 13** D1,D2,D3,D4,D5,D6,D7 FWD

**Typical reverse recovery charge as a function of collector current**

$Q_{rr} = f(I_C)$

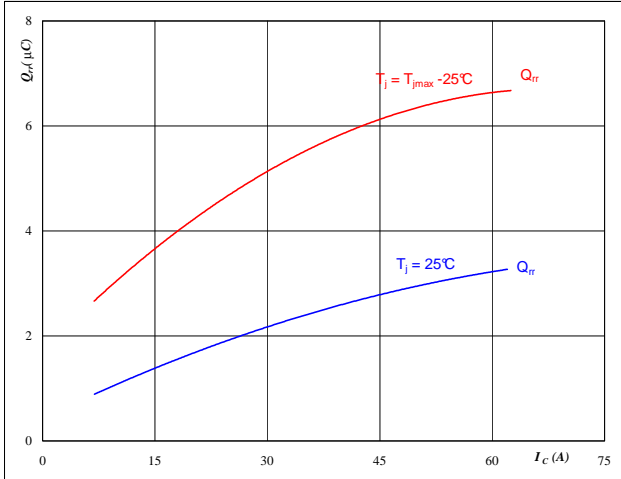

**At**

$T_j =$	25/150	$^\circ\text{C}$
$V_{CE} =$	600	V
$V_{GE} =$	$\pm 15$	V
$R_{gon} =$	8	$\Omega$

**Figure 14** D1,D2,D3,D4,D5,D6,D7 FWD

**Typical reverse recovery charge as a function of IGBT turn on gate resistor**

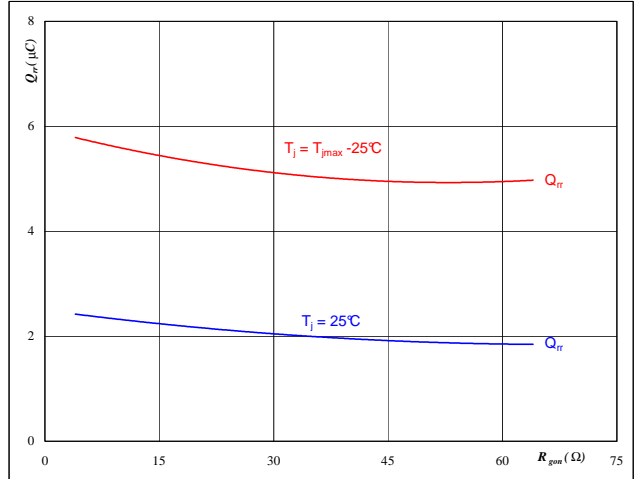
$Q_{rr} = f(R_{gon})$



**At**

$T_j =$	25/150	$^\circ\text{C}$
$V_R =$	600	V
$I_F =$	35	A
$V_{GE} =$	$\pm 15$	V

**Figure 15** D1,D2,D3,D4,D5,D6,D7 FWD

**Typical reverse recovery current as a function of collector current**

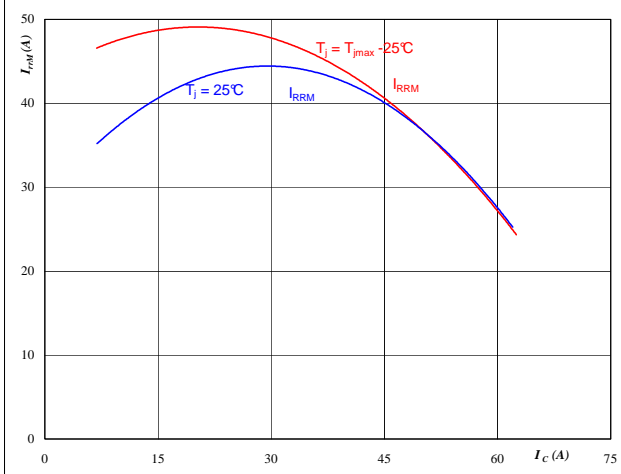
$I_{RRM} = f(I_C)$



**At**

$T_j =$	25/150	$^\circ\text{C}$
$V_{CE} =$	600	V
$V_{GE} =$	$\pm 15$	V
$R_{gon} =$	8	$\Omega$

**Figure 16** D1,D2,D3,D4,D5,D6,D7 FWD

**Typical reverse recovery current as a function of IGBT turn on gate resistor**

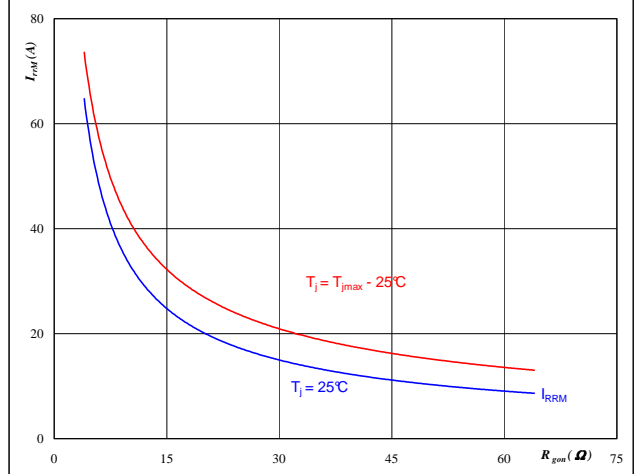
$I_{RRM} = f(R_{gon})$

**At**

$T_j =$	25/150	$^\circ\text{C}$
$V_R =$	600	V
$I_F =$	35	A
$V_{GE} =$	$\pm 15$	V

T1,T2,T3,T4,T5,T6,T7/D1,D2,D3,D4,D5,D6,D7

Figure 17 D1,D2,D3,D4,D5,D6,D7 FWD

Typical rate of fall of forward and reverse recovery current as a function of collector current

$dI_f/dt, dI_{rec}/dt = f(I_C)$

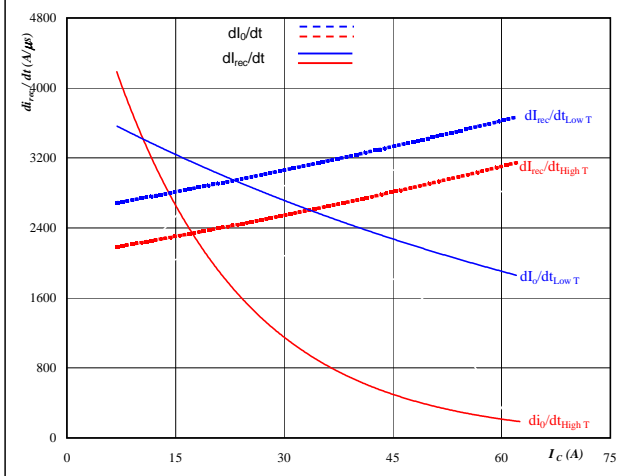

At  
 $T_j = 25/150 \text{ } ^\circ\text{C}$   
 $V_{CE} = 600 \text{ V}$   
 $V_{GE} = \pm 15 \text{ V}$   
 $R_{gon} = 8 \text{ } \Omega$

Figure 18 D1,D2,D3,D4,D5,D6,D7 FWD

Typical rate of fall of forward and reverse recovery current as a function of IGBT turn on gate resistor

$dI_f/dt, dI_{rec}/dt = f(R_{gon})$

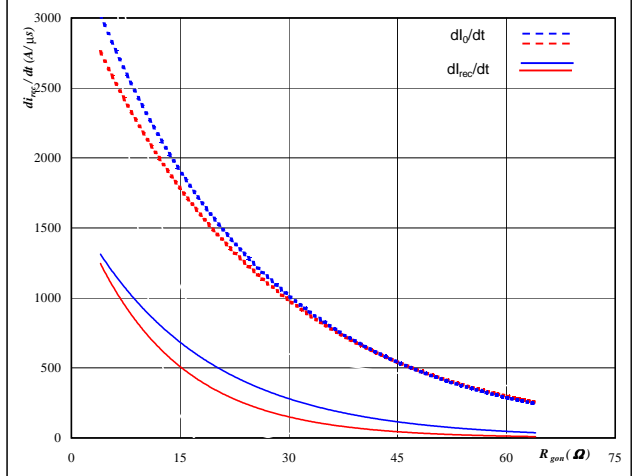

At  
 $T_j = 25/150 \text{ } ^\circ\text{C}$   
 $V_R = 600 \text{ V}$   
 $I_F = 35 \text{ A}$   
 $V_{GE} = \pm 15 \text{ V}$

Figure 19 T1,T2,T3,T4,T5,T6,T7 IGBT

IGBT transient thermal impedance as a function of pulse width

$Z_{thJH} = f(t_p)$

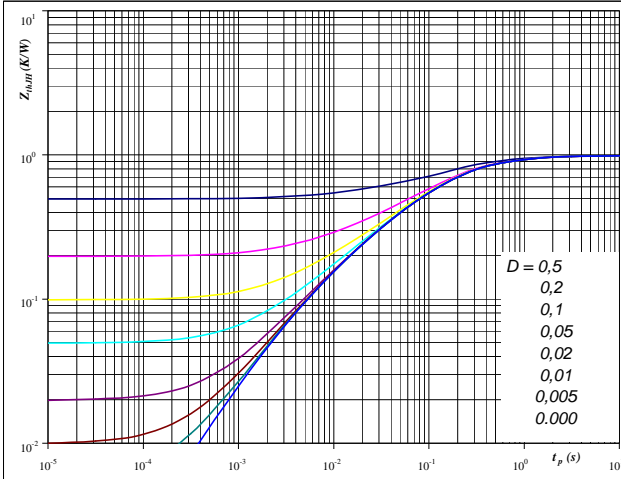

At  
 $D = t_p / T$   
 $R_{thJH} = 1 \text{ K/W}$

IGBT thermal model values

R (C/W)	Tau (s)
0,10	1,5E+00
0,31	2,7E-01
0,41	8,9E-02
0,13	1,4E-02
0,03	2,8E-03

Figure 20 D1,D2,D3,D4,D5,D6,D7 FWD

FWD transient thermal impedance as a function of pulse width

$Z_{thJH} = f(t_p)$

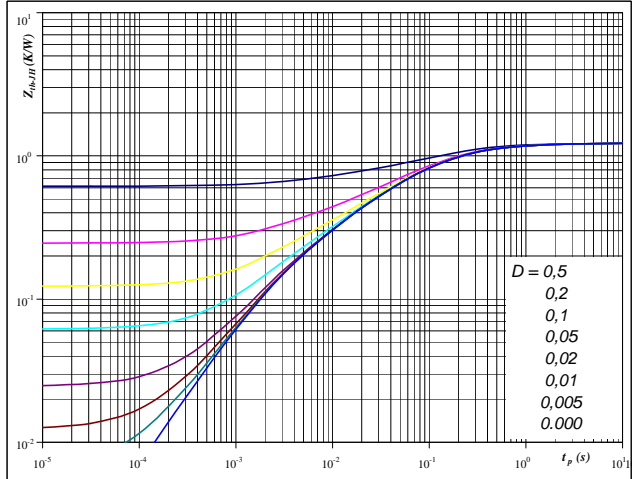

At  
 $D = t_p / T$   
 $R_{thJH} = 1,2 \text{ K/W}$

FWD thermal model values

R (C/W)	Tau (s)
0,08	2,1E+00
0,33	2,4E-01
0,50	6,6E-02
0,22	1,3E-02
0,10	2,3E-03



**T1,T2,T3,T4,T5,T6,T7/D1,D2,D3,D4,D5,D6,D7**
**Figure 21** T1,T2,T3,T4,T5,T6,T7 IGBT

**Power dissipation as a function of heatsink temperature**

$$P_{tot} = f(T_h)$$

**At**  
 $T_j = 175 \text{ } ^\circ\text{C}$ 
**Figure 22** T1,T2,T3,T4,T5,T6,T7 IGBT

**Collector current as a function of heatsink temperature**

$$I_C = f(T_h)$$

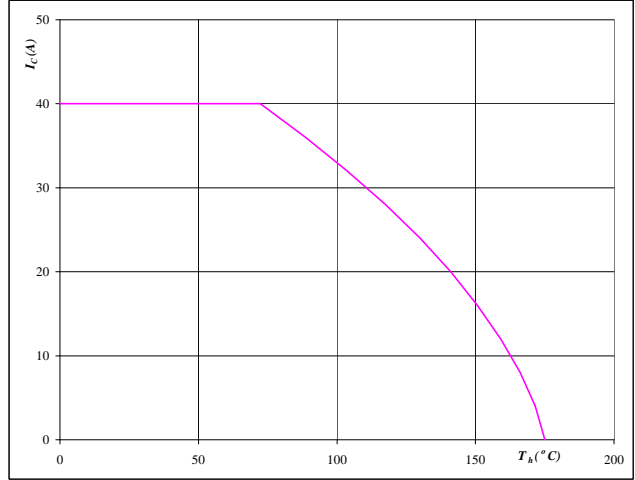
**At**  
 $T_j = 175 \text{ } ^\circ\text{C}$   
 $V_{GE} = 15 \text{ V}$ 
**Figure 23** D1,D2,D3,D4,D5,D6,D7 FWD

**Power dissipation as a function of heatsink temperature**

$$P_{tot} = f(T_h)$$

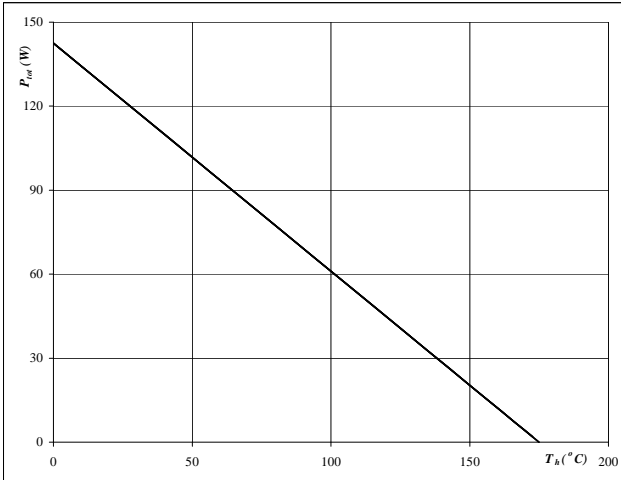
**At**  
 $T_j = 175 \text{ } ^\circ\text{C}$ 
**Figure 24** D1,D2,D3,D4,D5,D6,D7 FWD

**Forward current as a function of heatsink temperature**

$$I_F = f(T_h)$$

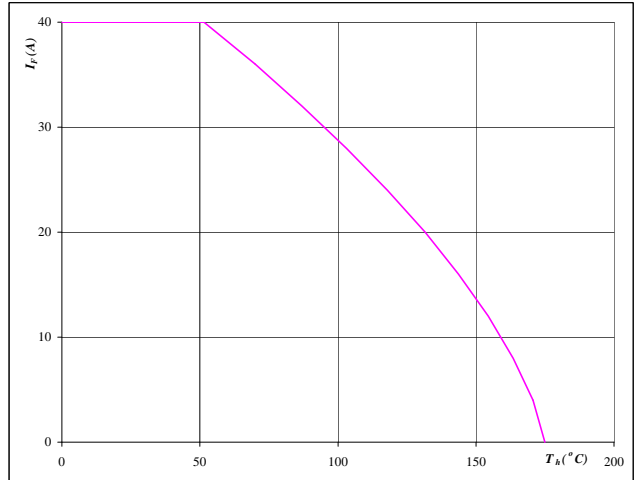
**At**  
 $T_j = 175 \text{ } ^\circ\text{C}$

**T1,T2,T3,T4,T5,T6,T7/D1,D2,D3,D4,D5,D6,D7**
**Figure 25** T1,T2,T3,T4,T5,T6,T7 IGBT

**Safe operating area as a function of collector-emitter voltage**

$I_C = f(V_{CE})$

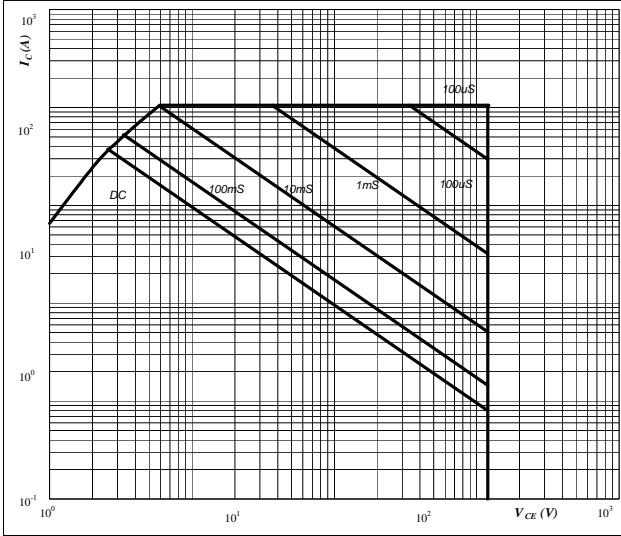

**At**  
 D = single pulse  
 $T_h = 80$  °C  
 $V_{GE} = \pm 15$  V  
 $T_j = T_{jmax}$  °C

**Figure 26** T1,T2,T3,T4,T5,T6,T7 IGBT

**Gate voltage vs Gate charge**

$V_{GE} = f(Q_{GE})$

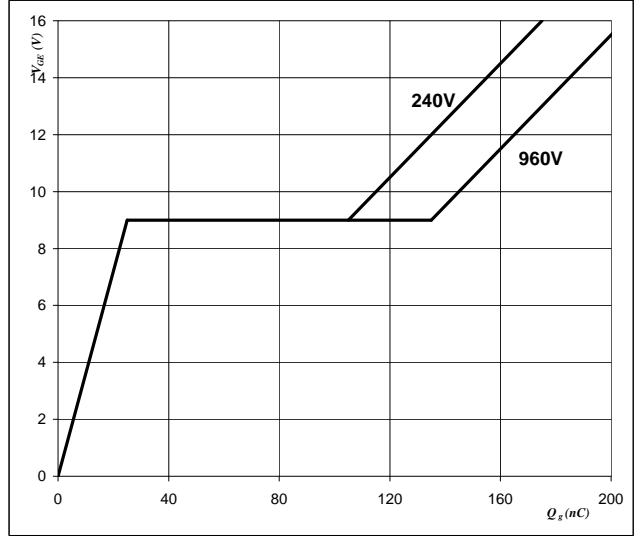

**At**  
 $I_C = 35$  A

D8,D9,D10,D11,D12,D13

Figure 1 D8,D9,D10,D11,D12,D13 diode

Typical diode forward current as a function of forward voltage

$I_F = f(V_F)$

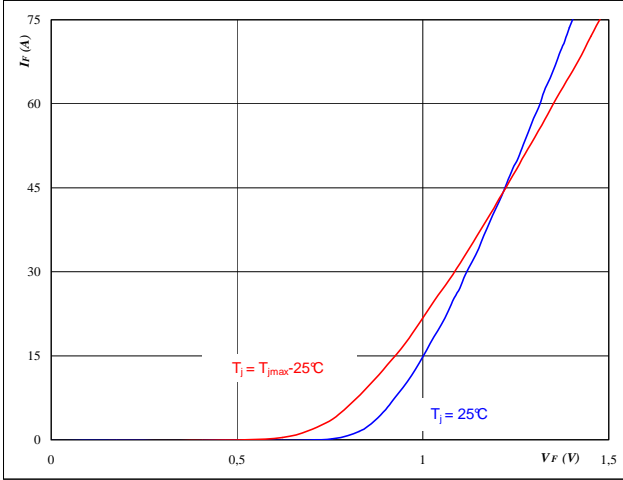

At  
 $t_p = 250 \mu s$

Figure 2 D8,D9,D10,D11,D12,D13 diode

Diode transient thermal impedance as a function of pulse width

$Z_{thJH} = f(t_p)$

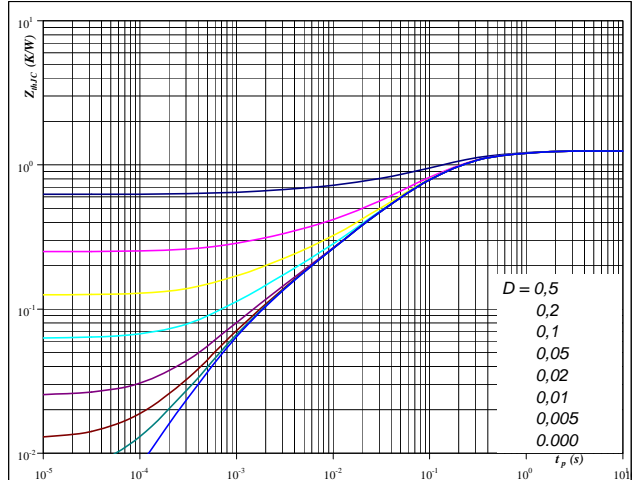

At  
 $D = t_p / T$   
 $R_{thJH} = 1,25 \text{ K/W}$

Figure 3 D8,D9,D10,D11,D12,D13 diode

Power dissipation as a function of heatsink temperature

$P_{tot} = f(T_h)$

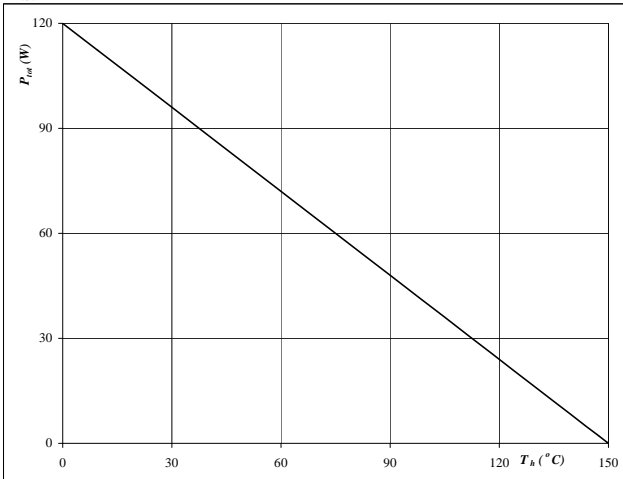

At  
 $T_j = 150 \text{ °C}$

Figure 4 D8,D9,D10,D11,D12,D13 diode

Forward current as a function of heatsink temperature

$I_F = f(T_h)$

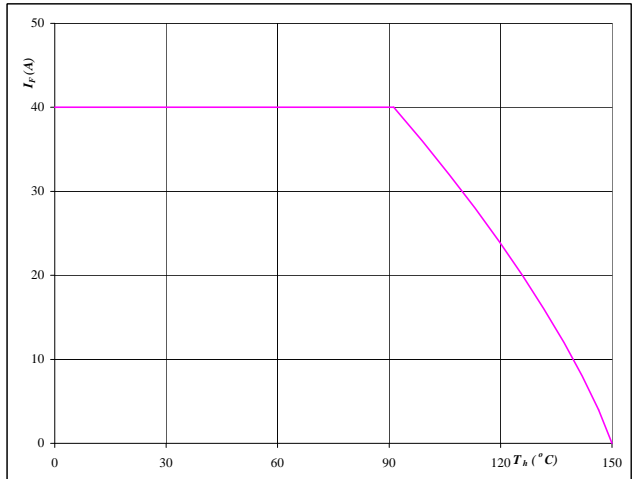

At  
 $T_j = 150 \text{ °C}$

## Thermistor

Figure 1 Thermistor

Typical PTC characteristic  
as a function of temperature

$$R_T = f(T)$$

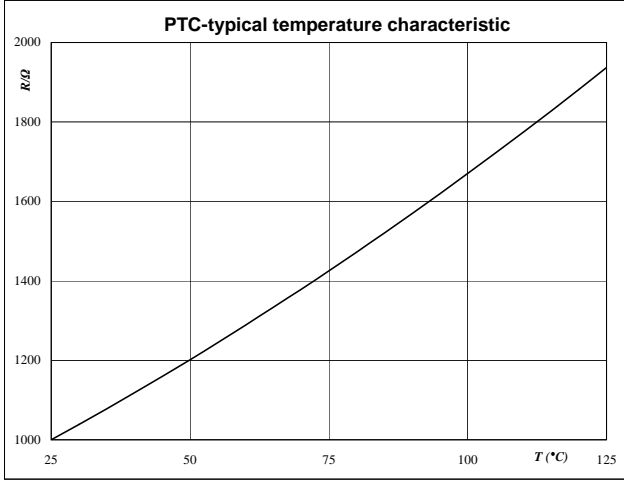

## Switching Definitions Output Inverter

General conditions	
$T_j$	= 150 °C
$R_{gon}$	= 16 $\Omega$
$R_{goff}$	= 16 $\Omega$

Figure 1 Output inverter IGBT

Turn-off Switching Waveforms & definition of  $t_{doff}$ ,  $t_{Eoff}$   
 ( $t_{Eoff}$  = integrating time for  $E_{off}$ )

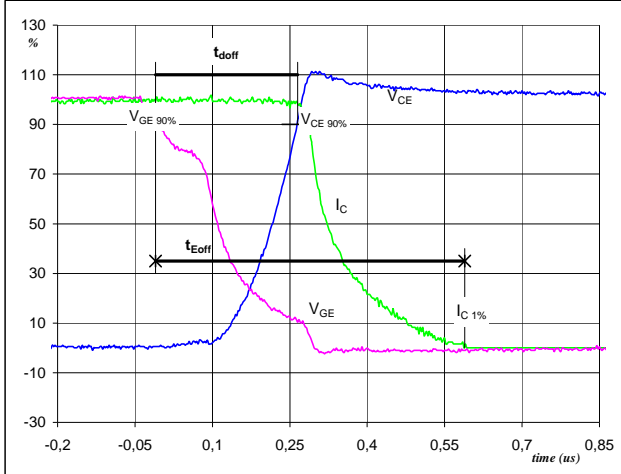

$V_{GE}(0\%) =$	-15	V
$V_{GE}(100\%) =$	15	V
$V_C(100\%) =$	600	V
$I_C(100\%) =$	35	A
$t_{doff} =$	0,27	$\mu$ s
$t_{Eoff} =$	0,60	$\mu$ s

Figure 2 Output inverter IGBT

Turn-on Switching Waveforms & definition of  $t_{don}$ ,  $t_{Eon}$   
 ( $t_{Eon}$  = integrating time for  $E_{on}$ )

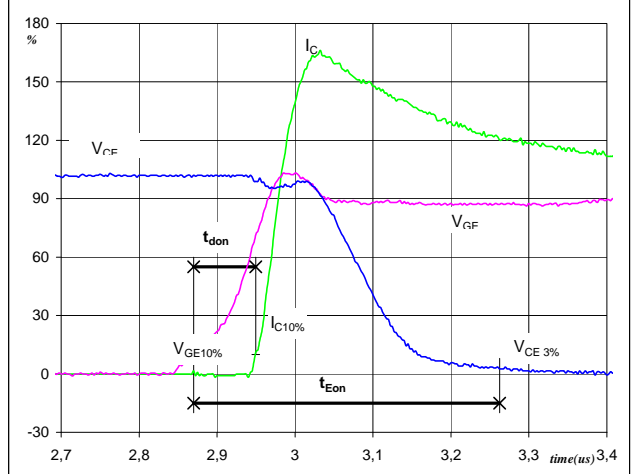

$V_{GE}(0\%) =$	-15	V
$V_{GE}(100\%) =$	15	V
$V_C(100\%) =$	600	V
$I_C(100\%) =$	35	A
$t_{don} =$	0,08	$\mu$ s
$t_{Eon} =$	0,39	$\mu$ s

Figure 3 Output inverter IGBT

Turn-off Switching Waveforms & definition of  $t_f$

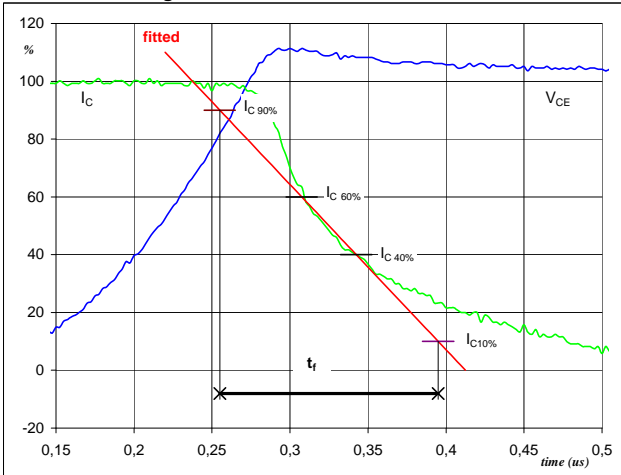

$V_C(100\%) =$	600	V
$I_C(100\%) =$	35	A
$t_f =$	0,13	$\mu$ s

Figure 4 Output inverter IGBT

Turn-on Switching Waveforms & definition of  $t_r$

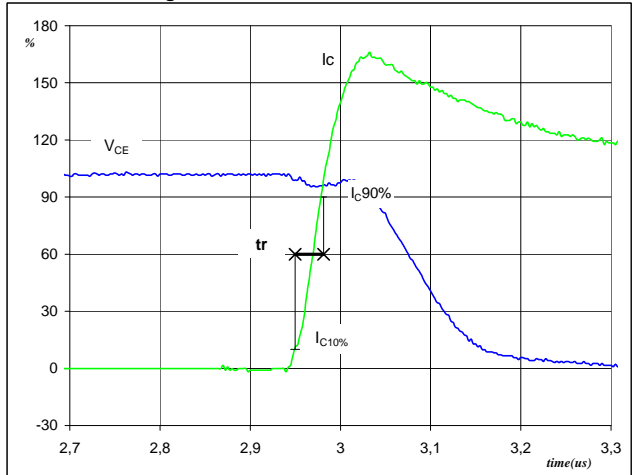

$V_C(100\%) =$	600	V
$I_C(100\%) =$	35	A
$t_r =$	0,03	$\mu$ s

## Switching Definitions Output Inverter

**Figure 5** Output inverter IGBT

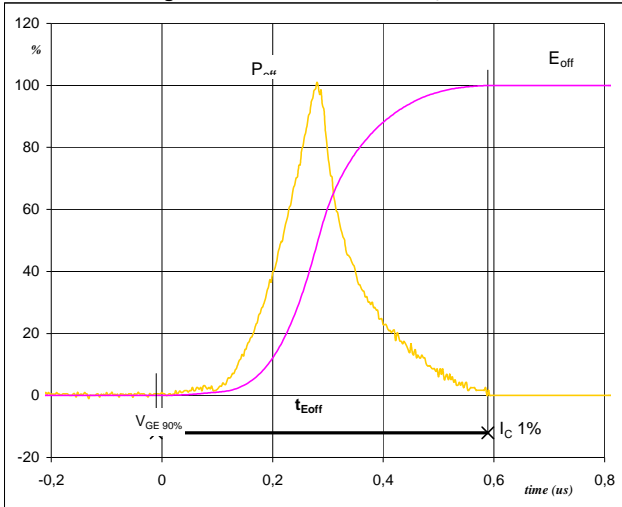
**Turn-off Switching Waveforms & definition of  $t_{Eoff}$** 

$P_{off}(100\%) = 20,88 \text{ kW}$   
 $E_{off}(100\%) = 3,18 \text{ mJ}$   
 $t_{Eoff} = 0,60 \text{ } \mu\text{s}$

**Figure 6** Output inverter IGBT

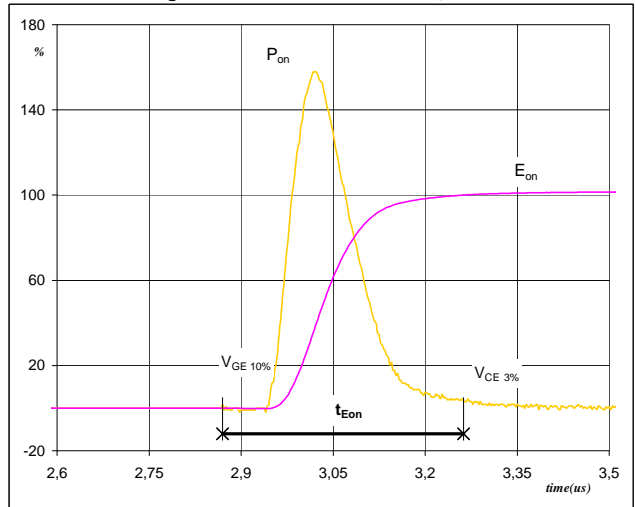
**Turn-on Switching Waveforms & definition of  $t_{Eon}$** 

$P_{on}(100\%) = 20,88 \text{ kW}$   
 $E_{on}(100\%) = 3,84 \text{ mJ}$   
 $t_{Eon} = 0,39 \text{ } \mu\text{s}$

**Figure 7** Output inverter FWD

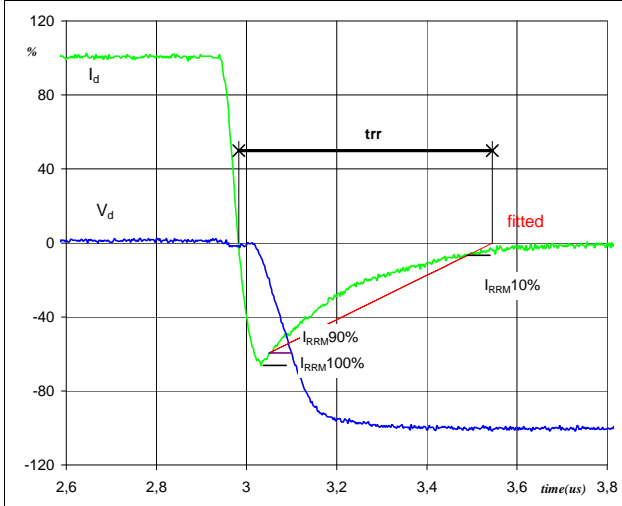
**Turn-off Switching Waveforms & definition of  $t_{tr}$** 

$V_d(100\%) = 600 \text{ V}$   
 $I_d(100\%) = 35 \text{ A}$   
 $I_{RRM}(100\%) = 23 \text{ A}$   
 $t_{tr} = 0,57 \text{ } \mu\text{s}$

## Switching Definitions Output Inverter

**Figure 8** Output inverter FWD

Turn-on Switching Waveforms & definition of  $t_{Qrr}$   
 ( $t_{Qrr}$  = integrating time for  $Q_{rr}$ )

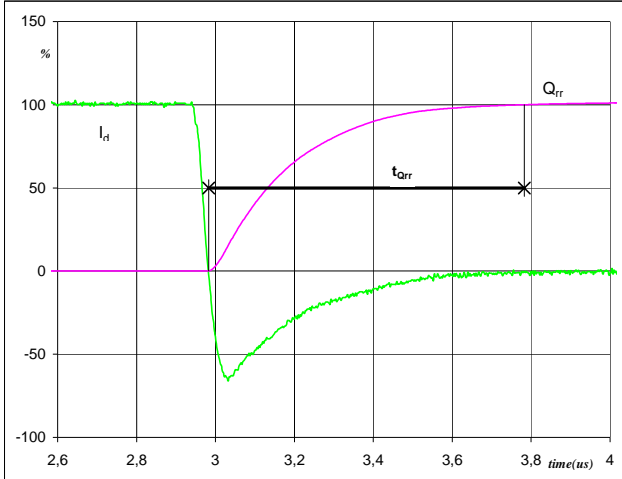

$I_d$ (100%) =	35	A
$Q_{rr}$ (100%) =	5,40	$\mu\text{C}$
$t_{Qrr}$ =	0,80	$\mu\text{s}$

**Figure 9** Output inverter FWD

Turn-on Switching Waveforms & definition of  $t_{Erec}$   
 ( $t_{Erec}$  = integrating time for  $E_{rec}$ )

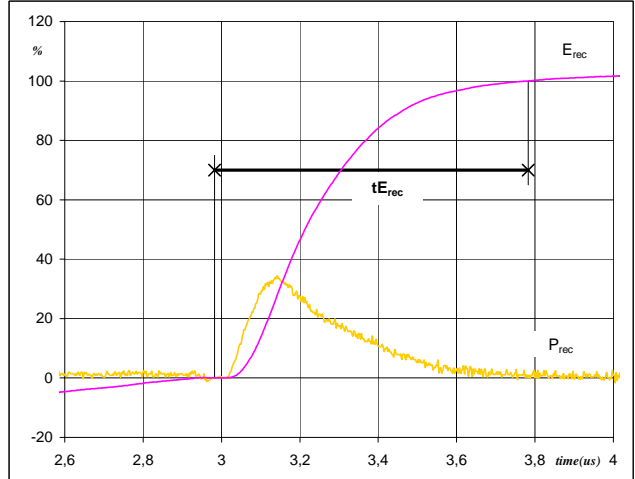

$P_{rec}$ (100%) =	20,88	kW
$E_{rec}$ (100%) =	2,10	mJ
$t_{Erec}$ =	0,80	$\mu\text{s}$

**Ordering Code and Marking - Outline - Pinout**
**Ordering Code & Marking**

Version	Ordering Code	in DataMatrix as	in packaging barcode as
with std lid (black V23990-K22-T-PM)	V23990-K220-A40-/0A/-PM	K220A40	K220A40-/0A/
with std lid (black V23990-K22-T-PM) and P12	V23990-K220-A40-/1A/-PM	K220A40	K220A40-/1A/
with thin lid (white V23990-K23-T-PM)	V23990-K220-A40-/0B/-PM	K220A40	K220A40-/0B/
with thin lid (white V23990-K23-T-PM) and P12	V23990-K220-A40-/1B/-PM	K220A40	K220A40-/1B/

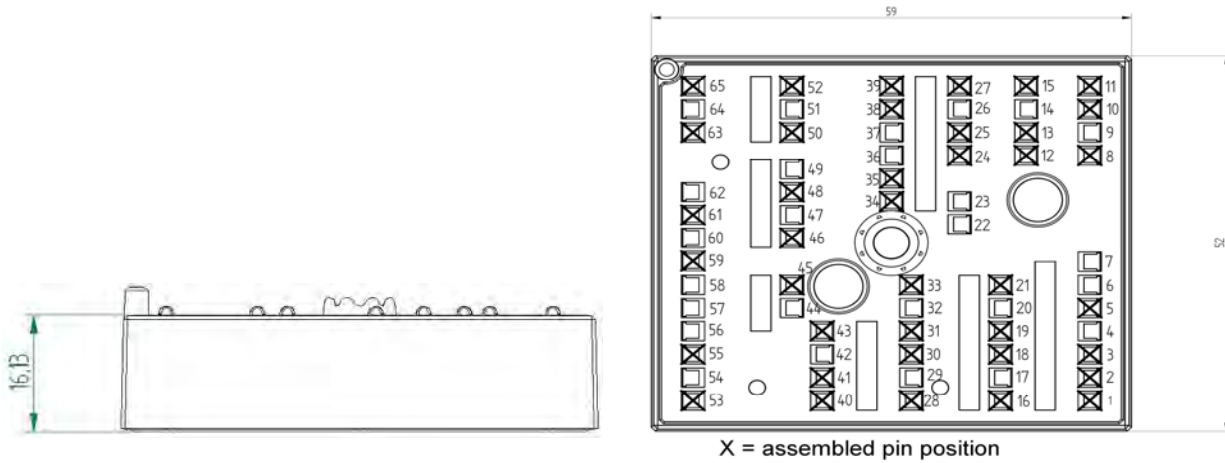
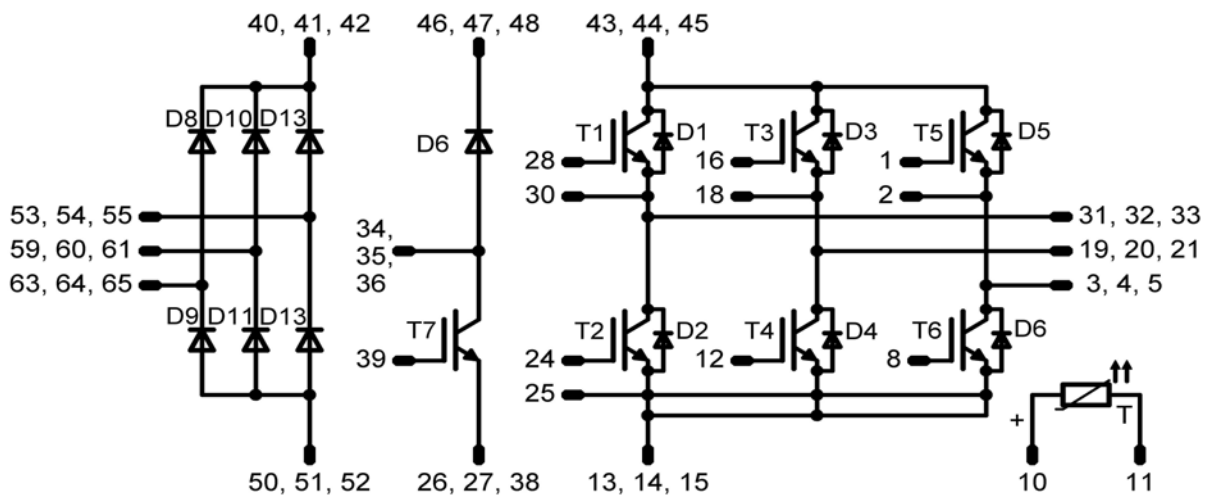
**Outline**

**Pinout**



**DISCLAIMER**

The information given in this datasheet describes the type of component and does not represent assured characteristics. For tested values please contact Vincotech. Vincotech reserves the right to make changes without further notice to any products herein to improve reliability, function or design. Vincotech does not assume any liability arising out of the application or use of any product or circuit described herein; neither does it convey any license under its patent rights, nor the rights of others.

**LIFE SUPPORT POLICY**

Vincotech products are not authorised for use as critical components in life support devices or systems without the express written approval of Vincotech.

As used herein:

1. Life support devices or systems are devices or systems which, (a) are intended for surgical implant into the body, or (b) support or sustain life, or (c) whose failure to perform when properly used in accordance with instructions for use provided in labelling can be reasonably expected to result in significant injury to the user.
2. A critical component is any component of a life support device or system whose failure to perform can be reasonably expected to cause the failure of the life support device or system, or to affect its safety or effectiveness.