

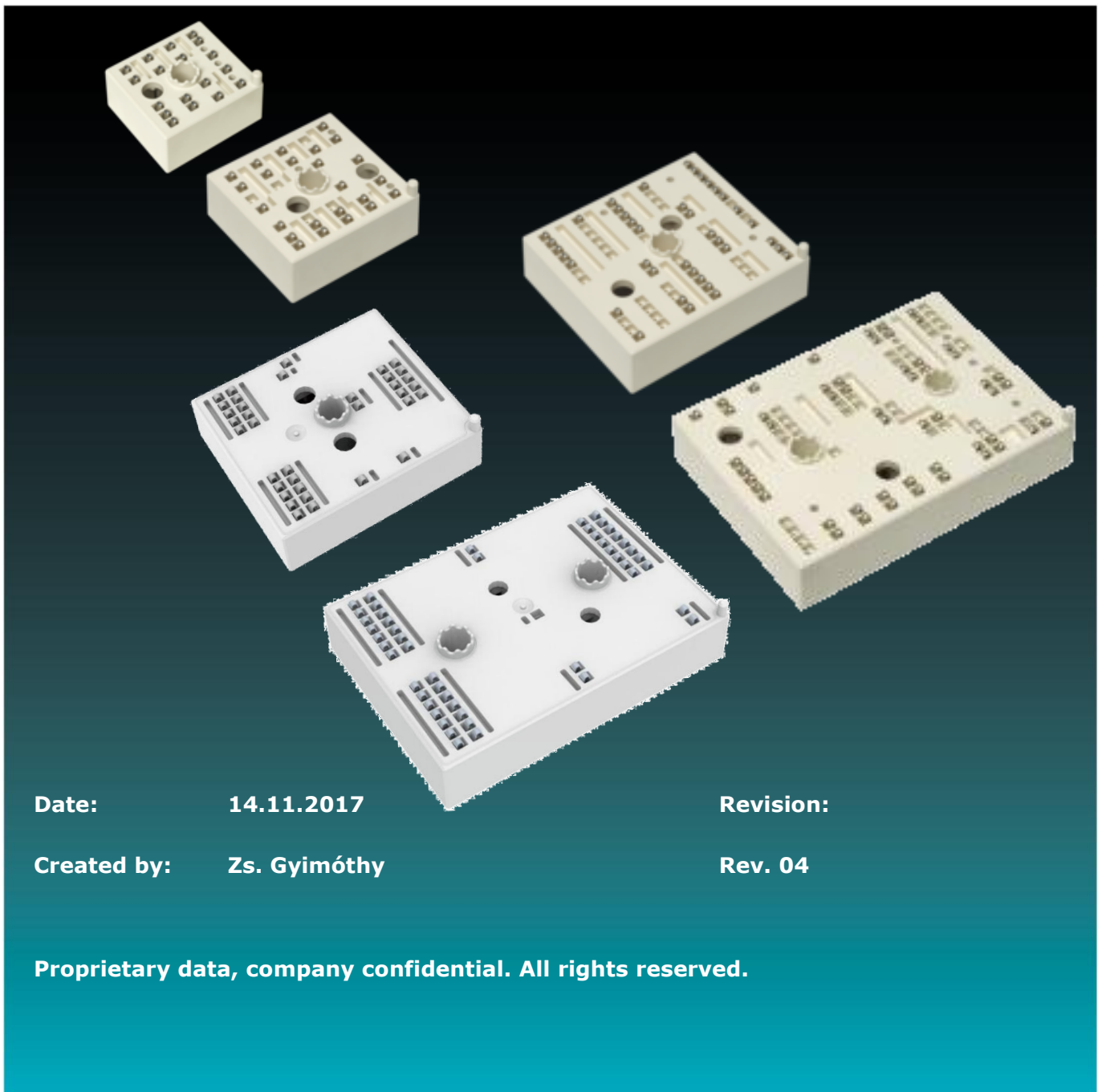

Vincotech

# Handling Instructions

for all MiniSKiiP® packages



**Date:** 14.11.2017

**Revision:**

**Created by:** Zs. Gyimóthy

**Rev. 04**

**Proprietary data, company confidential. All rights reserved.**



## Table of Contents

1	PCB specifications for the MiniSkiiP <sup>®</sup> contact system .....	5
2	Assembly .....	5
2.1	Preparations and surface specifications.....	5
2.1.1	Heat sink .....	5
2.1.2	Mounting surface .....	6
2.2	Spring contact specifications .....	8
2.2.1	Spring contact quality .....	8
2.3	Thermal interface material .....	9
2.3.1	Applying thermal paste.....	9
2.3.2	Pre-applied thermal paste.....	10
2.3.2.1	Silicone-based Standard Grease Wacker P12 .....	11
2.3.2.2	Silicone-free Standard Grease Thermigrease <sup>®</sup> TG20032 .....	12
2.3.2.3	High Performance Thermal Paste HPTP (silicone-based) .....	12
2.3.3	Deviations of the pre-applied paste pattern.....	13
2.4	Mounting .....	14
2.4.1	Mounting screw specifications .....	15
2.4.2	Using MiniSKiiP <sup>®</sup> module together with other Vincotech's standard module .....	15
2.4.3	Removing the MiniSKiiP <sup>®</sup> from the Heat Sink.....	15
3	Clearance and creepage distances .....	15
4	Storage and Shelf Life Conditions .....	17
5	ESD protection .....	17
6	Disclaimer .....	17



## Table of Figures

Figure 1: Heat sink surface specifications .....	5
Figure 2: DCB with fingerprints and discolorations .....	6
Figure 3: DCB's bottom surface after rework.....	6
Figure 4: Scratches on the MiniSKiiP®'s bottom surface.....	7
Figure 5: Etching hole (reaching down to the substrate) in a MiniSKiiP®'s bottom surface .....	7
Figure 6: Etching hole (shallower than the substrate) in a MiniSKiiP®'s bottom surface.....	7
Figure 7: Variance in the DCB's position .....	7
Figure 8: Spring overlay .....	8
Figure 9: Examples of discolored spring surface .....	8
Figure 10 continuous layer of thermal paste.....	9
Figure 11 paste pattern for MiniSKiiP® 0.....	10
Figure 12 paste pattern for MiniSKiiP® 1.....	10
Figure 13 paste pattern for MiniSKiiP® 2 and MiniSKiiP® DUAL 2.....	10
Figure 14 paste pattern for MiniSKiiP® 3 and MiniSKiiP® DUAL 3.....	11
Figure 15.....	13
Figure 16.....	13
Figure 17.....	13
Figure 18.....	13
Figure 19.....	13
Figure 20.....	13
Figure 21: Skin on thermal paste .....	14
Figure 22: MiniSKiiP® assembly cross-section indicating distances .....	16
Figure 23: Cross-section sketch with distance from pressure plate to PCB .....	16
Figure 24: Cross-section sketch with distance from screw to PCB .....	16



## Revision History

<b>Date</b>	<b>Revision Level</b>	<b>Description</b>	<b>Page Number(s)</b>
16.07.2015	01	Previous document: V23990-K-M118-04-31; New template; Change/extend Sections: 2.3	all; all; 9
08.03.2016	01.01	correction on tables of paste thickness; chapter 4	9-12, 13
06.10.2016	02	Section 2.2; 2.4.2; 2.4.3	8; 14
01.09.2017	03	extension for MiniSKiiP <sup>®</sup> DUALs; new TIM material HPTP – chapter 2.3.2.3	cover; 9-13
14.11.2017	04	new section for clearance/creepage distance: Section 3	15, 16



## 1 PCB specifications for the MiniSkiiP<sup>®</sup> contact system

The combination of surface materials where the MiniSkiiP<sup>®</sup> spring and the PCB landing pad meet affects the contact resistance for various currents. This is why the PCB has to be made with sufficiently thick plating. PCB surface coatings must also comply with RoHS regulations. The following finishes are recommended:

- Gold flash over nickel (NiAu)
- Hot air-leveled tin (HAL Sn)
- Chemical tin (Chem.I Sn)

Boards with OSP (organic solderability preservative) passivation are not recommended. OSP is unsuitable as there is no guarantee that the contact will remain free of corrosion over time. OSP passivation practically vanishes during soldering or after around six months in storage.

The data set needed to properly design PCBs are to be found at the Vincotech website. These package data documents contain drawings showing PCB size specifications, pin positions and lid specifications for all MiniSkiiP<sup>®</sup> housings.

## 2 Assembly

### 2.1 Preparations and surface specifications

The heat sink and module must meet the following requirements to achieve maximum thermal conductivity.

#### 2.1.1 Heat sink

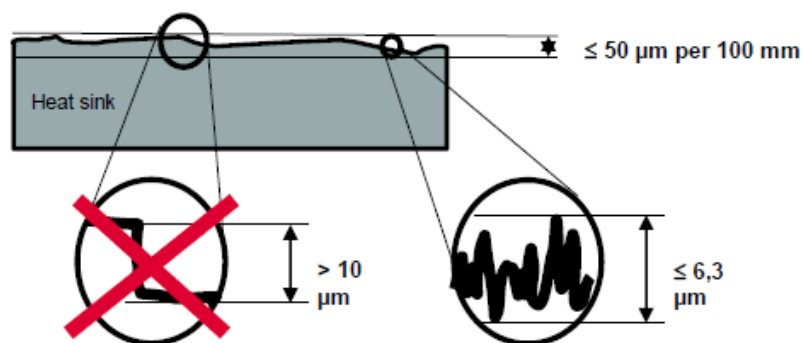

Figure 1: Heat sink surface specifications

- The heat sink must be free of grease and particles.
- The heat sink's mounting surface irregularity has to be  $\leq 50 \mu\text{m}$  per 100 mm (DIN EN ISO 1101).
- $RZ \leq 6.3 \mu\text{m}$  (DIN EN ISO 4287)
- No steps  $> 10 \mu\text{m}$  (DIN EN ISO 4287)



### 2.1.2 Mounting surface

The MiniSKiiP<sup>®</sup> module's mounting surface also has to be free of grease and any foreign particles. MiniSKiiP<sup>®</sup> modules are made using DBC without finishing or with a gold-flash finish (NiAu). Fingerprints or discolorations (Fig. 2) on the bottom of the DBC have no impact on thermal behavior and are therefore not failure criteria.

Rework or a second cleaning operation could leave imperfections in the gold-flash finish on the bottom of the DBC. Such an imperfection in the gold-flash finish does not affect thermal behavior (Fig. 3). The gold-flash finish is necessary only on the DBC's top side to serve as the spring landing pad. It is far more costly to plate a single side, so the bottom is only coated as a by-product of the plating process.

The bottom of the MiniSKiiP<sup>®</sup> module may exhibit scratches, holes or similar marks incurred during manufacturing. The pictures below show surface marks that do not affect thermal behavior. Failures can occur in the event of deformations exceeding the tolerances specified below.

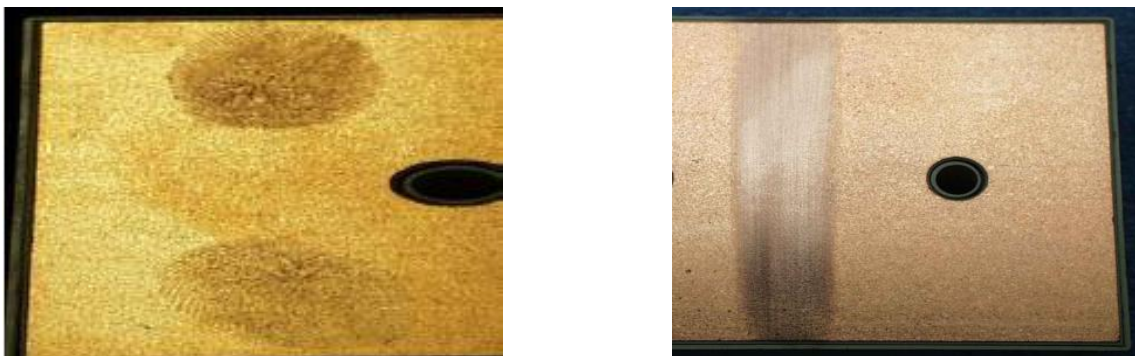

Figure 2: DCB with fingerprints and discolorations



Figure 3: DCB's bottom surface after rework

MiniSKiiP<sup>®</sup> modules must always comply with the specifications indicated from Figure 4 to Figure 6.

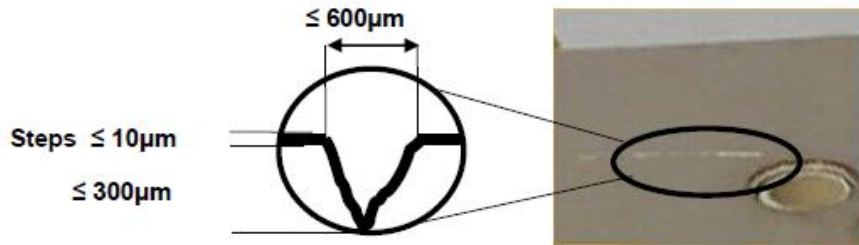

Figure 4: Scratches on the MiniSKiiP's bottom surface

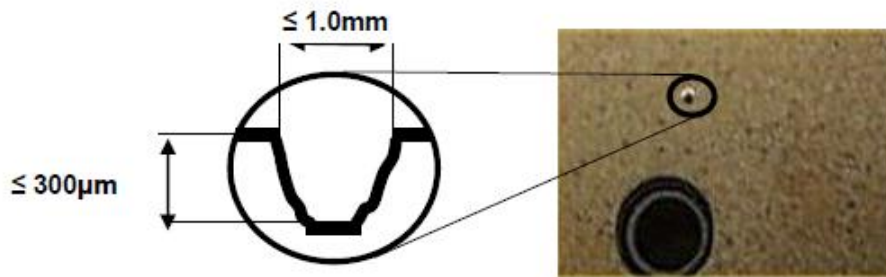

Figure 5: Etching hole (reaching down to the substrate) in a MiniSKiiP's bottom surface

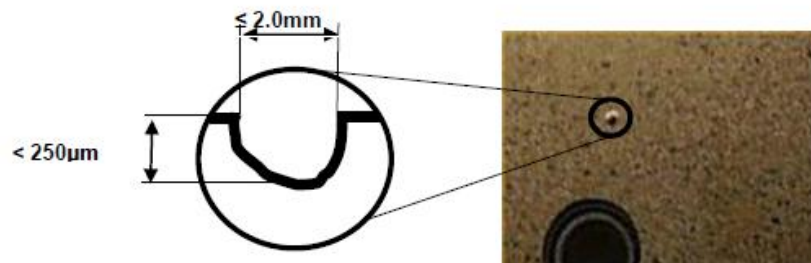

Figure 6: Etching hole (shallower than the substrate) in a MiniSKiiP's bottom surface

Etched dimples on the edge of the DBC reduce stress between the copper layer and the ceramic substrate. Dimples are usually around  $\varnothing \approx 0.6$  mm in diameter and around 0.3 mm in depth. They are never located below an IGBT or Diode chip and therefore do not affect thermal behavior. There may be some manufacturing-related variance in the substrate's position within the plastic housing. The gap between the housing and substrate may be no greater than 0.55 mm (Figure 7).

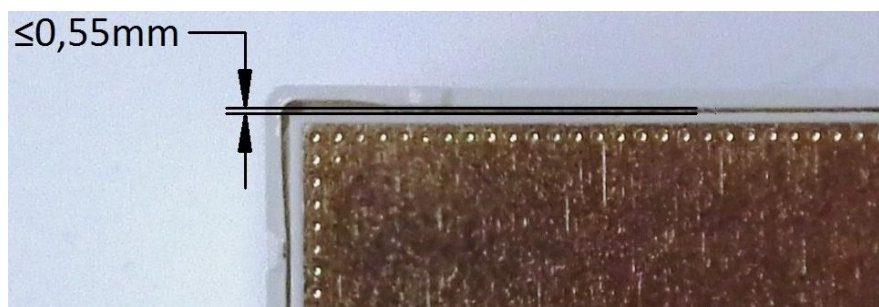

Figure 7: Variance in the DCB's position



## 2.2 Spring contact specifications

- The spring must protrude from the housing no less than 0.9 mm (Figure 8), measured from the top surface to the head of the spring, to ensure a proper contact after mounting.
- The spring's base material is a high-performance copper alloy. The spring is not expected to fatigue over the MiniSKiiP<sup>®</sup>'s lifetime.
- To function properly, spring contacts may not be contaminated by oil, sweat or other substances.
- The spring surface is never to be touched with bare fingers! It is advisable to wear gloves when handling MiniSKiiP<sup>®</sup> modules. Do not apply contact spray or other chemicals to the springs!

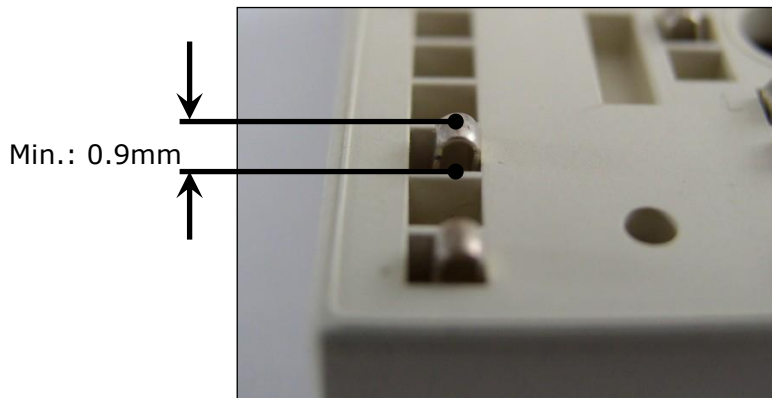

Figure 8: Spring overlay

### 2.2.1 Spring contact quality

The silver surface of spring pins in MiniSKiiP<sup>®</sup> modules is covered with a silver passivation film to protect it from deterioration. It is merely cosmetic, protecting the silver surface from sulfuration and tarnishing for around half a year.

The silver springs may begin to decolorize after that depending on the tarnish protection's thickness. Different springs on the same module may exhibit different levels of discoloration as shown in the examples in Figure 9.

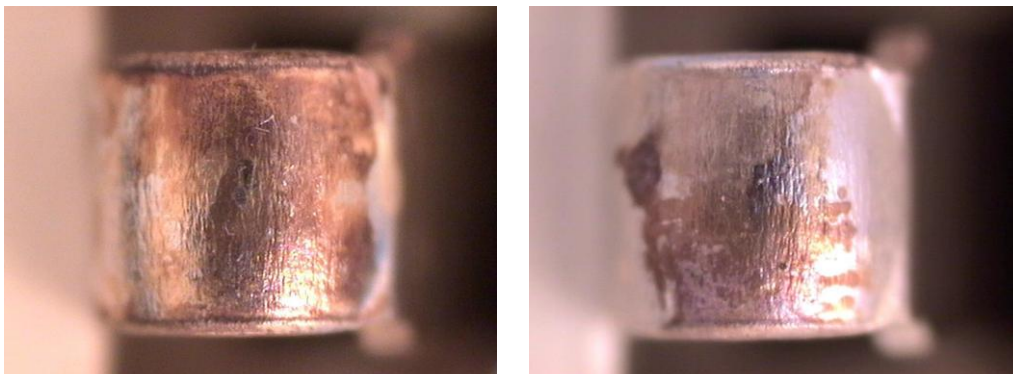

Figure 9: Examples of discolored spring surface

The yellow marks shown above are caused by thin sulphide layers that are easily pierced during mounting and do not impair the electrical contact.





## 2.3 Thermal interface material

### 2.3.1 Applying thermal paste

Apply a thin layer of thermal paste to the heat sink or the module's bottom surface. VINCOTECH recommends for it to be screen-printed because this method of application is reproducible and achieves a uniform layer. Paste may also be applied using a hard rubber roller, but this has to be done with painstaking care to achieve acceptable results. The thickness of the thermal paste layer should be measured and confirmed. The table below shows the recommended thicknesses for the following thermal paste:

#### **Silicone-based Standard Grease Wacker P 12** made by WACKER CHEMIE

Paste thickness ranges for continuous layer

	min.	max.
MiniSKiip <sup>®</sup> 0:	16 µm	28 µm
MiniSKiip <sup>®</sup> 1:	21 µm	38 µm
MiniSKiip <sup>®</sup> 2 / MiniSKiip <sup>®</sup> DUAL 2	38 µm	60 µm
MiniSKiip <sup>®</sup> 3 / MiniSKiip <sup>®</sup> DUAL 3	27 µm	43 µm

These specifications apply to a continuous film of thermal paste. If the application tool leaves a pattern as is the case with printing, the thickness has to be adjusted so that the resultant continuous layer of thermal paste is within values specified above.



Figure 10 continuous layer of thermal paste



### 2.3.2 Pre-applied thermal paste

VINCOTECH offers the MiniSKiiP<sup>®</sup> module with pre-applied thermal paste in special *honeycomb pattern* to facilitate assembly. Thermal paste is applied before the modules ship, thereby eliminating this critical step from the customer's manufacturing process and making assembly more efficient, reproducible and controllable. An automated and monitored screen printer applies thermal paste to the module in a layer with precisely the right thickness.

The following pictures (Figure 11–14) show the pre-applied paste in honeycomb pattern for each MiniSKiiP<sup>®</sup> types:

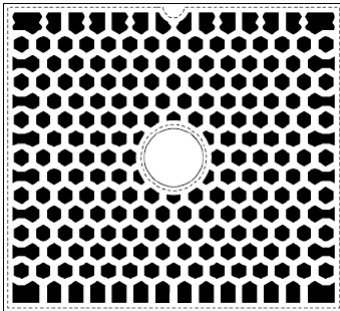

Figure 11 paste pattern for MiniSKiiP<sup>®</sup> 0

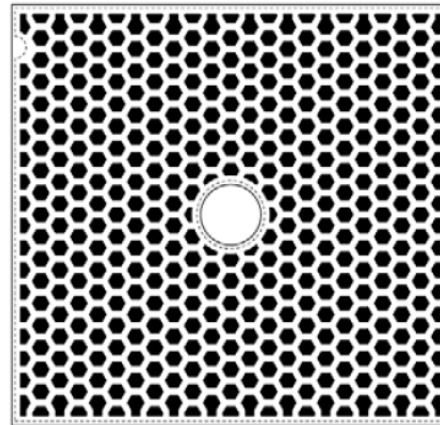

Figure 12 paste pattern for MiniSKiiP<sup>®</sup> 1

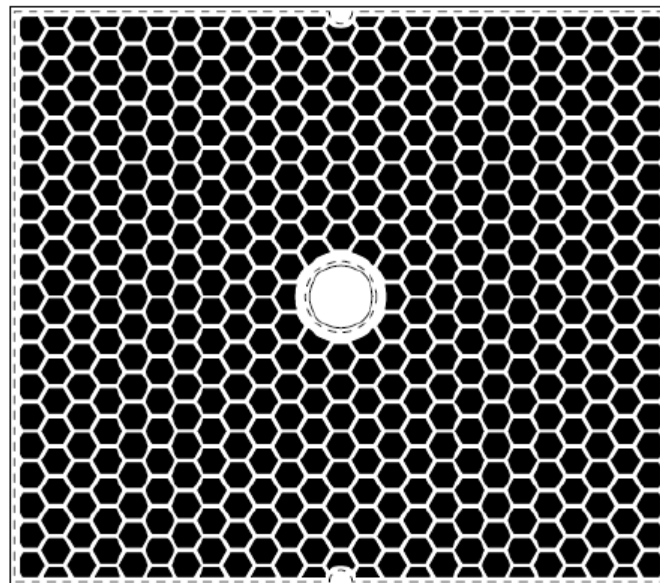

Figure 13 paste pattern for MiniSKiiP<sup>®</sup> 2 and MiniSKiiP<sup>®</sup> DUAL 2

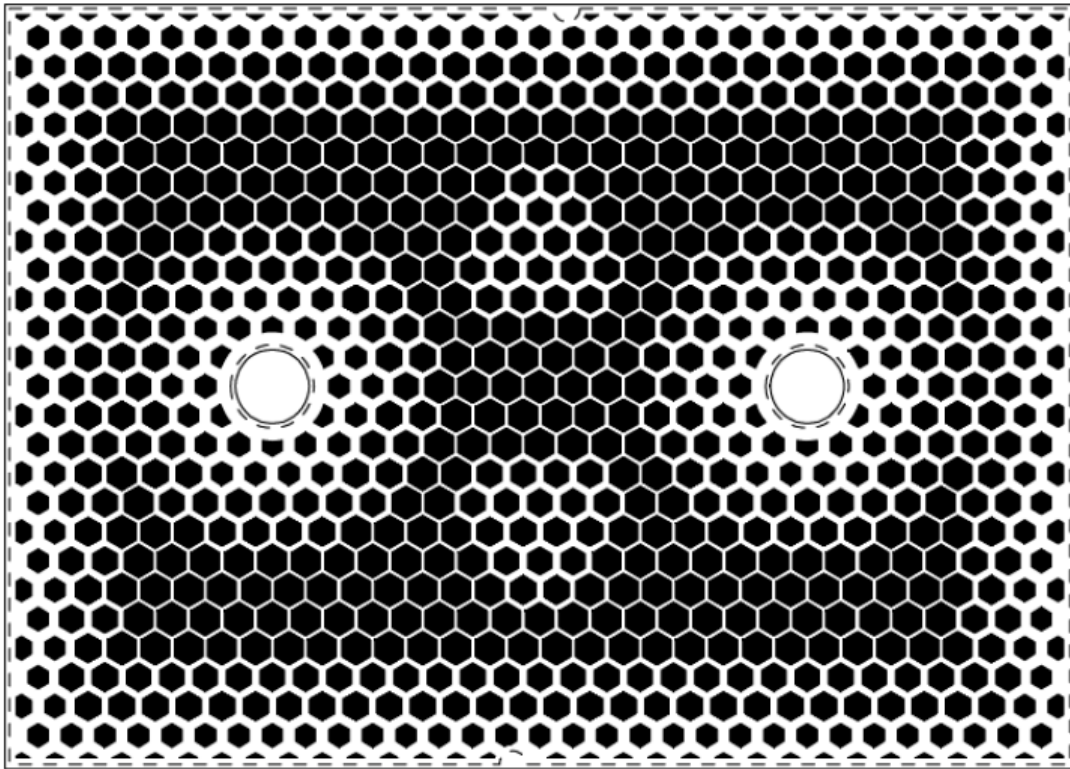

Figure 14 paste pattern for MiniSKiip® 3 and MiniSKiip® DUAL 3

### 2.3.2.1 Silicone-based Standard Grease Wacker P12

Paste thickness ranges for *honeycomb* layer

	min.	max.
MiniSKiip® 0:	40 µm	70 µm
MiniSKiip® 1:	50 µm	90 µm
MiniSKiip® 2 / MiniSKiip® DUAL 2	60 µm	90 µm
MiniSKiip® 3 / MiniSKiip® DUAL 3	50 µm	80 µm

Ordering code:

-/1A/-

-/1B/-

- 1 indicates the applied thermal paste.
- A indicates a standard 6.5 mm thick lid.
- B indicates a thin 2.8 mm thick lid.



Example order:

V23990-K420-A60-/1A/-PM

The product will be delivered with thermal paste and a 6.5 mm thick lid.

### 2.3.2.2 Silicone-free Standard Grease Thermigrease® TG20032

Paste thickness ranges for *honeycomb* layer

	min.	max.
MiniSKiip® 0:	45 µm	80 µm
MiniSKiip® 1:	55 µm	90 µm
MiniSKiip® 2 / MiniSKiip® DUAL 2	65 µm	95 µm
MiniSKiip® 3 / MiniSKiip® DUAL 3	50 µm	85 µm

Ordering code:

-/4A/-

-/4B/-

4 indicates the applied thermal paste.

A indicates a standard 6.5 mm thick lid.

B indicates a thin 2.8 mm thick lid.

Example order:

V23990-K420-A60-/4B/-PM

The product will be delivered with thermal paste and a 2.8 mm thick lid.

### 2.3.2.3 High Performance Thermal Paste HPTP (silicone-based)

Paste thickness ranges for *honeycomb* layer

	min.	max.
MiniSKiip® 1:	80 µm	130 µm
MiniSKiip® 2:	70 µm	130 µm
MiniSKiip® 3:	70 µm	130 µm



Ordering code:

-/5A/-

-/5B/-

5 indicates the applied thermal paste.

A indicates a standard 6.5 mm thick lid.

B indicates a thin 2.8 mm thick lid.

Example order:

V23990-K420-A60-/5B/-PM

The product will be delivered with thermal paste and a 2.8 mm thick lid.

### 2.3.3 Deviations of the pre-applied paste pattern

The following slight deviations may occur because of the automated screen-printing process. They have no effect on the mounting process or thermal properties.

- Slight variations in print positioning
- Slight variances in the thermal paste's pattern (Figure 155-Figure 199)
- Slight subsurface migration (Figure 20)

The honeycomb pattern may vary by no more than 5% in size.



Figure 15



Figure 16



Figure 17

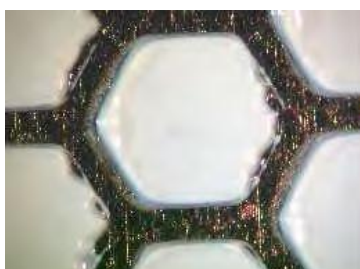

Figure 18



Figure 19

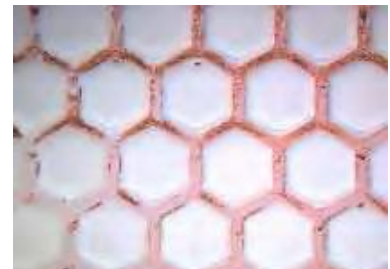

Figure 20

If the modules are stored or transported (see also section 3, Storage and Shelf Life Conditions) at temperatures  $<60^{\circ}\text{C}$  and at high humidity  $>85\%$ , a thin skin may form on the surface of the thermal paste layer (Figure 20). This has no effect on the module's thermal properties or the thermal grease's function.



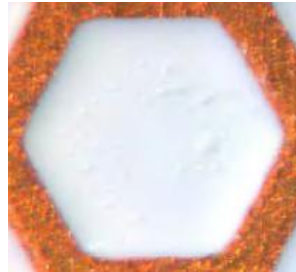

Figure 21: Skin on thermal paste

## 2.4 Mounting

- For MiniSKiiP<sup>®</sup> 0, 1 and 2 place the module on the heat sink's target area, place PCB down on the module - visually confirm the corner pin comes through the PCB hole -, place the pressure lid - make sure the corner pin aligns properly into the pressure lid -, and insert / tighten the screw with a nominal torque of  $2.0 \text{ Nm} < M < 2.5 \text{ Nm}$ .
- For MiniSKiiP<sup>®</sup> 3 modules with two screws the mounting steps are the same, except tightening the screws: first fasten both screws with a torque no higher than 1 Nm and then tighten them with the nominal torque of  $2.0 \text{ Nm} < M < 2.5 \text{ Nm}$ .
- An electrical power screwdriver is preferable to a pneumatic tool. Torque and RPM may be controlled far more accurately with electrically powered tools and they reach the target torque much more smoothly. The action of a pneumatic tool's clutch can produce a mechanical shock and overshoot the target torque, both of which could damage the module.
- Fasten mounting screws at a speed slow enough to allow thermal paste to flow and be distributed uniformly, especially when using denser pastes. If screws are tightened at faster speeds, the ceramic may crack because the paste is unable to flow as fast as necessary, leaving an irregular surface. The specifications given below apply to Wacker P12 thermal paste and electrical power screwdrivers.
- Limit the rotational speed to no greater than 250 rpm when fastening screws. It is also advisable to gently decelerate, thereby preventing torque overshoot and reducing the stress on components.
- Loosening torque is lower because of the housing and thermal paste's elasticity. 0.6 Nm is sufficient to achieve a proper thermal contact. The housing's design, the elastic give of the metal plate in the pressure lid, and the thermal paste's adhesive properties ensure an electrical contact is made and sufficient thermal coupling is achieved between the module and heat sink.
- **Caution: Do not retighten screws to the nominal mounting torque!** This will place undue stress on the DBC, housing and springs.
- The pressure lid and PCB may be removed from the MiniSKiiP<sup>®</sup> module for rework or testing and then remounted or replaced. If a module is incorrectly aligned with the heat sink, it may be removed and then placed in the proper position, but only if it has not already been fastened to the heat sink with a screw. The thermal paste is quite adhesive, so this will require some painstaking effort. Subsequently, all thermal paste has to be carefully removed from the module and heat sink. Alcohol may be used to clean the surfaces.
- The pressure will drop somewhat over time in an assembled MiniSKiiP<sup>®</sup> because of the give of its components. Although a MiniSKiiP<sup>®</sup> may be re-assembled, the pressure could be distributed differently than in a new module and its thermal resistance may differ from the values given in the data sheet.



## 2.4.1 Mounting screw specifications

Recommended mounting screw:

- M4 according to DIN 7991 - 8.8 or a similar screw with a TORX head
- Screw class: 8.8
- Tensile strength:  $R_m = 800 \text{ N/mm}^2$
- Yield point:  $R_e = 640 \text{ N/mm}^2$
- The minimum depth of the screw in the heat sink is 6.0 mm

## 2.4.2 Using MiniSKiiP<sup>®</sup> module together with other Vincotech's standard module

MiniSKiiP<sup>®</sup> modules together with other Vincotech's standard product can not be mounted onto the same PCB - and heat sink level.

## 2.4.3 Removing the MiniSKiiP<sup>®</sup> from the Heat Sink

The thermal paste provides good adhesion between the module and the heat sink. Since the DBC substrates with the chips are not glued to the case, these would stick to the heat sink when the module was removed as soon as the screws are loosened.

There are two proper ways for removing the module:

- Wait 24 hours after the screws have been loosened and then slide the module carefully from the heat sink.
- Heat up the heat sink up to 60 °C after the screws have been loosened and then slide the module carefully from the heat sink.

## 3 Clearance and creepage distances

The pressure lid of MiniSKiiP<sup>®</sup> is designed as a hybrid construction with a metal inlay. The mounting screw is electrically connected with the metal inlay and the heat sink. Since the pressure lid has the same electrical potential as the heat sink creepage and clearance distance considerations are required. Due to the design, clearance and creepage distances are the same.

The distance between the metal inlay of the lid and the printed circuit board (Figure 22, 1.) are  $> 8.6 \text{ mm}$  as given in Figure 23. The internal distance between screw and board (Figure 22, 2.) is  $> 6.3 \text{ mm}$ , as given in Figure 24.

Inside the MiniSKiiP<sup>®</sup> a transparent silicone gel ensures the electrical isolation from the DCB substrate to the heat sink (Figure 22, 3.) as well as from the DCB to the screw (Figure 22, 4.).



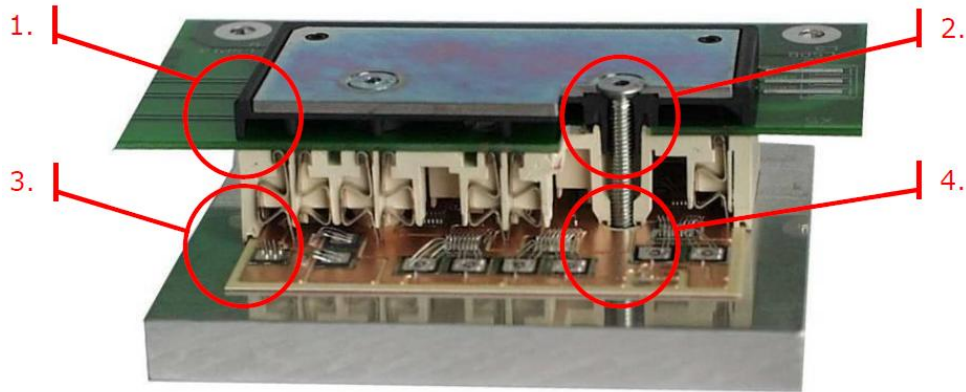

Figure 22: MiniSKiiP® assembly cross-section indicating distances

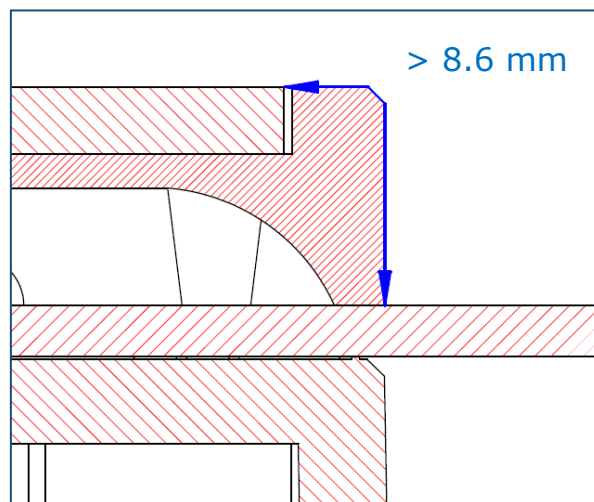

Figure 23: Cross-section sketch with distance from pressure plate to PCB

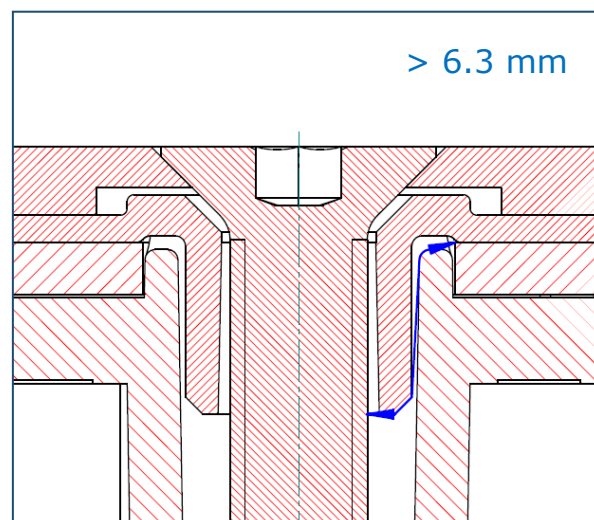

Figure 24: Cross-section sketch with distance from screw to PCB



## 4 Storage and Shelf Life Conditions

MiniSKiiP power modules are qualified to IEC 60721-4-1 and may be stored in the original package for two years under climatic class 1K2 (IEC 60721-3-1):

Relative humidity: 5%...85%  
Storage temperature: 5°C...40°C

Although the following shelf life conditions have not been tested, they are advisable and experience has shown that they should not be exceeded or disregarded:

Relative humidity: 85% max.  
Storage temperature: -25°C...+60°C  
Condensation: none  
Storage time: 2 years max.

The reverse current limits may be exceeded after extreme humidity, but this does not adversely affect the performance of the MiniSKiiP<sup>®</sup>.

## 5 ESD protection

Modules are sensitive to electrostatic discharge which can damage or destroy sensitive semiconductors. All modules are ESD protected in the shipment box by semi conductive plastic trays. During the handling and assembly of the modules it is required to wear a conductive grounded wrist band and ensure a conductive grounded working place.

Please take into consideration the following standards for handling electrostatic-sensitive devices: IEC 61340-5-1, ANSI/ESD S20.20

## 6 Disclaimer

The information given in this document should not be used in substitution for the customer's tests because the conditions and circumstances of the application are beyond Vincotech's control. The content of this document is true and accurate to the best of our knowledge, reflects current standards, and has been compiled with due care.

*MiniSKiiP<sup>®</sup> is a trademark of SEMIKRON Elektronik GmbH & Co. KG*