

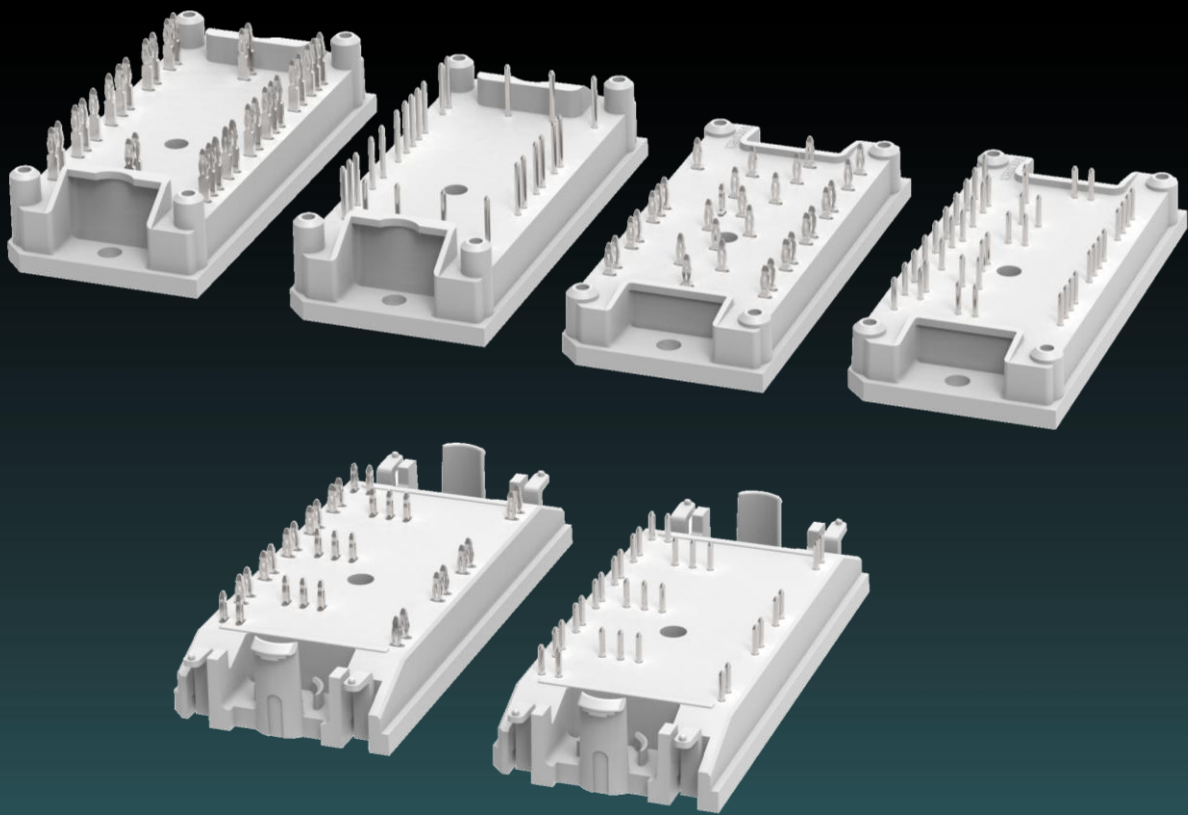

Vincotech

# Handling Instructions

for *flow 1* packages



*This document is valid for all type of flow 1 modules:  
12 mm & 17 mm housing, clips & tower versions, solder & Press-fit  
pins*

**Date:** 09.02.2016

**Revision:**

**Created by:** Zs. Gyimóthy

**Rev. 05**

**Proprietary data, company confidential. All rights reserved.**



## Table of Contents

1	General assembly instructions.....	6
2	Specification for PCBs .....	7
2.1	Specification for modules with Press-fit pins .....	7
2.2	Specification for modules with solder pins .....	8
2.3	Specification for modules with Press-fit pins that are soldered to the PCB .....	8
2.4	Required PCB cutouts for module with clips .....	9
2.4.1	For modules with 2-clips and solder pins .....	9
2.4.2	For modules with 2-clips and Press-fit pins .....	10
3	Specification for module backside surface .....	11
4	Specification for heat sink .....	12
5	Specification for thermal interface materials .....	13
5.1	OPTION 1: Thermal paste: .....	13
5.2	OPTION 2: Thermal foil: .....	13
5.3	OPTION 3: Pre-applied thermal interface material .....	14
6	Specification for fastening screws to the heat sink .....	15
6.1	Screw with pre-assembled washers.....	15
6.2	Mounting with automatic screwdriver .....	16
7	Mounting options of modules with Press-fit pins .....	17
8	Press-in process of modules with Press-fit pins .....	17
8.1	Press-in construction .....	17
8.1.1	Press-in tool .....	18
8.1.1.1	Modules without thermal interface material .....	18
8.1.1.2	Modules with thermal interface material .....	19
8.1.2	Supporting tool .....	20
8.2	Press-in process parameters .....	21
8.2.1	Basic requirements for the press-in process.....	22
8.3	Process control parameters .....	22
9	Press-out process for modules with Press-fit pins .....	24
9.1	Press out tool.....	25
9.2	Press-out process characteristics .....	26
9.2.1	Press-out process parameters .....	27
9.3	Disassembling by hand .....	27
10	Mounting options of modules with solder pins .....	28
10.1	Modules with 4 towers .....	28
10.1.1	Using screws to fix the module to the PCB.....	28
10.1.2	Using soldering jig (without using screws).....	28



## Table of Contents

10.2	Modules with 2-clips.....	29
10.2.1	Mounting options by hand: .....	29
10.2.2	Mounting with clip-in tool .....	30
11	Permitted deformations of the clips and springs .....	31
12	Recommendation for soldering .....	32
12.1	Wave soldering of modules with solder pins.....	32
12.2	Hand soldering parameters.....	32
13	ESD protection .....	33
14	Environmental conditions .....	34
14.1	Vibration resistance .....	34
14.2	Parameters of environment classes.....	34
14.2.1	Climatic conditions .....	34
14.2.2	Biological conditions .....	35
14.2.3	Chemically active substances.....	35
14.2.4	Mechanically active substances .....	36
14.2.5	Mechanical Conditions .....	36
15	Disclaimer .....	37



## Table of Contents

1. Figure: Module with PCB and heat sink .....	6
2. Figure: Chemical tin plating (for illustration only, no real proportions) .....	7
3. Figure: HAL tin plating (for illustration only, no real proportions) .....	7
4. Figure: Solder pin diameter .....	8
5. Figure: PCB-cutouts for two-clip modules at various board thickness .....	9
6. Figure: PCB cutouts for two-clip modules with Press-fit pins .....	10
7. Figure: Scratch and etching hole dimensions .....	11
8. Figure: Polished surface .....	11
9. Figure: Discoloration of substrate .....	12
10. Figure: Fingerprint on the surface .....	12
11. Figure: Thermal paste honeycomb pattern .....	13
12. Figure: Recommended thermal foil dimensions .....	14
13. Figure: Recommended torque and speed curve .....	16
14. Figure: Recommended construction for the press-in process .....	17
15. Figure: Press-in tools closed, module is pressed in .....	18
16. Figure: press-in tool for modules without thermal interface material .....	19
17. Figure: Recommended press-in tool for modules with thermal interface material .....	20
18. Figure: The recommended hole and cutout dimensions for supporting tool .....	21
19. Figure: Press-in depth in PCB .....	22
20. Figure: Typical press-in diagram of a 33 pin module .....	23
21. Figure: Exploded view of the press-out tool .....	24
22. Figure: Working position of the press-out tool .....	24
23. Figure: Recommended dimensions of the upper tool .....	25
24. Figure: Recommended dimensions of the lower tool .....	26
25. Figure: Force-path diagram of the press-out process .....	27
26. Figure: Cutting edge .....	27
27. Figure: Assembly illustration .....	28
28. Figure: Hand mounting steps .....	29
29. Figure: Clip-in tool .....	30
30. Figure: Mounting operation provided by the clip-in tool .....	30
31. Figure: Permitted deformation of the clips and springs .....	31
32. Figure: Plated through hole, good soldering .....	32
33. Figure: Typical profile for wave soldering .....	32



## Revision History

Date	Revision Level	Description	Page Number(s)
09.02.2016	05	Update in chapter: 1; 2.1; 2.4; 2.4.1; 2.4.2; 5.3; 6.2; 7; 8.1; 8.1.1.2; 8.1.2; 8.3; 10.1; 10.2; 10.3; 12; 13; 14.2.5	6, 7, 9, 10, 14, 16, 17, 19-22, 28, 29, 32, 33, 36
25.02.2015	04	Update in chapters: 1; <b>Error! Reference source not found.</b> ; 6.1; 8.1.1; 8.3; 10.2.2; 12.1; 14; 15; Removed Flow1B package & general formal update	6, 7, 14, 15, 20, 28, 30, 32, 35
01.09.2014	03	Heat sink flatness, tool cleaning, flammability classification	
17.02.2014	02	Hole diameter for soldered Press-fit	
15.11.2013	01	New document	



## 1 General assembly instructions

The *flow 1* type modules have to be mounted to a PCB. The electrical connections between module and the PCB can be made by soldering or by using Press-fit technology. In applications where the module is attached to a heat sink, the PCB must also be attached to this heat sink. Figure 1 shows how this attachment can be achieved with threaded spacers.

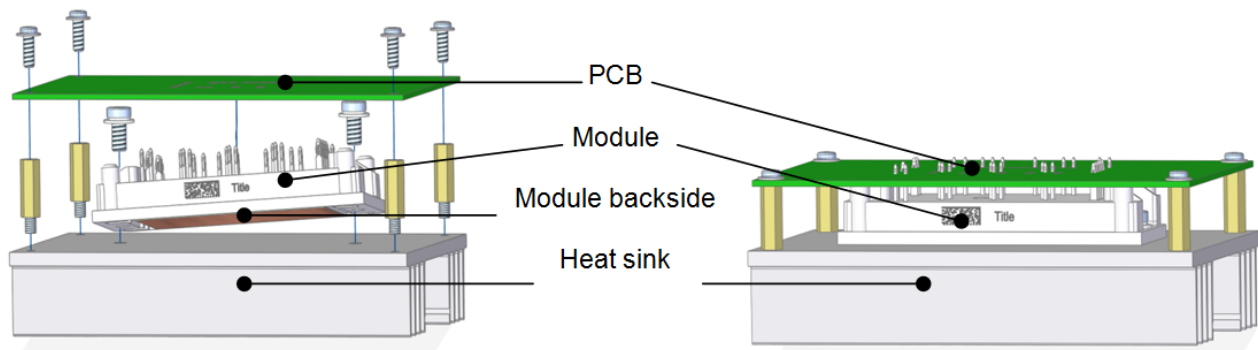

1. Figure: Module with PCB and heat sink

The distance between the top surface of the heat sink and the bottom plane of the PCB is defined by the module type, which can be 12 mm or 17 mm. PCB spacers can be used to obtain the correct spacing. The number and the position of the fixing points depend on the design of the circuit, the location of different masses like capacitors or inductors and the environment of the system. General recommendation cannot be given. For recommended heights of these spacers see the sections of mounting options (7, 10).

Typical (recommended) assembly sequence:

1. Attach module to the PCB
2. Position and fix the assembled PCB with spacers to the heat sink
3. Fix the module to the heat sink

During the assembly process, a single pin is not allowed to draw or pushed more than  $\pm 0.2$  mm or load with a force greater than 35 N (except during pressing-in of Press-fit pins). The special design of the Press-fit pins prevents higher than 0.1 mm deformation of pins during the pressing-in process.

The tension of the pin must not exceed  $\pm 5$  N at a maximum substrate temperature of 100 °C.

## 2 Specification for PCBs

- Printed board material meets the requirements of IEC 61249-2-7.
- The maximum number of conductive layers is not limited.

### 2.1 Specification for modules with Press-fit pins

- Printed board thickness must not be less than 1.6 mm (thinner PCBs require additional testing and will be performed upon request).
- PCB should be covered with solder mask on both sides.
- Plated through-hole specifications for Press-fit pin:
  - Hole diameter before plating: 1.6 mm  $\pm$  0.025 mm
  - Thickness of the PTH wall > 25  $\mu$ m Cu
  - Plated hole final dimension: 1.45 mm +0.09 mm / -0.06 mm
  - Minimum Cu width of the annular ring > 0.1 mm
  - Through hole position accuracy  $\pm$ 0.1 mm
- Plating material:
  - for chemical tin plating (Sn): 0.5  $\mu$ m to 10  $\mu$ m  
The PCB can be disassembled and reused 2 more times.

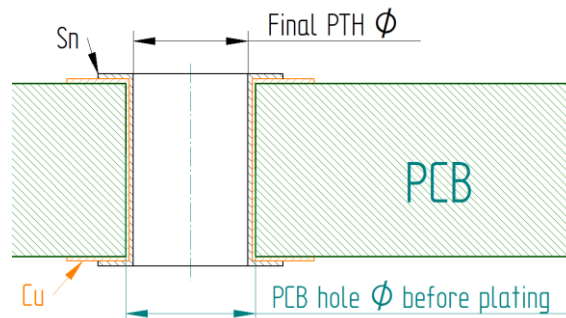

2. Figure: Chemical tin plating (for illustration only, no real proportions)

- for HAL tin plating (Sn): 0.5  $\mu$ m to 50  $\mu$ m  
The PCB can be disassembled and reused 2 more times.

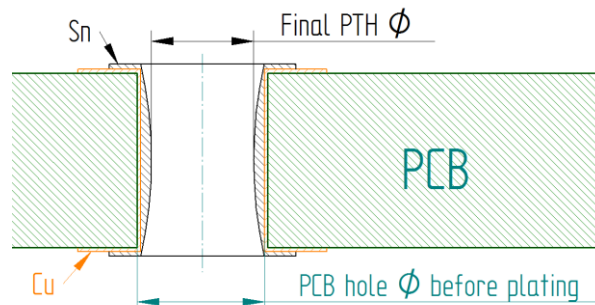

3. Figure: HAL tin plating (for illustration only, no real proportions)

- Au: not generally released; individual release of PCB system required
- Minimum distance between the edge of the PCB and the centre of the pin hole: 4 mm
- Minimum distance between the centre of the pin hole and the component on the PCB: 4 mm
- For any other requirements IEC 60352-5 standard should be considered



## 2.2 Specification for modules with solder pins

- The module is attached to the PCB by clipping or screwing it into the appropriate holes.
- The role of the clips is to hold the module in the PCB at a proper position before and during soldering process. For details see section **Error! Reference source not found.**
- After screwing the module to the PCB, all pins must be soldered. The hole diameters on the PCB have to be designed according to the soldering pin diameter which is  $\varnothing 1 \text{ mm} \pm 0.05 \text{ mm}$ .

For further dimensions or a 3D model please contact your local sales manager.

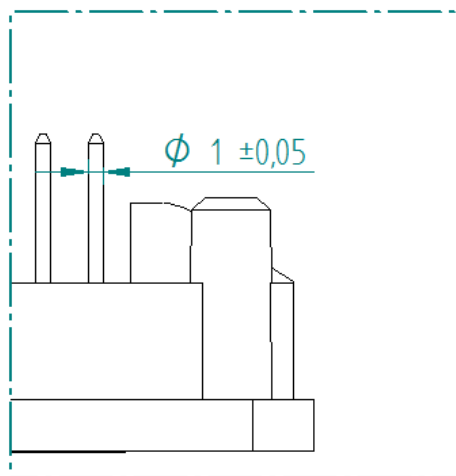

4. Figure: Solder pin diameter

## 2.3 Specification for modules with Press-fit pins that are soldered to the PCB

In cases where the Press-fit pins are soldered instead of pressed into the PCB the recommended PCB hole diameter is  $1.85 \text{ mm} \pm 0.1 \text{ mm}$ . In these cases, that the annular ring must be designed according to the standards for through hole components to ensure proper soldering of the Press-fit pins.

Please read section 122 Recommendation for soldering also.





## 2.4 Required PCB cutouts for module with clips

The drawings below show the required PCB-cutouts defined for different PCB thicknesses.

### 2.4.1 For modules with 2-clips and solder pins

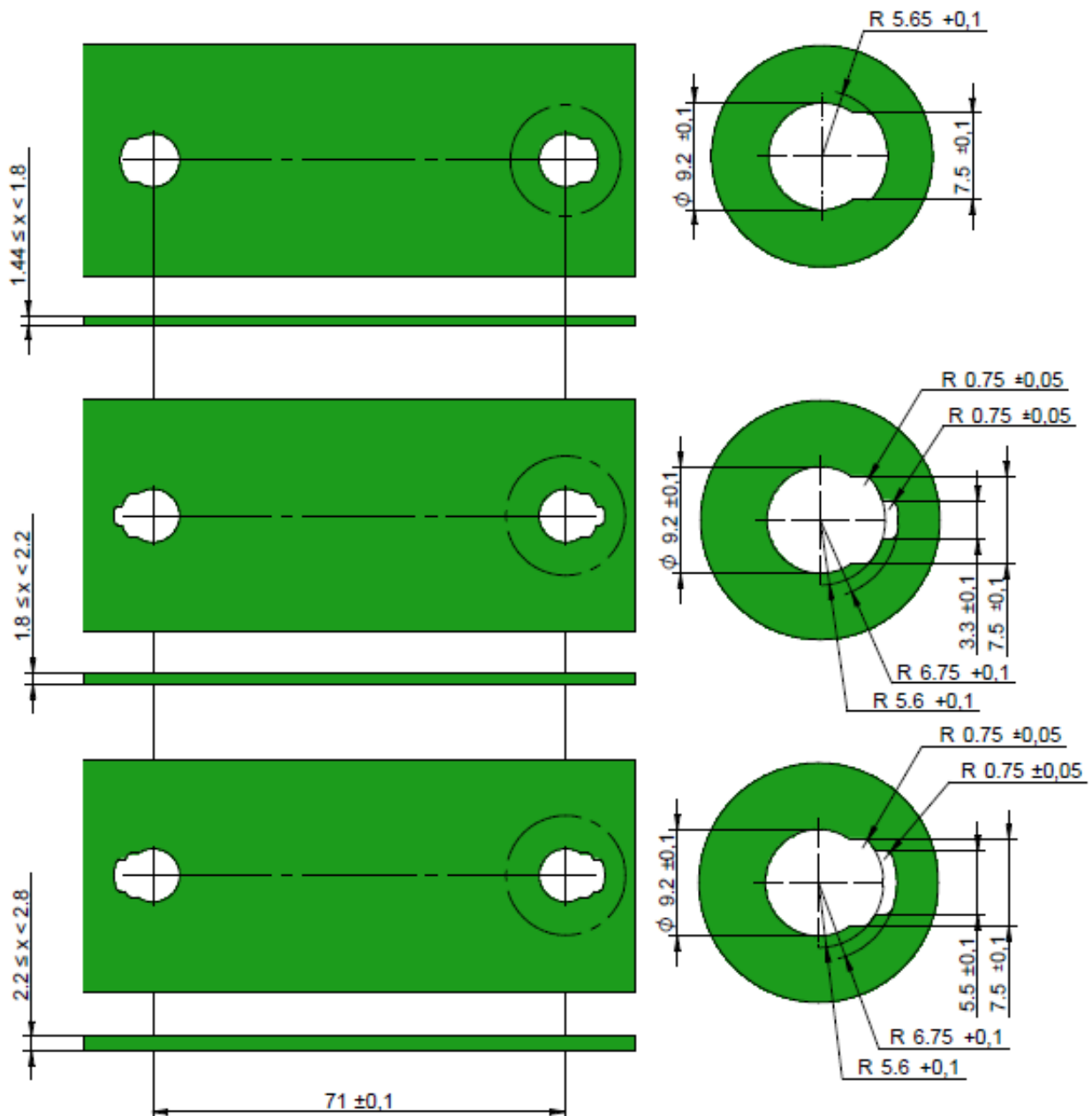

5. Figure: PCB-cutouts for two-clip modules at various board thickness



### 2.4.2 For modules with 2-clips and Press-fit pins

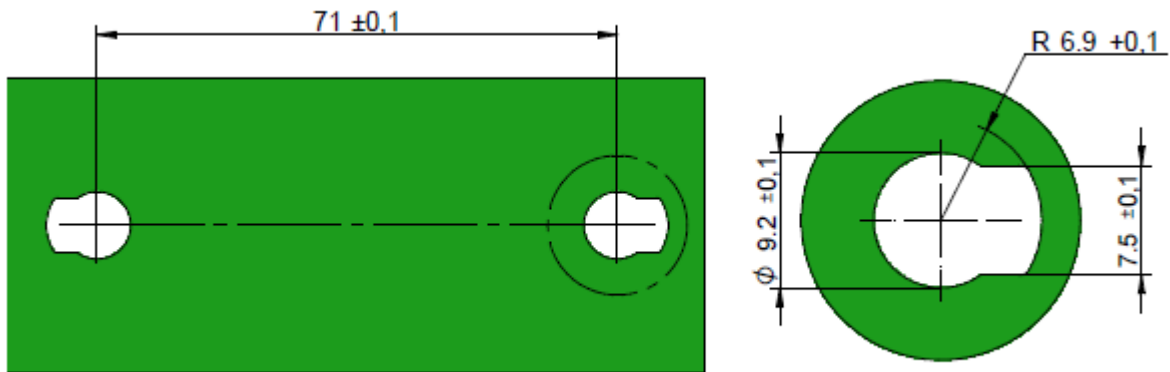

6. Figure: PCB cutouts for two-clip modules with Press-fit pins

The clips have no function in the case of Press-fit modules since the module is held by the Press-fit pins in the PCB. The press-in depth (position) is controlled by the press-in tool. The clip-in function in a Press-fit module is unnecessary because it would provide too strict positioning tolerance. Large cutouts prevent the clip-in function of the clips (see 6. Figure: PCB cutouts for two-clip modules with Press-fit pins).



### 3 Specification for module backside surface

The thermal properties are not affected if the dimensions of the surface imperfections are within the following values.

- Polishing is allowed on the whole nickel plated surface if copper doesn't become visible.
- If copper becomes visible, the unit is scratched and the following acceptance criteria should be used. The depth and width of the scratch can't exceed 200  $\mu\text{m}$  and 800  $\mu\text{m}$ , respectively. The length of the scratch does not matter but the total area of scratches must not exceed 5 % of the total substrate surface.
- The diameter and depth of etching holes have to be below 1000  $\mu\text{m}$  and 200  $\mu\text{m}$ , respectively.

Discolorations and fingerprints are only surface imperfections and do not affect the module's functionality.

Substrate surface imperfections can be seen on the figures below.

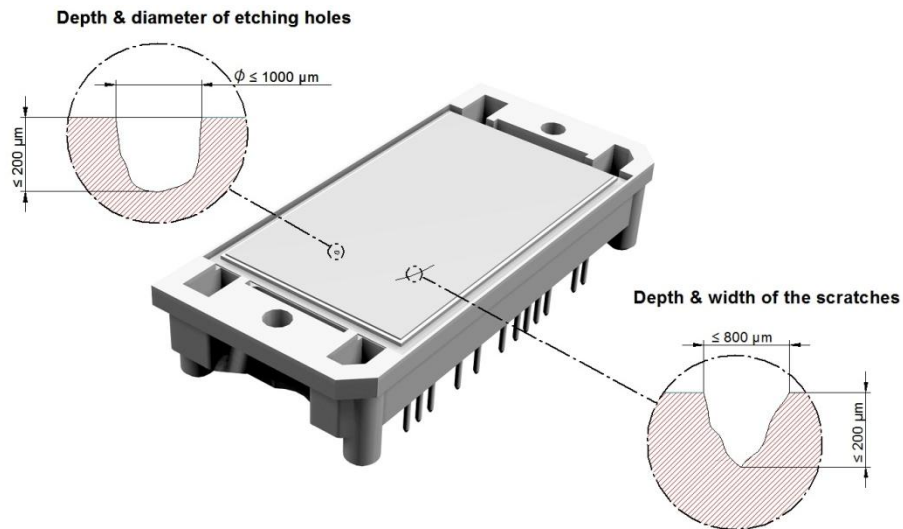

7. Figure: Scratch and etching hole dimensions



8. Figure: Polished surface



9. Figure: Discoloration of substrate



10. Figure: Fingerprint on the surface

## 4 Specification for heat sink

The whole heat sink surface under the module must be plane, clean and free of particles.

- The flatness tolerance should be:  $< 25 \mu\text{m}$  in general.
- In case the thermal paste thicker than  $50 \mu\text{m}$  the flatness tolerance can be  $< 50 \mu\text{m}$ .  
(A flatness tolerance specifies a tolerance zone defined by two parallel planes within which the surface must lie.)
- The surface roughness should be less than:  $R_z < 10 \mu\text{m}$ .
- Heat sink surface imperfections should be within the values described for the module backside surface (please refer to section 3)



## 5 Specification for thermal interface materials

### 5.1 OPTION 1: Thermal paste:

- A. Apply a homogeneous layer of thermal conductive paste over the whole backside of the module, with a roller or spatula.
- B. Apply thermal paste in a honeycomb pattern, see 11. Figure:.. The preferred technology for paste application is screen printing. For a drawing of the pattern please contact your local sales representative.

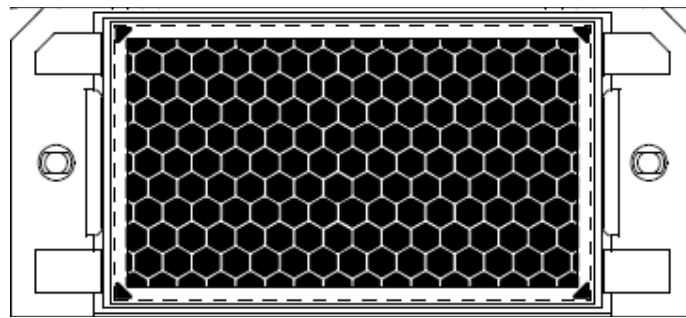

11. Figure: Thermal paste honeycomb pattern

The recommended thermal paste thickness is  $45 \mu\text{m} \pm 15 \mu\text{m}$  in both cases.  
Thermal paste thicker than recommended will increase thermal resistance ( $R_{th}$ ).

### 5.2 OPTION 2: Thermal foil:

- A thermal foil comprising of an aluminium core layer and two outer layers of phase change material should be used.
- The total thickness of the foil has to be less than  $80 \mu\text{m}$ . Thicker foils could cause the ceramic substrate to break and increase the thermal resistance.
- Recommended foil type: Kunze Folien KU-ALC5 or ALF5
- Material of the foil is aluminum, covered with a phase change material.
- Recommended foil dimensions: see 12. Figure on next page.

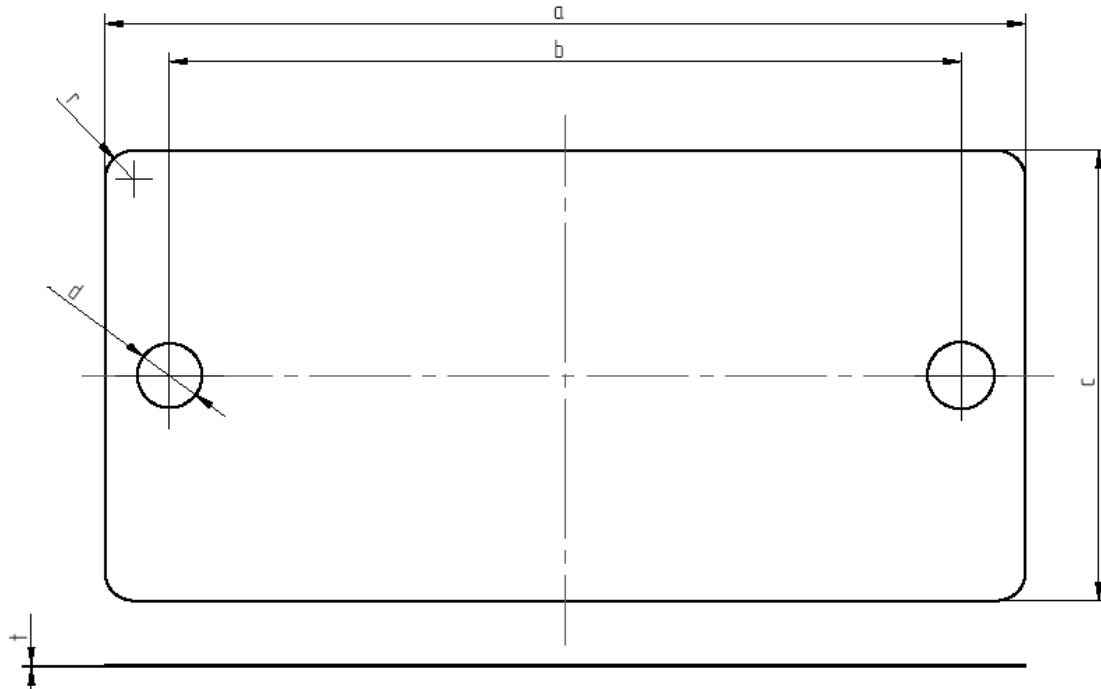

Type	<i>a</i> /mm	<i>b</i> /mm	<i>c</i> /mm	<i>d</i> /mm	<i>r</i> /mm	<i>t</i> /μm
<i>flow 1</i>	82 ± 0.15	71 ± 0.15	37.4 ± 0.15	4.5 ± 0.15	2 ± 0.15	< 80

12. Figure: Recommended thermal foil dimensions

### 5.3 OPTION 3: Pre-applied thermal interface material

- The modules may have already been pre-printed with thermal interface material.
  - For modules with Press-fit pins a unique press-in tool (see section **Error! Reference source not found.**) has to be used or the module has to be mounted first to the heat sink and then pressed into the PCB.
  - Further information about using modules with pre-applied TIM see the application note for “*Power modules with Phase-Change Material*” on Vincotech’s website



## 6 Specification for fastening screws to the heat sink

- Screws M4 (recommended screw type DIN 7984)
- Min. length of the screw in the heat sink: 6 mm
- Flat washer ISO 7092 (DIN 433) - size of outer diameter  $\varnothing$  8 mm can be fitted into the module.
- Spring washer DIN127 or DIN 128
- Mounting torque:  $1.6 \text{ Nm} < M_s < 2 \text{ Nm}$
- For modules with AIN DCB: tighten both screws with half torque first, and then tighten both screws with max. torque afterwards

A torque wrench shall be used to tighten the mounting screws at the specified torque as excessive torque may result in damage or degradation of the device. The inaccuracy of torque wrench tightening method can range up to  $\pm 12\%$ . This has to be taken into account to prevent over-tightening the fastener.

Due to excessive temperature fluctuations washers should be used to prevent the loosening of the screws. After accurate tightening of the screws the spring washer exerts a constant force on the joint. The flat washer distributes this force on the plastic surface.

### 6.1 Screw with pre-assembled washers

Screws with pre-assembled washers (SEMS or kombi screws) combine the screw and the washers into a single component. These screws eliminate the need to slip the washers into place by hand, boosting the speed and efficiency of the assembly process. The specifications of these screws are provided below:

- Screw size M4 according to DIN 6900 (ISO 10644; JIS B1188)
- Flat washer according to DIN 6902 Type C (ISO 10673 Type S; JIS B1256)  
Size of outer diameter  $\varnothing$  8 mm can be fitted into the module.
- Split lock spring washer according to DIN 6905 (JIS B1251)
- Mounting torque range:  $1.6 \text{ Nm} < M_s < 2 \text{ Nm}$



## 6.2 Mounting with automatic screwdriver

For a fast, reliable and repeatable screwing process an automatic screwdriver with two stage tightening method is recommended. The screwdriver starts fast in the first stage and slows down after the first target torque is reached to accurately tighten the screw to the final target. For torque and speed recommendations see below the curves (13. Figure) and values:

### Torque

- Cycle start: 0.3 Nm
- First target: 0.5 Nm
- Final tq min.: 1.6 Nm
- Final target: 1.8 Nm
- Final tq max.: 2 Nm

### Speed

- Soft start speed: 96 rpm
- Step 1 speed: max. 650 rpm
- Step 2 speed: max. 12 rpm

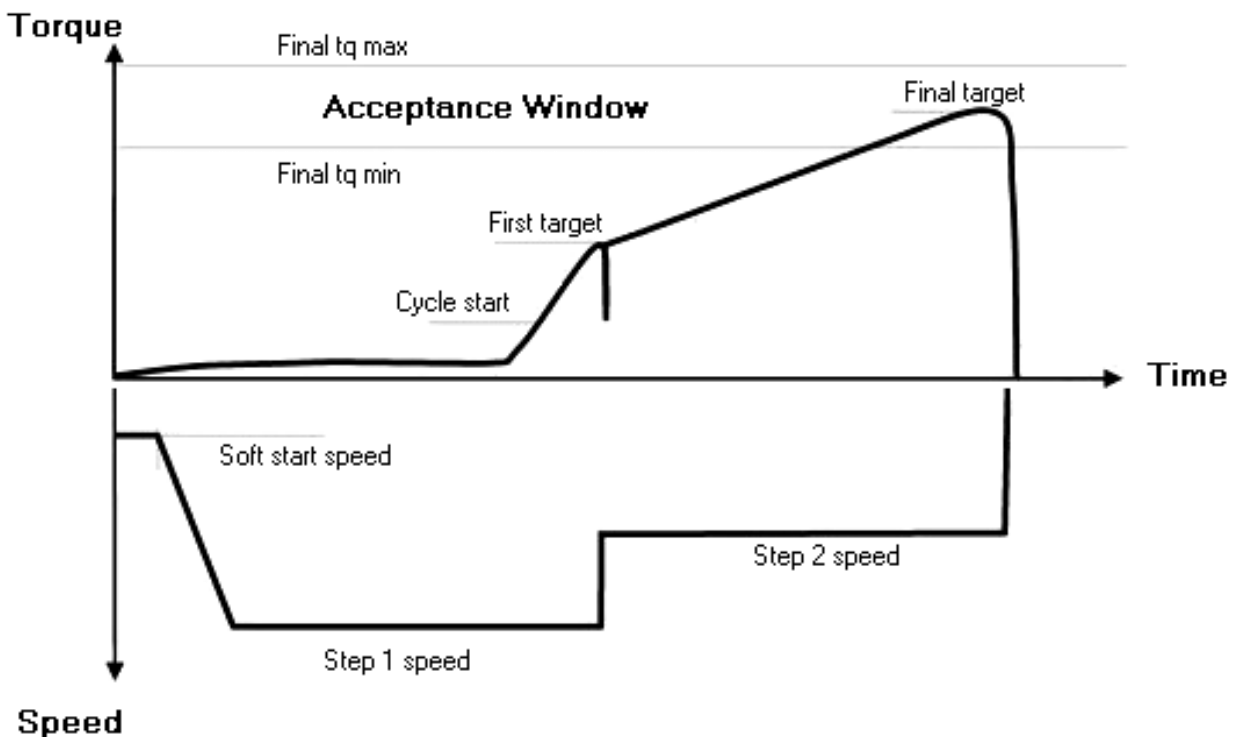

13. Figure: Recommended torque and speed curve



## 7 Mounting options of modules with Press-fit pins

- In the case of modules with Press-fit pins, the usage of the mounting by clipping or screwing to the PCB of the module is not recommended.
- Recommended spacer height:
  - $12.1^{-0.1}$  mm in the case of 12mm type modules
  - $17.1^{-0.1}$  mm in the case of 17mm type modules

## 8 Press-in process of modules with Press-fit pins

### 8.1 Press-in construction

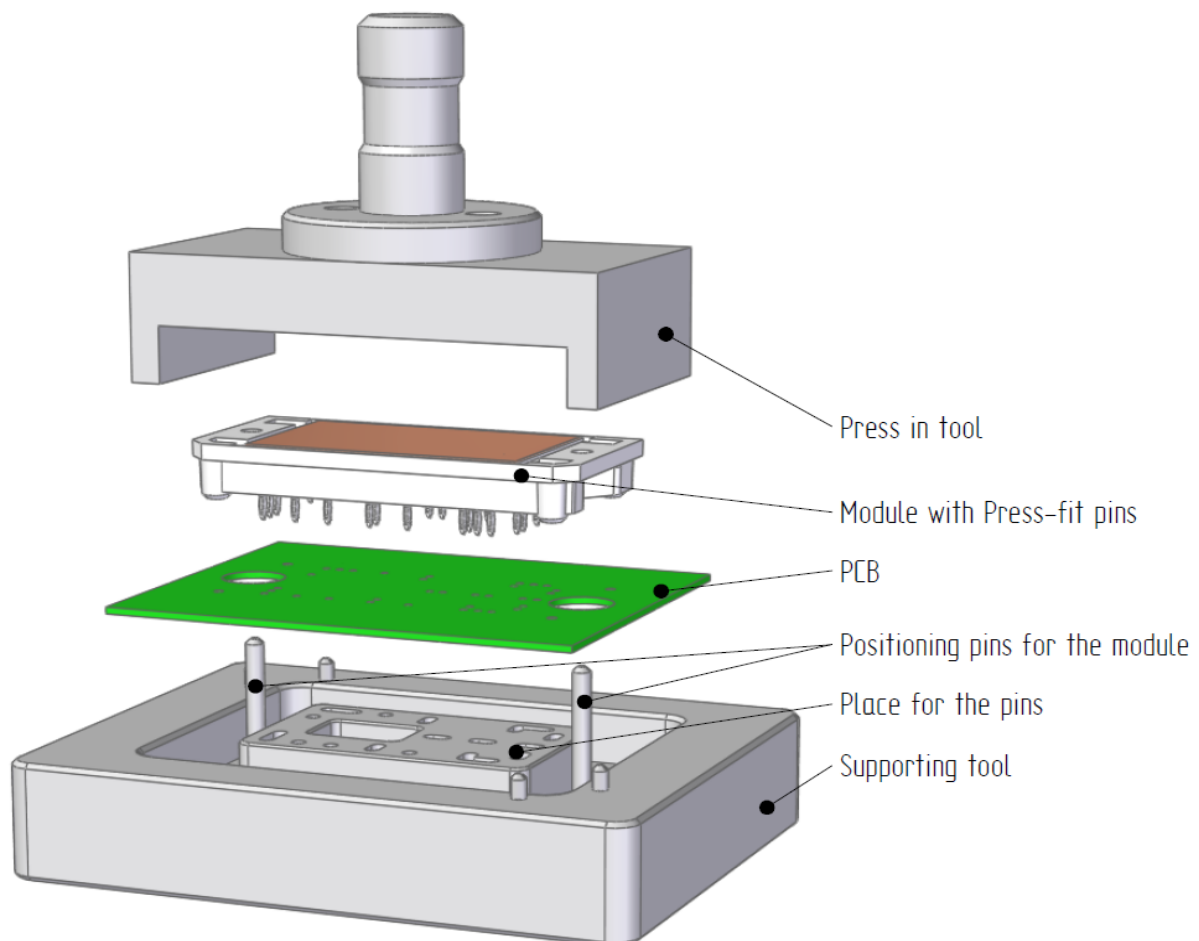

14. Figure: Recommended construction for the press-in process

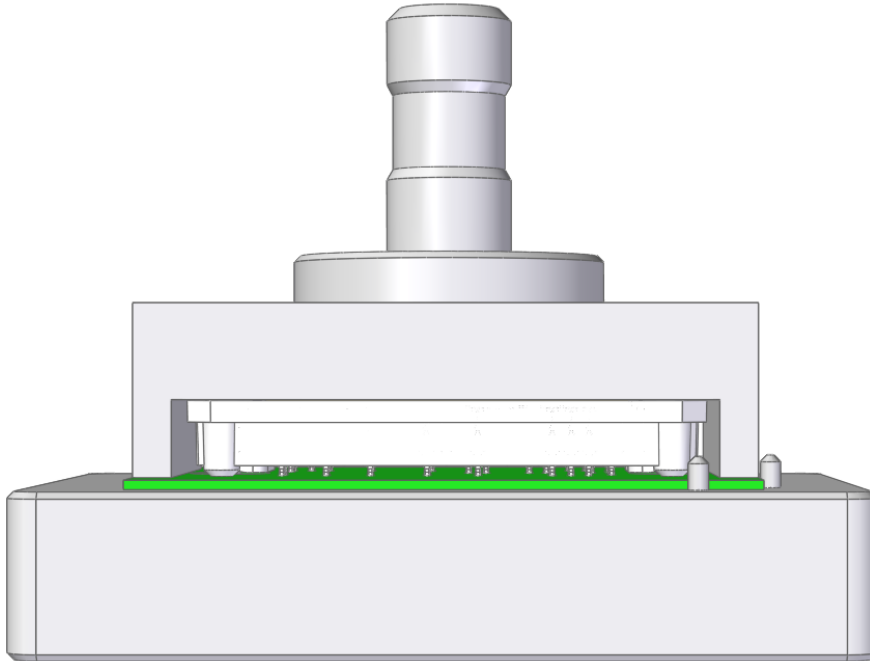

15. Figure: Press-in tools closed, module is pressed in

- The module can be pressed into the PCB from the top (as 14. Figure: shows) or the PCB can be pressed onto the module from the top (the module is below the PCB).
- The preferred method is to press the module into the PCB from the top. This method will be discussed in this document.
- Pressing multiple modules into one PCB can be done one by one (subsequently) or all at once.
- Pressing multiple modules at the same time requires a press-in tool according to the above detailed single tool. The tool has to ensure the correct leveling of the modules and PCB to avoid mechanical stress.
- The "U-shape" tool (**Error! Reference source not found.**) is only because to keep the distance between the PCB and the module. Depending on the PCB layout the geometry and the position of this distance keeper can be different. Minimum distance between tool and the components on the PCB: 4 mm

### 8.1.1 Press-in tool

The press-in tool protects the module from being over pressed.

#### 8.1.1.1 Modules without thermal interface material

Material requirements for the press-in tool:

- Tool steel grade 21 MnCr 5 with yield strength of 660 MPa and hardness of 330 HB or better.
- Maintenance: Due to inherent contamination from process and product tolerance differences, it is recommended to clean the press-in tool regularly

The dimension marked with 'x' on the drawing (16. Figure:) depends on module height:

- $12.1^{+0.05}$  mm in the case of 12 mm modules
- $17.1^{+0.05}$  mm in the case of 17 mm modules

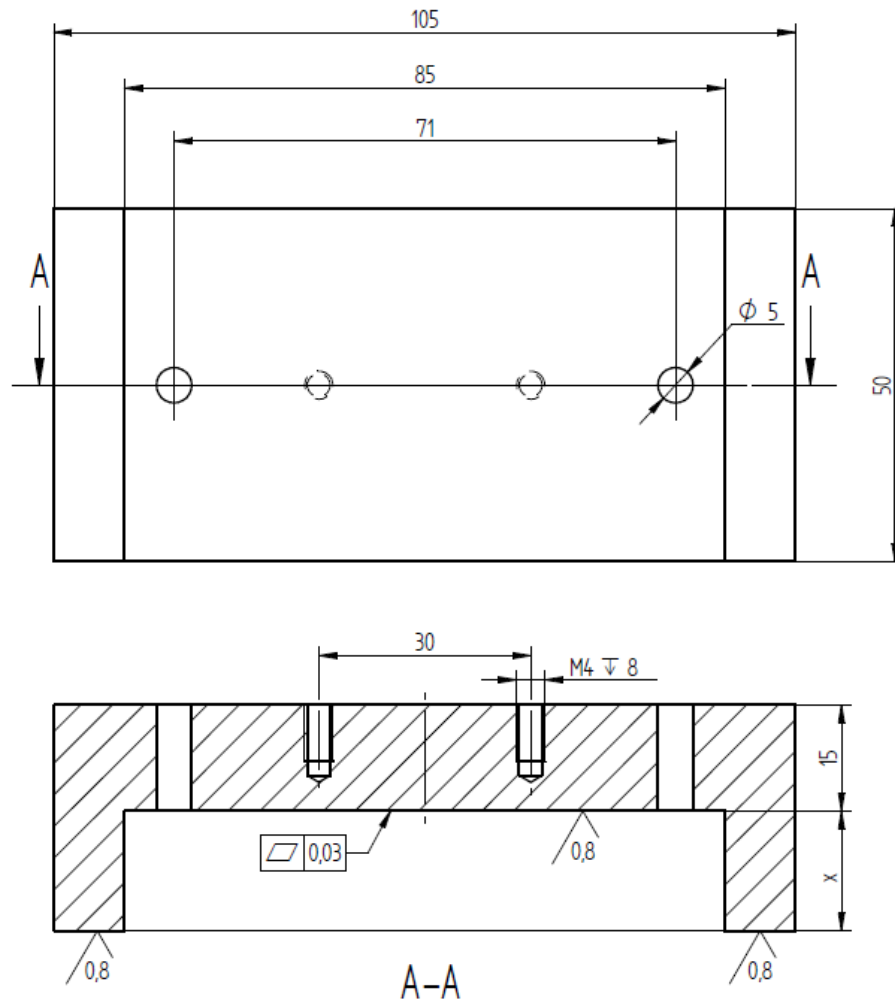

16. Figure: press-in tool for modules without thermal interface material

### 8.1.1.2 Modules with thermal interface material

A unique press-in top tool shown in Figure 16 is needed to prevent significant damage to the phase change material during the press-in process. Small damages (max:  $\varnothing 0.6$  mm) are allowed.

Requirements for the press-in tool:

- Tool steel grade 21 MnCr 5 with yield strength of 660 MPa and hardness of 330 HB or better.
- Maintenance: Due to inherent contamination from process and product tolerance differences, it is recommended to clean the press-in tool regularly. The desired cleaning interval is once every 100 modules with soft wipes soaked in Isopropyl alcohol.

The dimension marked with 'x' on the drawing 16. Figure: is depends on module height:

- $12.1^{+0.05}$  mm in the case of 12 mm modules
- $17.1^{+0.05}$  mm in the case of 17 mm modules

For more information or a 3D model please contact your local sales manager.

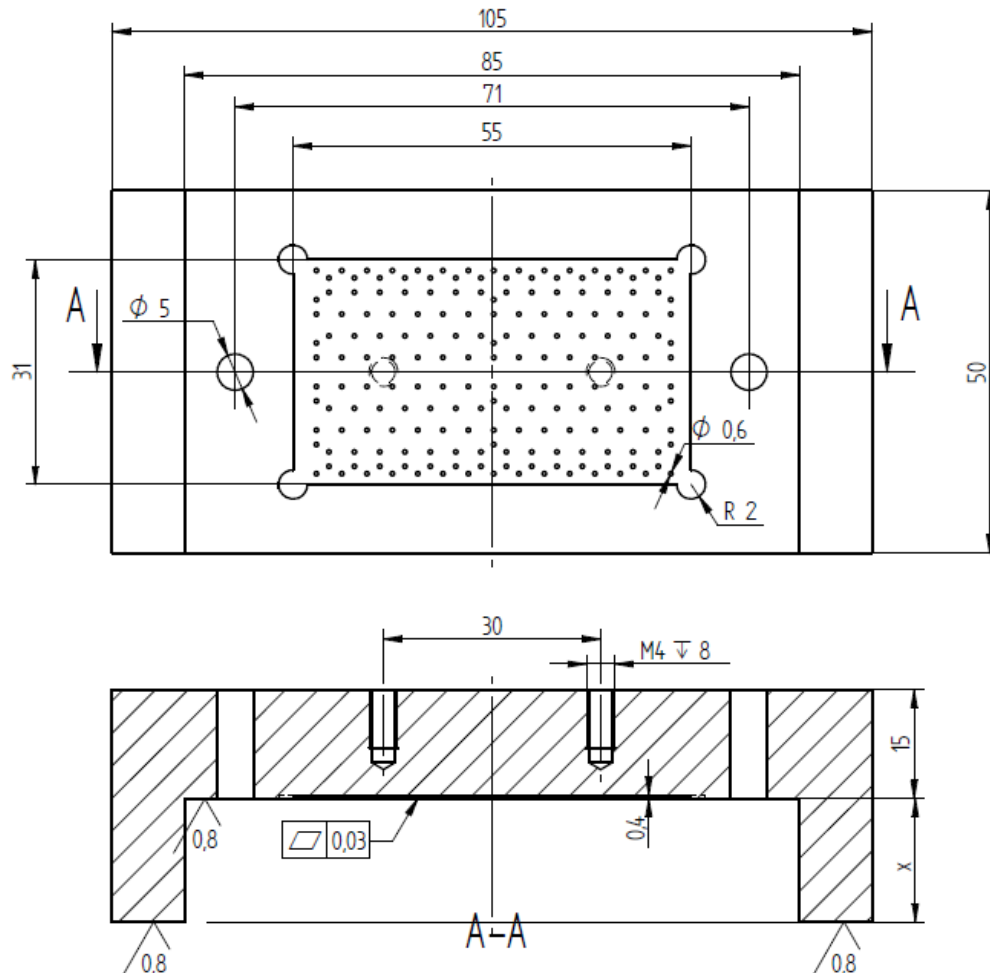

17. Figure: Recommended press-in tool for modules with thermal interface material

### 8.1.2 Supporting tool

- The supporting tool supports the PCB during the press-in process. The size and position of the holes and cut-outs depends on the components on the PCB.
- 18. Figure: shows the recommended hole and cut-out dimensions for the Press-fit pins. The recommended diameter of the holes / cut-outs for the pins in the supporting tool is between 1.7 mm and 4 mm (depending on the positioning accuracy). The minimal supporting place around the hole is 2 mm (the min. distance of PCB components from the PCB pinhole should be also considered here). If the pins are close to each other then it is possible to make a lengthwise cut-out for more pins as well. It is necessary to position the PCB and the module as well. The depth of the cut-outs for the pins is 6 mm.
- The module can be positioned with pins from the bottom tool through the fixing holes of the modules.
- Material of the supporting tool: POM (Polyoxymethylene) ESD proof or any metal alloy.
- The thickness of the supporting tool has to be at least 20 mm.

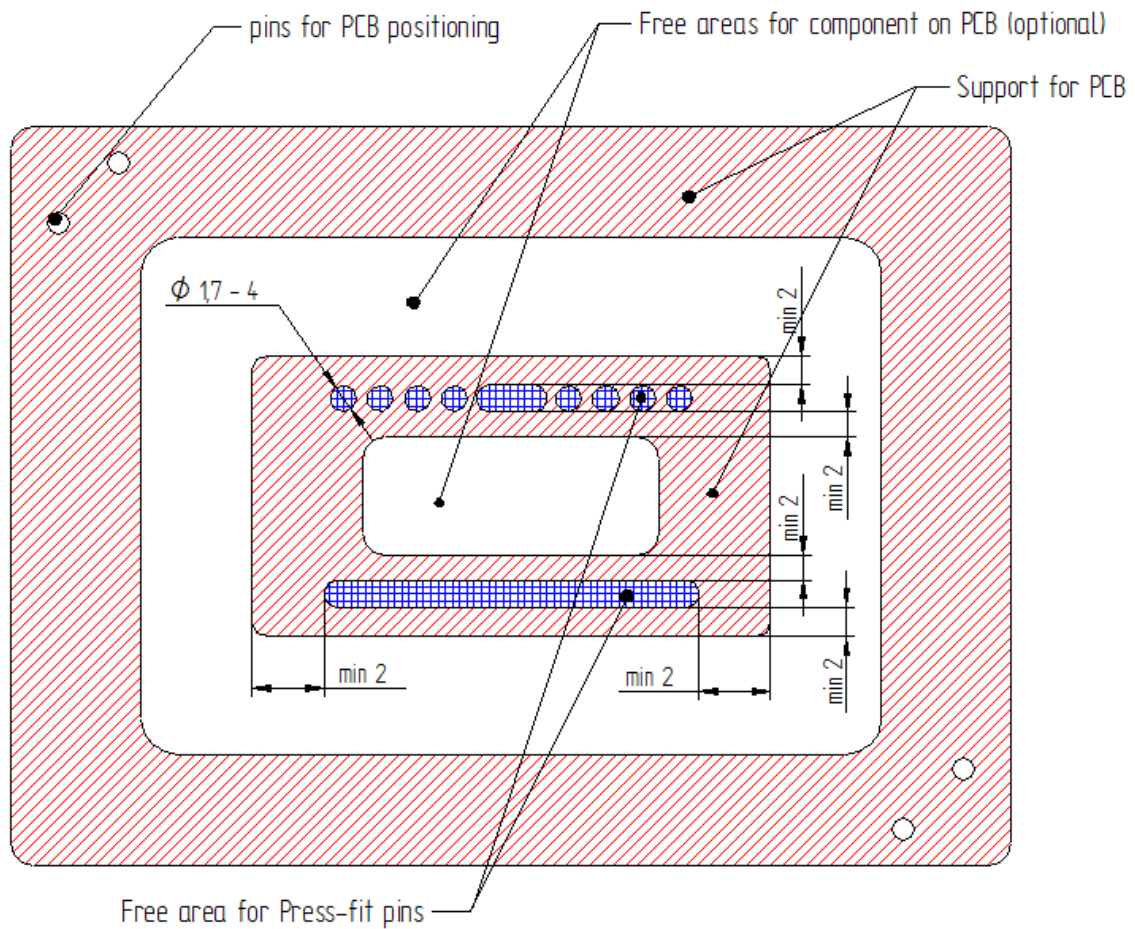

18. Figure: The recommended hole and cutout dimensions for supporting tool

## 8.2 Press-in process parameters

The total press-in force depends on the number of the pins the hole-diameter and the plating (type/quality) of the PCB.

- Press-in force: 70 N/pin to 160 N/pin
- Press-in speed: 5 mm/s to 10 mm/s

### 8.2.1 Basic requirements for the press-in process

The Press-fit pins have to be pressed to the correct depth into the holes of the PCB. The center of the Press-fit pin head has to be at least 0.5 mm below the top surface and at least 0.5 mm above the bottom surface of the PCB. (19. Figure:).

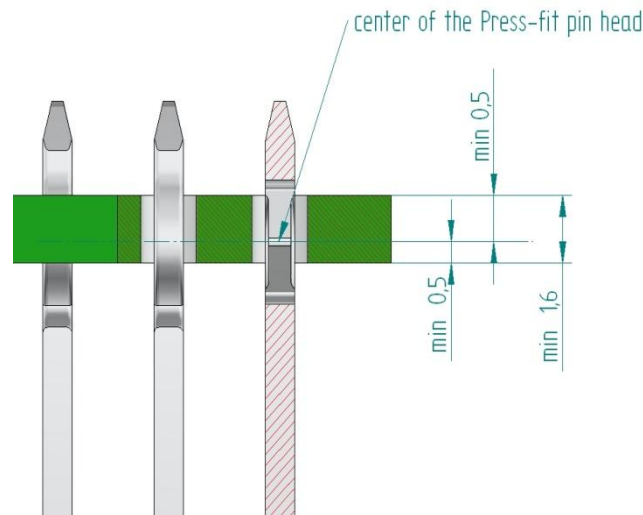

19. Figure: Press-in depth in PCB

This condition is automatically fulfilled with the use of the recommended press-in tool. 15. Figure: shows the closed press-in tool with the module.

### 8.3 Process control parameters

If the press machine is equipped with the possibility to record the force-stroke values during the process, the following quality relevant values should be taken into consideration. 20. Figure: shows a normal press-in diagram.

Three different sections can be seen on the diagram:

- First raising section (blue): The heads of the Press-fit pins slide into the holes and deform to fit in the holes. This section ends with a local maximum.
- Second section (green): The pin slides in the holes to reach the final position. The centre of the pin heads are inside the holes and do not deform any longer. This section ends with a local minimum.
- Second raising section (red): press-in tool touches the PCB and the sliding of the pins is stopped. The press-in tool starts to bend the PCB.

The pressing-in has to be stopped at the beginning of the second raising section, not exceeding the actual max force of the first rising section, to avoid damaging the PCB or the deformation of the plastic housing. The press-in force or the motion stroke of the tool has to be controlled to stop at the beginning of the second raising section.

Possible process control parameter settings are as follows:

- The local maximum value (end of blue section) of the force-stroke diagram has to be:
  - higher than 70 N x number of the pins,
  - smaller than 160 N x number of the pins.

These limits are marked on the diagram. If the press-in force does not fit in the interval defined above, it can indicate faulty plating, or improper diameter of the holes.

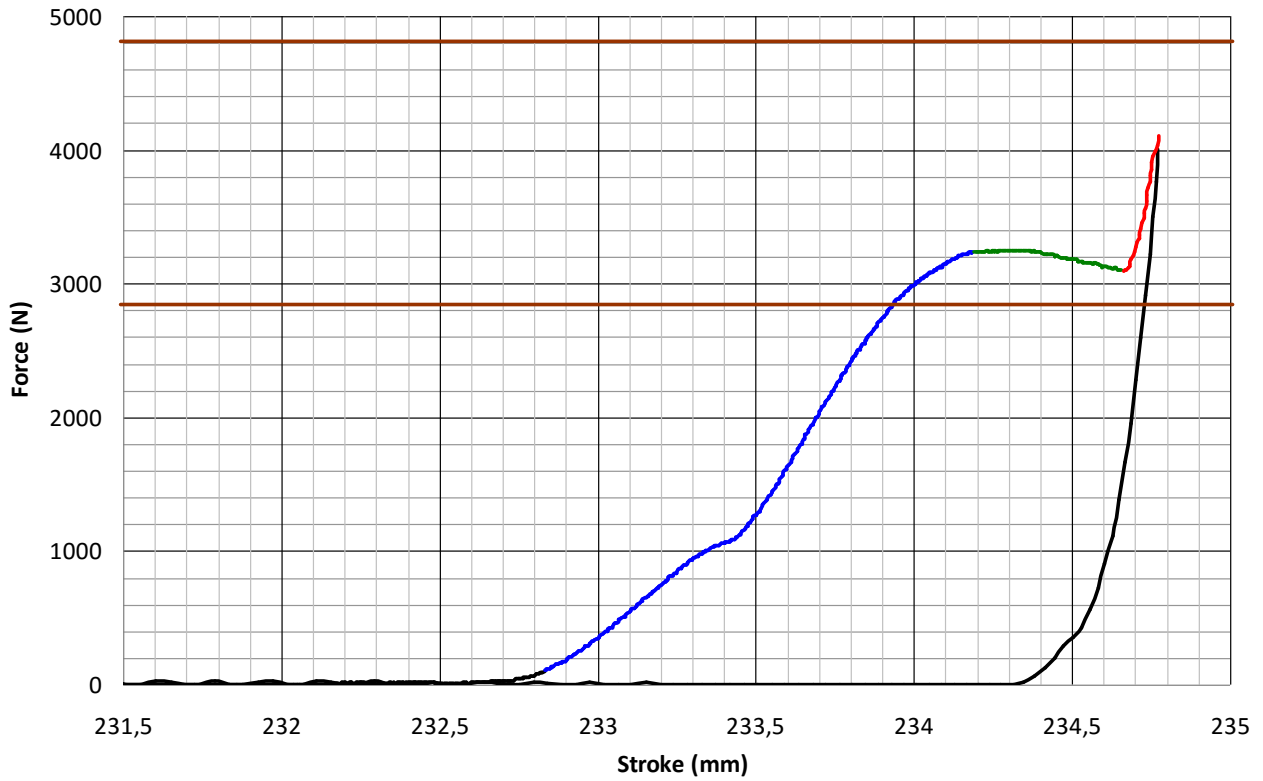

20. Figure: Typical press-in diagram of a 33 pin module



## 9 Press-out process for modules with Press-fit pins

Please note: In the case an out-pressed module should be used again, it is necessary to solder the module to the PCB because of the remaining deformation of the pins. This is because the Press-fit zone will keep a remaining deformation after the press-out process. An additional press-in cycle will result in low holding forces between the Press-fit pin and the PCB hole. Additional information for the annular ring can be found in section 2.3

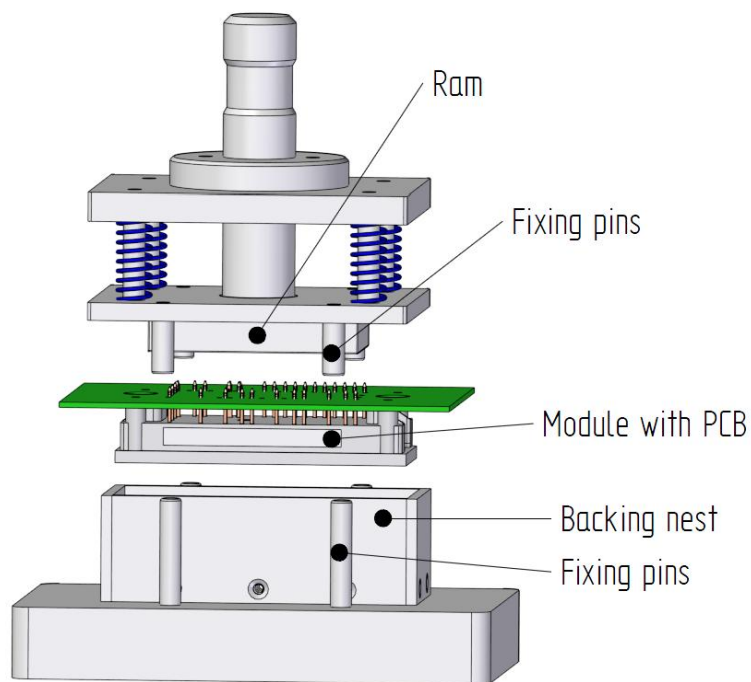

21. Figure: Exploded view of the press-out tool

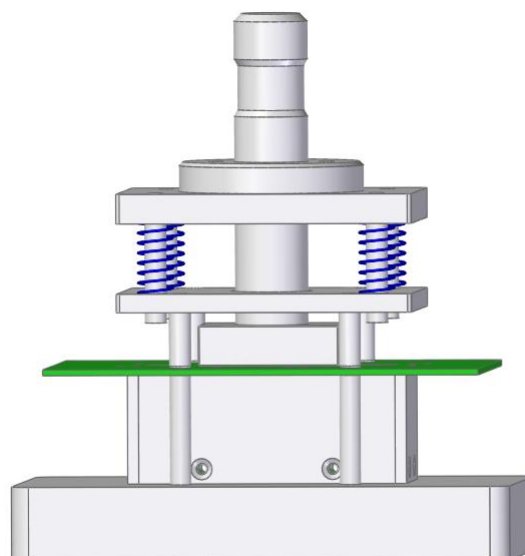

22. Figure: Working position of the press-out tool





### 9.1 Press out tool

The specific tool to disassemble the modules from the PCBs has two parts, similar to the press-in tool. The lower part serves as a backing for the PCB. It has a backing nest and supporting pins. It is important that the backing has to be as close as possible to the side of the modules. The supporting pins are in line with the fixing pins of the upper part. There may be components mounted to the PCB in the area of the backing. It is possible to cut out the nest in this case.

The upper part consists of two pressing plates that are connected by springs. The pins on the lower plate serve to fix the PCB. With the aid of these parts, the bending of the PCB can be prevented during pressing.

The ram fastened to the upper plate is designed according to the positions of the parts on the PCB and the layout of the pins.

It is not possible to press the module out with a flat plate if the PCB is thicker than 2.5 mm, due to the overhang of the pins. In this case, pressing sticks positioned according to the pin layout are necessary.

- Recommended spring force: 25 N/mm
- Recommended number of springs: 4 Pieces

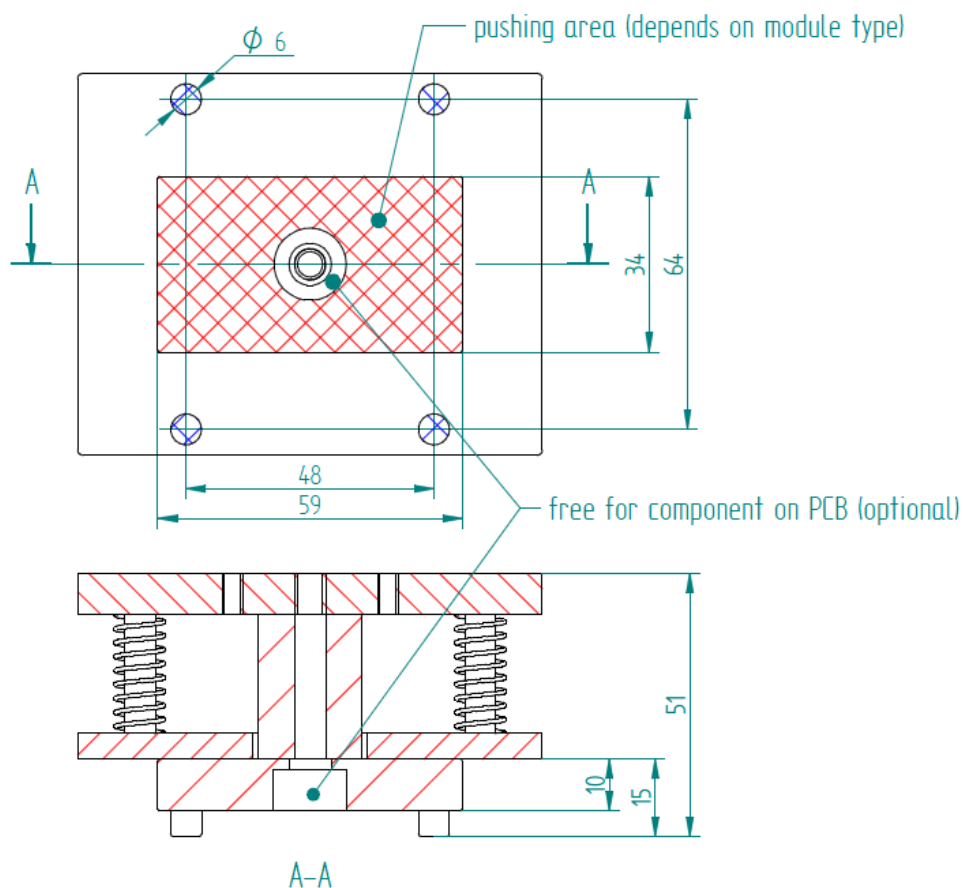

23. Figure: Recommended dimensions of the upper tool

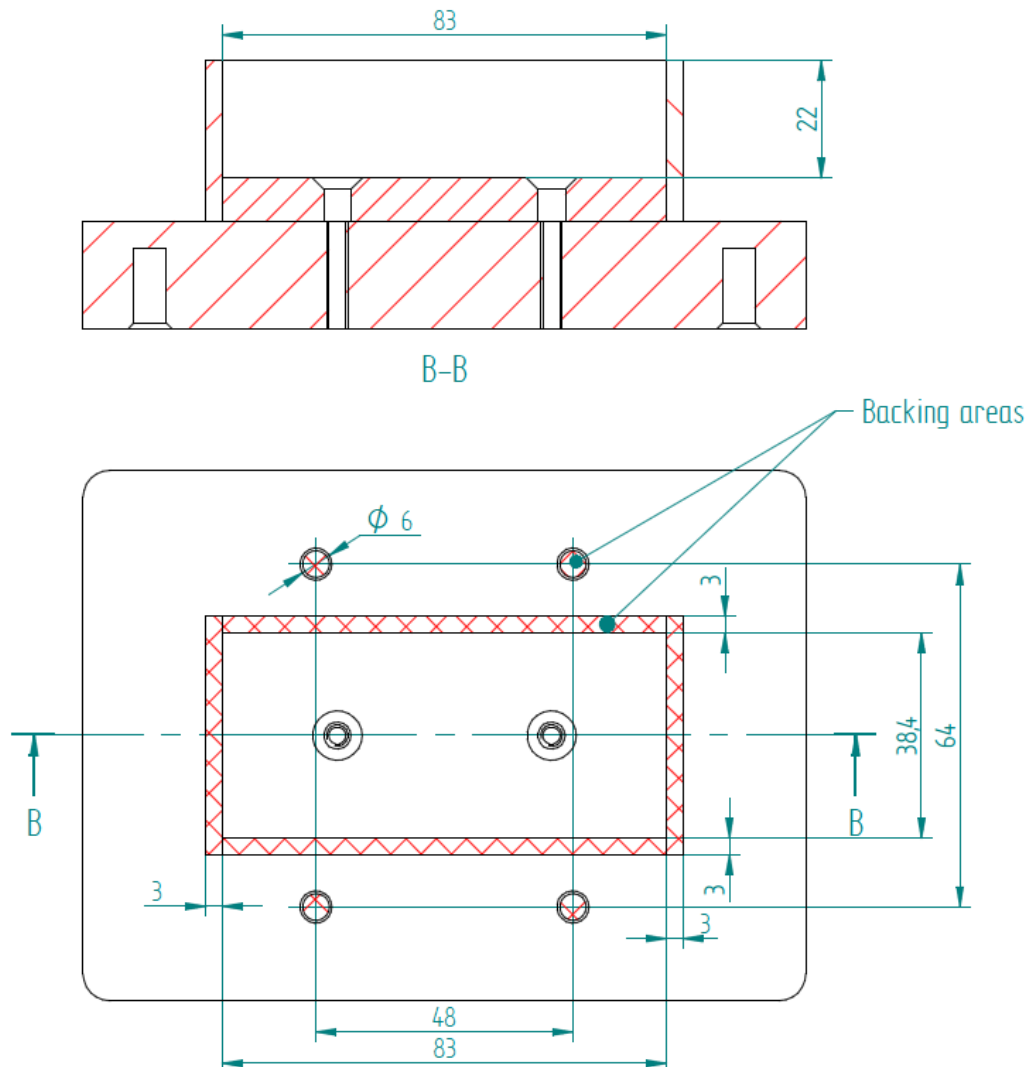

24. Figure: Recommended dimensions of the lower tool

## 9.2 Press-out process characteristics

After inserting the module into the nest, the downward moving press fixes the PCB with the lower plate through the springs. The pins are pressed through by the onward moving pressing ram.

25. Figure: shows a typical force-distance diagram of the press-out process for a 33 pin module. It is typical for this curve that a characteristic peak appears which indicates the breaking of the cold welded connection.

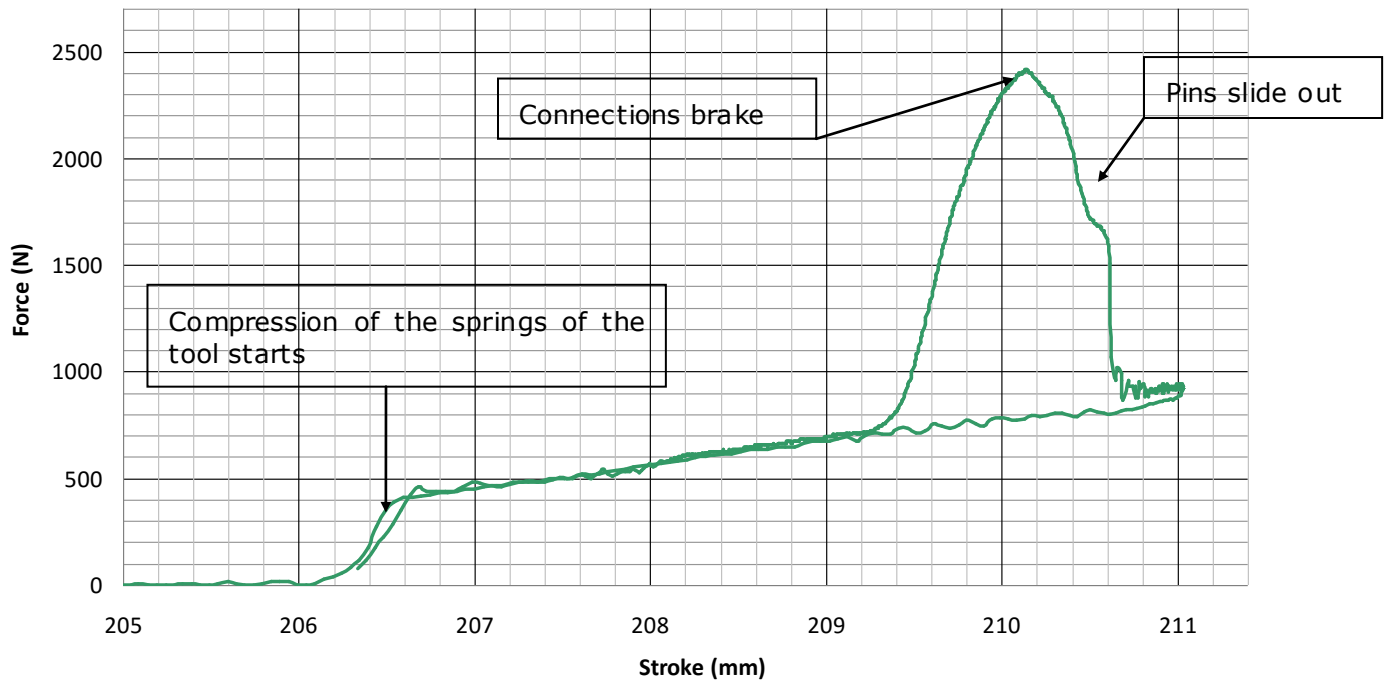

25. Figure: Force-path diagram of the press-out process

### 9.2.1 Press-out process parameters

- Press-out force: Higher than 40 N/pin
- Press-out speed: 2 mm/s to 5 mm/s

### 9.3 Disassembling by hand

If the Press-fit pin-head is overlapped by the PCB in such a way that the spring-end is out of the PCB, the disassembling is possible with hand pliers. The cutting should be done in a way that the cutting edge is under the area where the two parts of the pin head join shown as level 'A-A' in 26. Figure: After clipping away all of the pin-heads, it is possible to remove the module from the PCB.

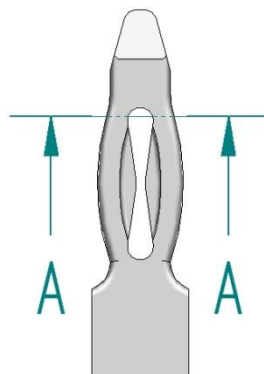

26. Figure: Cutting edge



## 10 Mounting options of modules with solder pins

### 10.1 Modules with 4 towers

- for minimum overhang of pins IPC-A-610E standard and module datasheet drawing should be considered

#### 10.1.1 Using screws to fix the module to the PCB

- Insert the module pins into the PCB
- Fix the module to the PCB with 4 screws by the towers before soldering (for screws min.  $\varnothing 2.8$  mm hole is needed on PCB)
- Screw type: BN82428,  $D = 2.5$  mm and  $L = 6$  mm with a mounting torque: 0.4 Nm.
- Recommendation for spacer:
  - not necessary to use surrounding the module
  - general height:
    - $11.9^{+0.05}$  in the case of 12 mm modules
    - $16.9^{+0.05}$  in the case of 17 mm modules

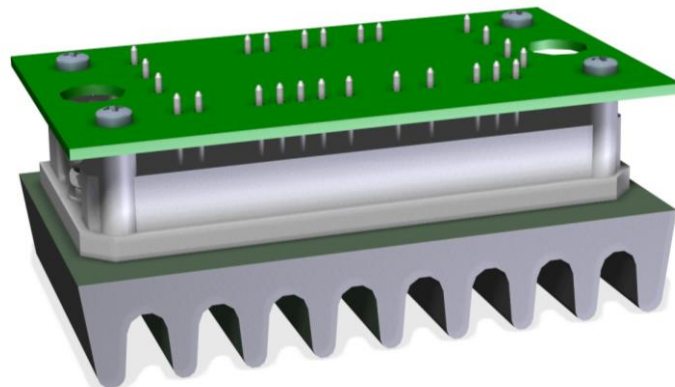

27. Figure: Assembly illustration

#### 10.1.2 Using soldering jig (without using screws)

- Insert the module pins into the PCB
- Fix the module to the PCB with soldering jig before soldering
- Recommendation for spacer:
  - use spacers also surrounding the module
  - general height can be variable: has to be adjusted, depending on height of soldering jig and PCB thickness



## 10.2 Modules with 2-clips

- spacer height depends on PCB thickness, calculated as follows:

PCB thickness [mm]	$1.4 \leq S < 1.8$	$1.8 \leq S < 2.2$	$2.2 \leq S < 2.6$
Height of module clip [mm] 2-clips and 12mm type:	<b>H =</b> 13.65	<b>H =</b> 14.15	<b>H =</b> 14.65
height of spacer [mm]	<b>h = H - S ±0.05</b>		

### 10.2.1 Mounting options by hand:

- Insert the module pins into the PCB and clip in the module (see 28. Figure:)
- Burrs are not allowed on the PCB-cutouts
- The necessary force for pushing the clips is
  - 12 N in case of 17 mm modules/side
  - 40 N in case of 12 mm modules/side
  -

---

1. Insert the module pins to the PCB and press one arbitrary side of the module gently as shown below, until two clips of that side are locked

---

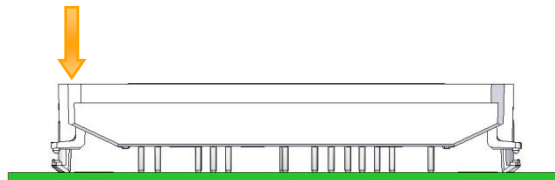

---

2. Press the other side to lock the remaining two clips as shown on the figure below

---

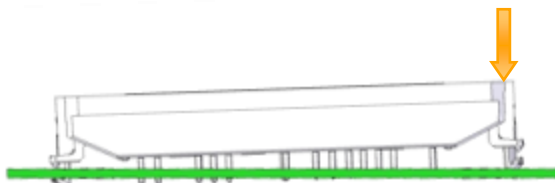

---

3. The mounted module on PCB

---



28. Figure: Hand mounting steps



### 10.2.2 Mounting with clip-in tool

In case the cutout on the PCB has sharp edges (milled or drilled), or the PCB is not coated by lacquer, it is strongly recommended to use an auxiliary clip-in tool (see 29. Figure:) as it makes the mounting easier.

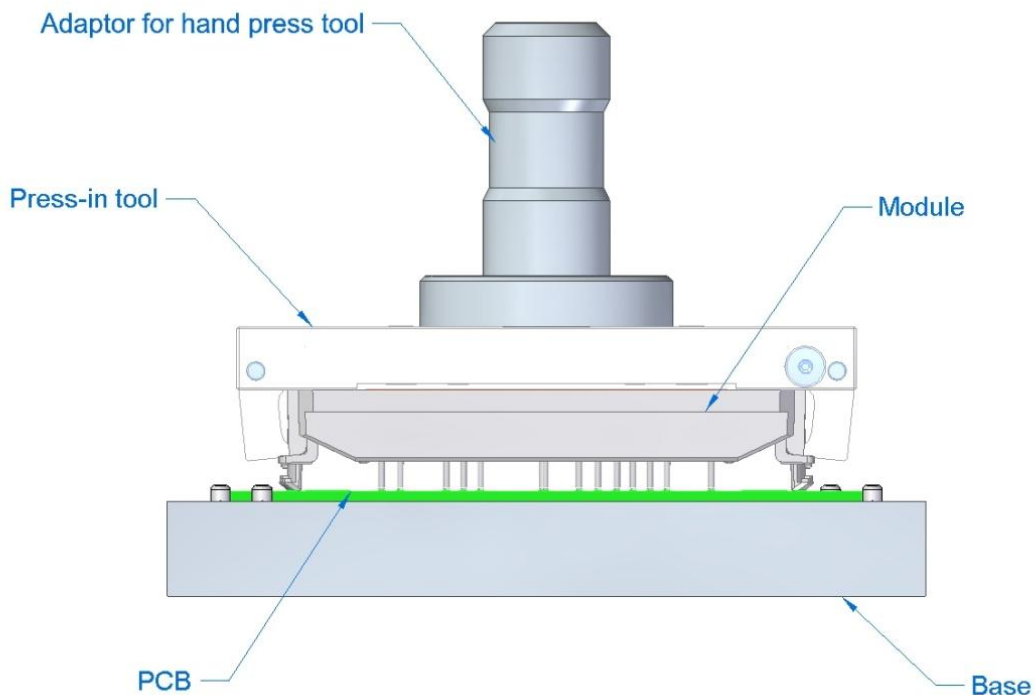

29. Figure: Clip-in tool

---

#### Mounting operation by clip-in tool

---

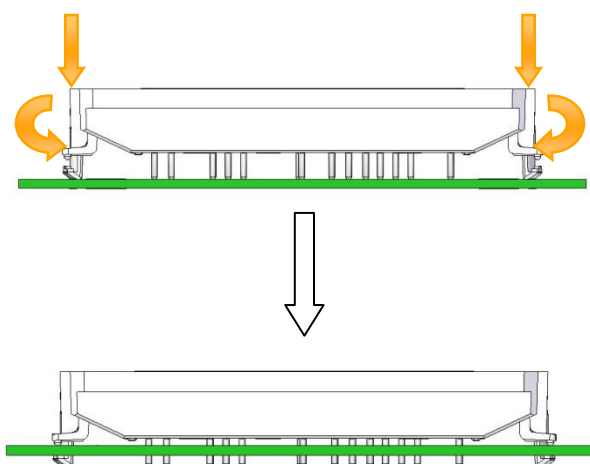

30. Figure: Mounting operation provided by the clip-in tool

For more information or a 3D model please contact your local sales manager.



## 11 Permitted deformations of the clips and springs

The allowed direction of deformation of clips and the springs is shown on by the green arrow in the 31. Figure:.

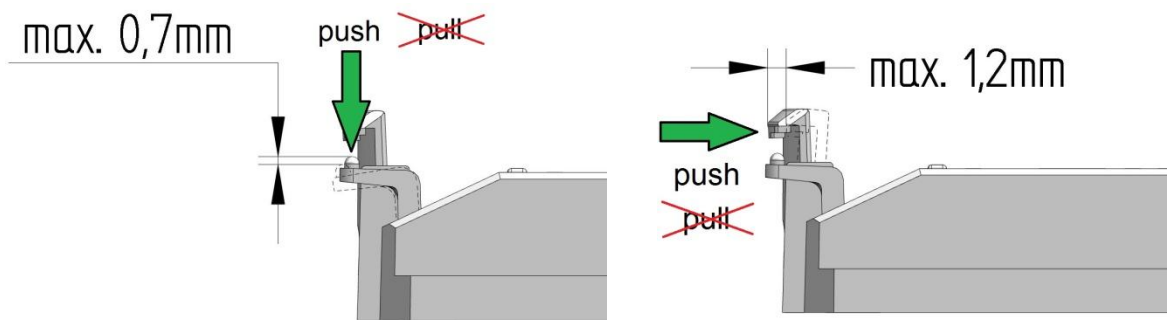

31. Figure: Permitted deformation of the clips and springs

Maximum allowable force and displacement on the clip and springs:

	<b>Max. displacement</b>	<b>Max. force</b>
Clip	1.2 mm	30 N
Spring	0.7 mm	35 N

## 12 Recommendation for soldering

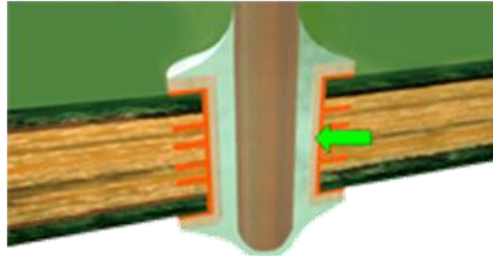

32. Figure: Plated through hole, good soldering

Plated through holes should exhibit a vertical solder fill of 75 %, with a fully formed fillet on the solder side and evidence of 75 % wetting on the component side lead, barrel and pad.

### 12.1 Wave soldering of modules with solder pins

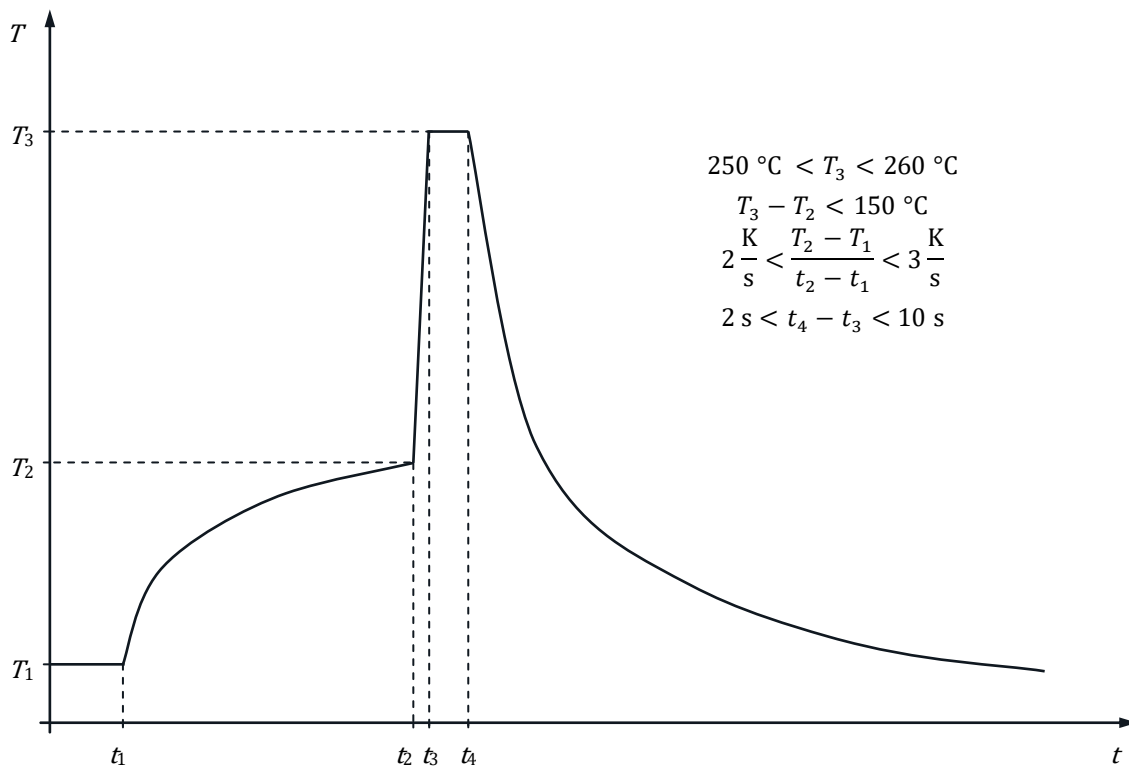

33. Figure: Typical profile for wave soldering

Soldering of certain modules with Press-fit pins is also possible using the wave soldering process. Wave soldering cannot be performed on all type of Press-fit modules.

### 12.2 Hand soldering parameters

- Max. solder iron temperature: 350 °C
- Max. contact time with component lead: 10 s
- Number of heat cycles: 3





## 13 ESD protection

Modules are sensitive to electrostatic discharge which can damage or destroy sensitive semiconductors. All modules are ESD protected in the shipment box by semi conductive plastic trays. During the handling and assembly of the modules it is recommended to wear a conductive grounded wrist band and ensure a conductive grounded working place.

Please take into consideration the following standards for handling electrostatic-sensitive devices: EN61340-5-1, ANSI S20.20



## 14 Environmental conditions

The modules can be subjected to environmental conditions characterized by the following classes:

Storage:	1K2 / 1B1 / 1C1 / 1S2 / 1M2
Transportation:	2K2 / 2B1 / 2C1 / 2S1 / 2M2*

These classes are defined in the IEC 60721-3-1 and IEC 60721-3-2 standards. The modules with wire pins have 1 year shelf life and the modules with Press-fit pins have 2 years shelf life with the given storage conditions.

Flammability classification of the plastic material for *flow 1* are V-0 and 5-VA (self-extinguishing, no dripping of flaming particles) according to UL 94, IEC 60695-11-10 and IEC 60695-11-20 test methods.

### 14.1 Vibration resistance

In addition to the vibration parameters defined in 1M2 and 2M2 classes, the *flow 1* package modules are qualified with the environmental test in accordance to the standard IEC 60068-2-6:2007 standard with the following severity:

Frequency range:	10 Hz to 26.6 Hz
displacement amplitude:	3.5 mm (7 mm peak-to-peak)
Frequency range:	26.6 Hz to 500 Hz
peak acceleration:	10 G (98.1 m/s <sup>2</sup> )
Duration:	2 hours
Number of axes:	3

These parameters are more severe than the parameters of the 1M2 and 2M2 classes.

### 14.2 Parameters of environment classes

The parameters detailed below are for informative purposes only. This section does not substitute the above mentioned standards. Please read the IEC 60721-3-1 and IEC 60721-3-2 standards for the description of the environment classes.

#### 14.2.1 Climatic conditions

1K2

Air temperature:	5 °C to 40 °C
Humidity:	5 % to 85 % RH but max. 1 g/m <sup>3</sup> to 25 g/m <sup>3</sup> absolute
Rate of change of temperature:	0.5 °C/min
Air pressure:	70 kPa to 106 kPa
Solar radiation:	700 W/m <sup>2</sup>
Movement of surrounding air:	1 m/s
Condensation:	No
Precipitation:	No
Water from other sources than rain:	No
Formation of ice and frost:	No



## 2K2

Temperature:	-25 °C to 60 °C
Change of temperature air/air:	±25 °C
Relative humidity not combined with rapid temperature changes:	max. 75 % (at 30 °C temperature)
Relative humidity combined with rapid temperature changes:	No
Low air pressure:	70 kPa
Change of air pressure:	No
Solar radiation:	700 W/m <sup>2</sup>
Movement of surrounding air:	No
Precipitation:	No
Heat radiation:	No
Water from other sources than rain:	No
Wetness:	No

### 14.2.2 Biological conditions

#### 1B1

Flora and fauna: Negligible

#### 2B1

Flora and fauna: No

### 14.2.3 Chemically active substances

#### 1C1

Sea and road salts:	No (Salt mist may be present in sheltered locations of coastal areas.)
Sulphur dioxide:	0.1 mg/m <sup>3</sup>
Hydrogen sulphide:	0.01 mg/m <sup>3</sup>
Chlorine:	0.01 mg/m <sup>3</sup>
Hydrogen chloride:	0.01 mg/m <sup>3</sup>
Hydrogen fluoride:	0.003 mg/m <sup>3</sup>
Ammonia:	0.3 mg/m <sup>3</sup>
Ozone:	0.01 mg/m <sup>3</sup>
Nitrogen oxides:	0.1 mg/m <sup>3</sup> (Expressed in equivalent values of Nitrogen dioxide.)

#### 2C2

Sea salts:	none
Sulphur dioxide:	0.1 mg/m <sup>3</sup>
Hydrogen sulphide:	0.01 mg/m <sup>3</sup>
Nitrogen oxides:	0.1 mg/m <sup>3</sup> (Expressed in the equivalent values of Nitrogen dioxide.)
Ozone:	0.01 mg/m <sup>3</sup>



Hydrogen chloride: 0.1 mg/m<sup>3</sup>  
Hydrogen fluoride: 0.003 mg/m<sup>3</sup>  
Ammonia: 0.3 mg/m<sup>3</sup>

#### 14.2.4 Mechanically active substances

1S2

Sand: 30 mg/m<sup>3</sup>  
Dust (suspension): 0.2 mg/m<sup>3</sup>  
Dust (sedimentation): 1.5 mg/(m<sup>2</sup>h)

2S1

Sand in air: No  
Dust (sedimentation): No

#### 14.2.5 Mechanical Conditions

1M2

Stationary vibration, sinusoidal

Please see section 14.1.

Non stationary vibration, including shock

Shock response spectrum type L  
peak acceleration: 40 m/s<sup>2</sup>

Static load: 5 kPa

2M2\*

Stationary vibration sinusoidal

Please see section 14.1.

Stationary vibration, random

Acceleration  
spectral density: 1 m<sup>2</sup>/s<sup>3</sup>  
Frequency range: 10 Hz to 200 Hz

and

Acceleration  
spectral density: 0.3 m<sup>2</sup>/s<sup>3</sup>  
Frequency range: 200 Hz to 2000 Hz

The later range can be neglected transporting with vehicles with high damping.

Non stationary vibration, including shock

Shock response spectrum type I.  
peak acceleration: 100 m/s<sup>2</sup>

and

Shock response spectrum type II.  
peak acceleration: 300 m/s<sup>2</sup>



\*Free fall: weight and drop height deviate from 2M2  
tested acc. to internal standard: F23047-A1004-S000-01-76

Specimen Weight [kg]	Drop Heights [mm]	
	Standard Level	Extra Level
up to 9,5 kg	460	760
over 9,5 to 18,6 kg	310	610
over 18,6 to 27,7 kg	200	460
over 27,7 kg	200	310
<b>Number of Drops</b>	<b>3</b>	<b>7</b>

Toppling                                      Around any of the edges.  
Rolling, pitching  
    Angle:                                     ±35°  
    Period:                                    8 s  
35° may occur for short time periods but 22.5° may persist permanently.  
Acceleration                                20 m/s<sup>2</sup>  
Static load:                                   10 kPa

## 15 Disclaimer

The information and recommendations in this document are based on standards and common engineering practices. Customer specific applications and specifications may require additional processes and tests that may supersede those recommended in this document.