

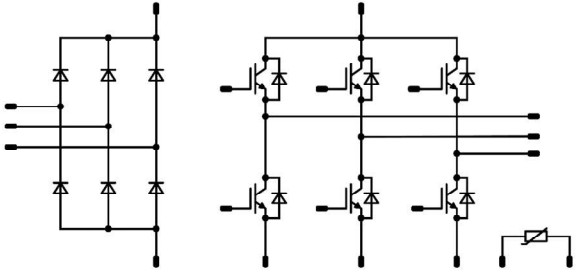

Vincotech

<i>flow PIM 0</i>	1200 V / 10 A
<div style="background-color: #eee; padding: 2px; margin-bottom: 5px;">Features</div> <ul style="list-style-type: none"> IGBT M7 with low V_{CEsat} and improved EMC behavior Open emitter configuration Compact and low inductive design Built-in NTC 	<div style="background-color: #eee; padding: 2px; margin-bottom: 5px;"><i>flow 0 12 mm housing</i></div> 
<div style="background-color: #eee; padding: 2px; margin-bottom: 5px;">Target applications</div> <ul style="list-style-type: none"> Industrial Drives 	<div style="background-color: #eee; padding: 2px; margin-bottom: 5px;">Schematic</div> 
<div style="background-color: #eee; padding: 2px; margin-bottom: 5px;">Types</div> <ul style="list-style-type: none"> 10-FZ12PNA010M7-P849C28 	

Maximum Ratings

$T_j = 25\text{ °C}$, unless otherwise specified

Parameter	Symbol	Condition	Value	Unit
Rectifier Diode				
Peak Repetitive Reverse Voltage	V_{RRM}		1600	V
Continuous (direct) forward current	I_F	$T_j = T_{jmax}$ $T_s = 80\text{ °C}$	33	A
Surge (non-repetitive) forward current	I_{FSM}	50 Hz Single Half Sine Wave $t_p = 10\text{ ms}$ $T_j = 150\text{ °C}$	200	A
Surge current capability	I^2t		200	A ² s
Total power dissipation	P_{tot}	$T_j = T_{jmax}$ $T_s = 80\text{ °C}$	44	W
Maximum Junction Temperature	T_{jmax}		150	°C



Vincotech

Maximum Ratings

$T_j = 25\text{ °C}$, unless otherwise specified

Parameter	Symbol	Condition	Value	Unit
Inverter Switch				
Collector-emitter voltage	V_{CES}		1200	V
Collector current	I_C	$T_j = T_{jmax}$ $T_s = 80\text{ °C}$	14	A
Repetitive peak collector current	I_{CRM}	t_p limited by T_{jmax}	20	A
Total power dissipation	P_{tot}	$T_j = T_{jmax}$ $T_s = 80\text{ °C}$	55	W
Gate-emitter voltage	V_{GES}		± 20	V
Maximum junction temperature	T_{jmax}		175	°C

Inverter Diode				
Peak repetitive reverse voltage	V_{RRM}		1200	V
Continuous (direct) forward current	I_F	$T_j = T_{jmax}$ $T_s = 80\text{ °C}$	19	A
Repetitive peak forward current	I_{FRM}	T_j limited by T_{jmax}	20	A
Total power dissipation	P_{tot}	$T_j = T_{jmax}$ $T_s = 80\text{ °C}$	50	W
Maximum junction temperature	T_{jmax}		175	°C

Module Properties

Thermal Properties				
Storage temperature	T_{stg}		-40...+125	°C
Operation temperature under switching condition	T_{jop}		-40...($T_{jmax} - 25$)	°C

Isolation Properties				
Isolation voltage	V_{isol}	DC Test Voltage* $t_p = 2\text{ s}$	6000	V
		AC Voltage $t_p = 1\text{ min}$	2500	V
Creepage distance			min. 12,7	mm
Clearance			9,29	mm
Comparative Tracking Index	CTI		> 200	

*100 % tested in production



Vincotech

Characteristic Values

Parameter	Symbol	Conditions					Value			Unit
		V_{GE} [V] V_{GS} [V]	V_{CE} [V] V_{DS} [V] V_F [V]	I_C [A] I_D [A] I_F [A]	T_j [°C]	Min	Typ	Max		

Rectifier Diode

Static

Forward voltage	V_F			30	25 125		1,22 1,21	1,8	V
Reverse leakage current	I_r		1600		25 145			50 1100	μ A

Thermal

Thermal resistance junction to sink	$R_{th(j-s)}$	$\lambda_{paste} = 3,4$ W/mK (PSX)					1,59		K/W
-------------------------------------	---------------	---------------------------------------	--	--	--	--	------	--	-----



Vincotech

Characteristic Values

Parameter	Symbol	Conditions					Value			Unit
		V_{GS} [V]	V_{GE} [V]	V_{DS} [V]	I_D [A]	T_j [°C]	Min	Typ	Max	

Inverter Switch

Static

Parameter	Symbol	$V_{GE} = V_{CE}$	V_{GS} [V]	V_{GE} [V]	I_D [A]	T_j [°C]	Min	Typ	Max	Unit
Gate-emitter threshold voltage	$V_{GE(th)}$				0,001	25	5,4	6	6,6	V
Collector-emitter saturation voltage	V_{CEsat}		15		10	25 125 150		1,66 1,90 1,96	1,95	V
Collector-emitter cut-off current	I_{CES}		0	1200		25			55	μA
Gate-emitter leakage current	I_{GES}		20	0		25			500	nA
Internal gate resistance	r_g							none		Ω
Input capacitance	C_{ies}							2000		pF
Output capacitance	C_{oes}		0	10		25		86		
Reverse transfer capacitance	C_{res}							23		
Gate charge	Q_g		15	600	10	25		80		nC

Thermal

Parameter	Symbol	$\lambda_{paste} = 3,4$ W/mK (PSX)	V_{GS} [V]	V_{GE} [V]	I_D [A]	T_j [°C]	Min	Typ	Max	Unit
Thermal resistance junction to sink	$R_{th(j-s)}$							1,72		K/W

Dynamic

Parameter	Symbol	$R_{goff} = 32$ Ω $R_{gon} = 32$ Ω	V_{GS} [V]	V_{GE} [V]	I_D [A]	T_j [°C]	Min	Typ	Max	Unit
Turn-on delay time	$t_{d(on)}$		±15	600	10	25		128		ns
Rise time	t_r					125		126		
						150		123		
						25		29		
Turn-off delay time	$t_{d(off)}$					125		32		
		150		34						
		25		145						
Fall time	t_f	125		179						
		150		182						
		25		98						
Turn-on energy (per pulse)	E_{on}	$Q_{tFWD} = 1,1$ μC $Q_{tFWD} = 1,7$ μC $Q_{tFWD} = 1,8$ μC				25		0,883		mWs
						125		1,125		
						150		1,189		
Turn-off energy (per pulse)	E_{off}					25		0,656		
						125		0,860		
						150		0,908		



Vincotech

Characteristic Values

Parameter	Symbol	Conditions					Value			Unit
		V_{GE} [V] V_{GS} [V]	V_{CE} [V] V_{DS} [V]	I_C [A] I_D [A]	I_C [A] I_F [A]	T_j [°C]	Min	Typ	Max	

Inverter Diode

Static

Forward voltage	V_F				10	25 125 150		1,61 1,69 1,69	2,1	V
Reverse leakage current	I_R			1200		25			25	μA

Thermal

Thermal resistance junction to sink	$R_{th(j-s)}$	$\lambda_{paste} = 3,4$ W/mK (PSX)						1,91		K/W
-------------------------------------	---------------	---------------------------------------	--	--	--	--	--	------	--	-----

Dynamic

Peak recovery current	I_{RRM}					25 125 150		9 9 9		A
Reverse recovery time	t_{rr}					25 125 150		254 373 409		ns
Recovered charge	Q_r	$di/dt = 278$ A/μs $di/dt = 270$ A/μs $di/dt = 272$ A/μs	±15	600	10	25 125 150		1,088 1,664 1,808		μC
Reverse recovered energy	E_{rec}					25 125 150		0,374 0,620 0,680		mWs
Peak rate of fall of recovery current	$(di_{rr}/dt)_{max}$					25 125 150		85 54 49		A/μs

Thermistor

Rated resistance	R					25		22		kΩ
Deviation of R_{100}	$\Delta_{R/R}$	$R_{100} = 1484$ Ω				100	-5		5	%
Power dissipation	P					25		5		mW
Power dissipation constant						25		1,5		mW/K
B-value	$B_{(25/50)}$	Tol. ±1 %				25		3962		K
B-value	$B_{(25/100)}$	Tol. ±1 %				25		4000		K
Vincotech NTC Reference									I	



Rectifier Diode Characteristics

figure 1. FWD
Typical forward characteristics

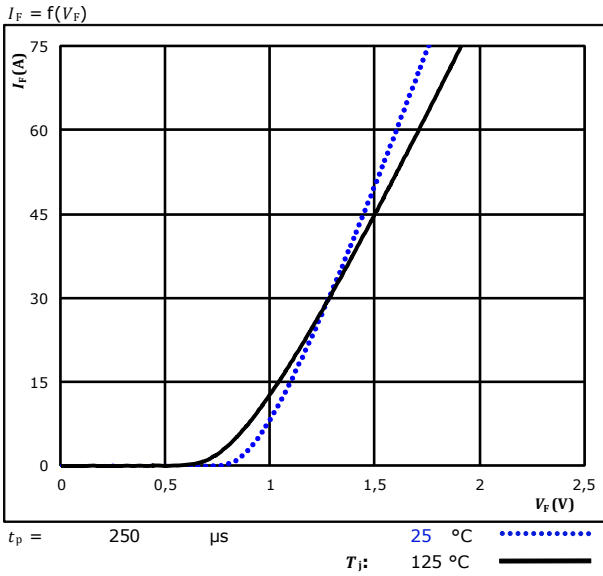
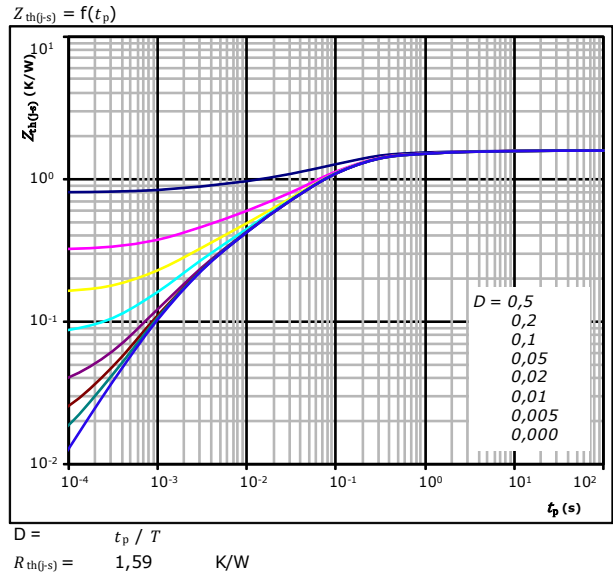

figure 2. FWD
Transient thermal impedance as a function of pulse width



Diode thermal model values

R (K/W)	τ (s)
3,44E-02	9,66E+00
1,12E-01	1,22E+00
5,81E-01	1,45E-01
4,89E-01	5,05E-02
2,38E-01	9,26E-03
1,22E-01	1,79E-03
1,22E-01	1,79E-03



Inverter Switch Characteristics

figure 1. IGBT

Typical output characteristics

$I_C = f(V_{CE})$

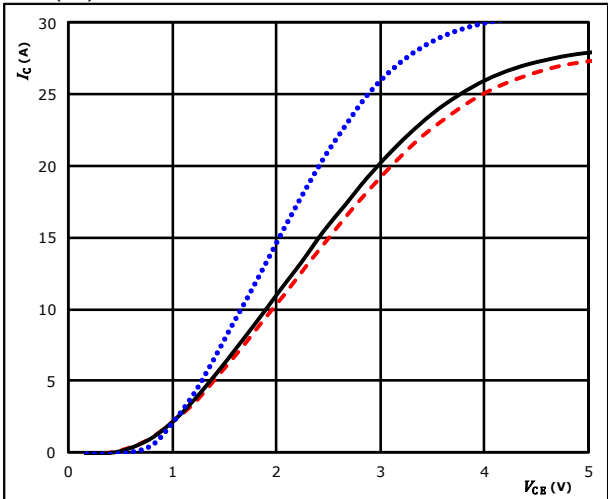

$t_p = 250 \mu s$ $T_j: 25 \text{ }^\circ C$ (dotted blue)
 $V_{GE} = 15 V$ $T_j: 125 \text{ }^\circ C$ (solid black)
 $T_j: 150 \text{ }^\circ C$ (dashed red)

figure 2. IGBT

Typical output characteristics

$I_C = f(V_{CE})$

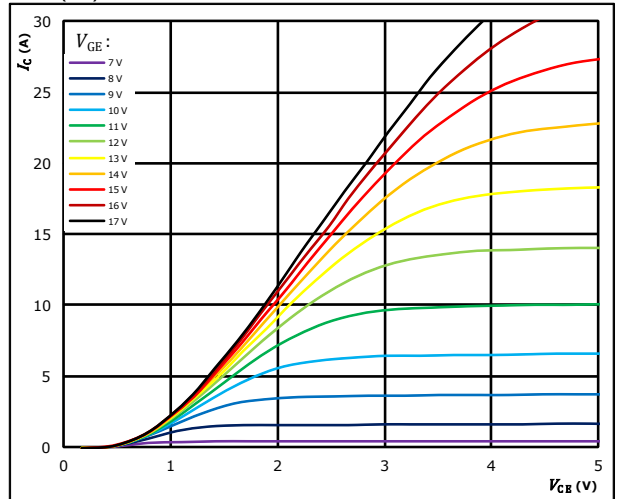

$t_p = 250 \mu s$ $T_j = 150 \text{ }^\circ C$
 V_{GE} from 7 V to 17 V in steps of 1 V

figure 3. IGBT

Typical transfer characteristics

$I_C = f(V_{GE})$

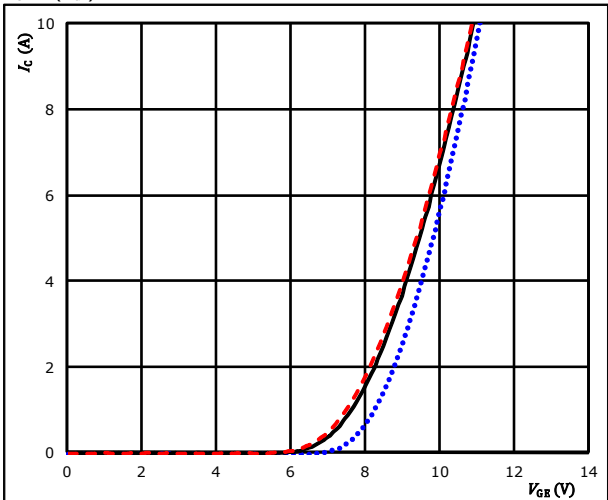

$t_p = 100 \mu s$ $T_j: 25 \text{ }^\circ C$ (dotted blue)
 $V_{CE} = 10 V$ $T_j: 125 \text{ }^\circ C$ (solid black)
 $T_j: 150 \text{ }^\circ C$ (dashed red)

figure 4. IGBT

Transient thermal impedance as function of pulse duration

$Z_{th(j-s)} = f(t_p)$

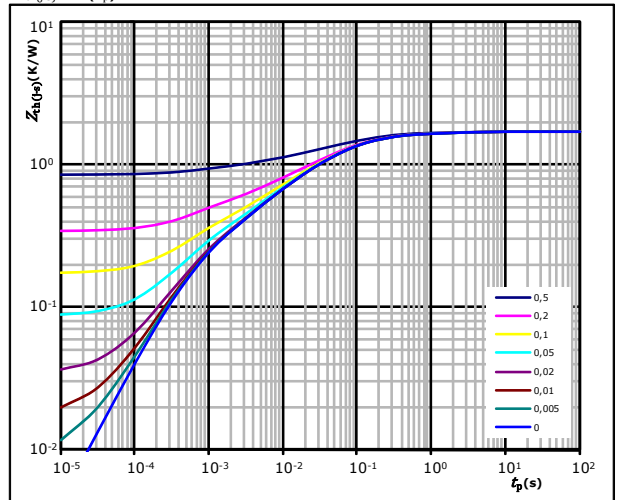

$D = t_p / T$
 $R_{th(j-s)} = 1,72 \text{ K/W}$

IGBT thermal model values

R (K/W)	τ (s)
8,08E-02	2,32E+00
2,21E-01	2,45E-01
6,51E-01	6,03E-02
3,93E-01	1,33E-02
1,95E-01	3,15E-03
1,82E-01	5,45E-04



Vincotech

Inverter Switch Characteristics

figure 5. IGBT

Safe operating area

$$I_C = f(V_{CE})$$

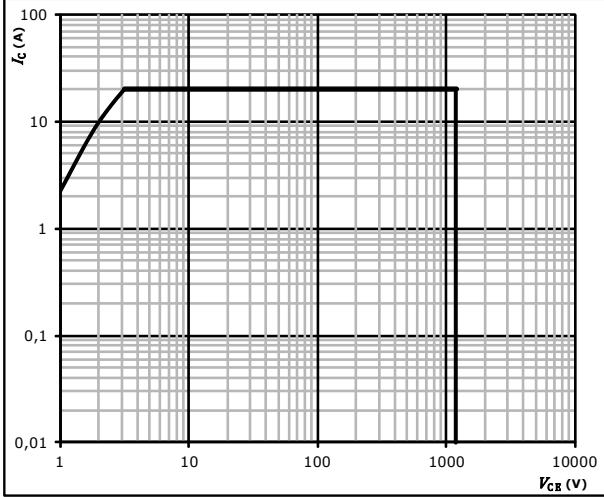

$D =$ single pulse
 $T_s =$ 80 °C
 $V_{GE} =$ ±15 V
 $T_j =$ T_{jmax}



Inverter Diode Characteristics

figure 1. FWD

Typical forward characteristics

$$I_F = f(V_F)$$

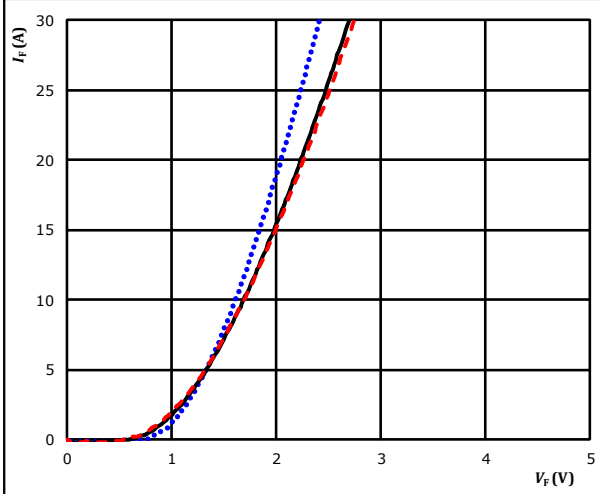

$t_p = 250 \mu s$
 T_j : 25 °C
 125 °C ———
 150 °C - - - -

figure 2. FWD

Transient thermal impedance as a function of pulse width

$$Z_{th(j-s)} = f(t_p)$$

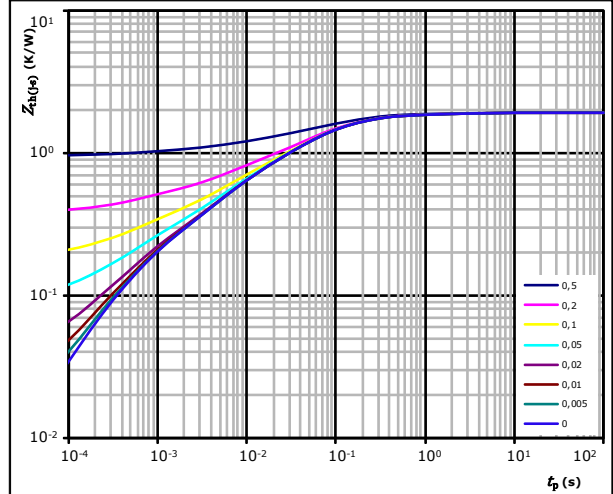

$D = t_p / T$
 $R_{th(j-s)} = 1,91 \text{ K/W}$
 FWD thermal model values

R (K/W)	τ (s)
9,38E-02	2,25E+00
3,43E-01	2,12E-01
8,53E-01	5,82E-02
3,59E-01	9,80E-03
1,37E-01	2,88E-03
1,26E-01	4,78E-04

Thermistor Characteristics

figure 1. Thermistor

Typical NTC characteristic as a function of temperature

$$R = f(T)$$

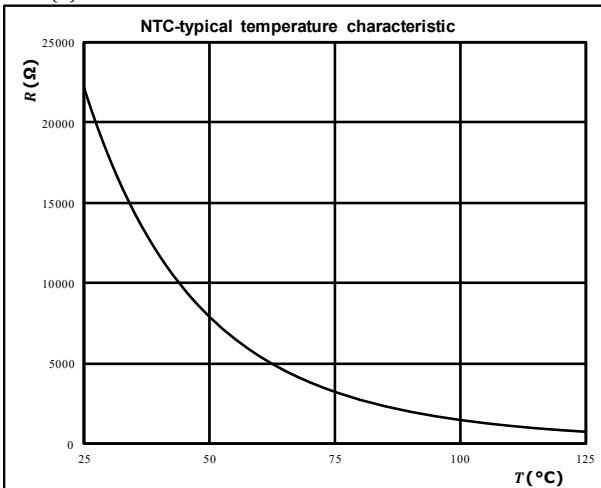



Inverter Switching Characteristics

figure 1. IGBT

Typical switching energy losses as a function of collector current

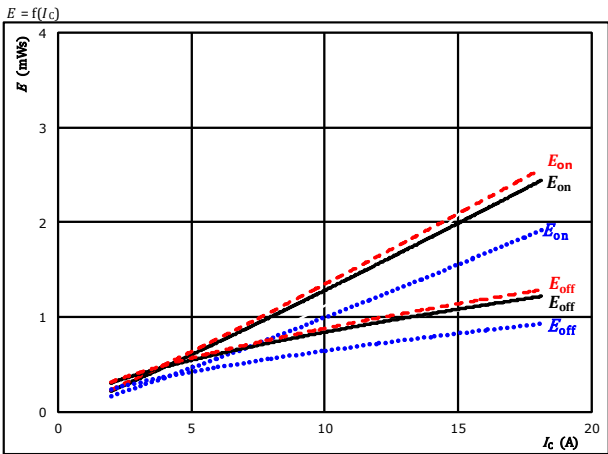

With an inductive load at
 $V_{CE} = 600$ V
 $V_{GE} = \pm 15$ V
 $R_{gon} = 32$ Ω
 $R_{goff} = 32$ Ω
 T_j : 25 °C (blue dotted), 125 °C (black solid), 150 °C (red dashed)

figure 2. IGBT

Typical switching energy losses as a function of gate resistor

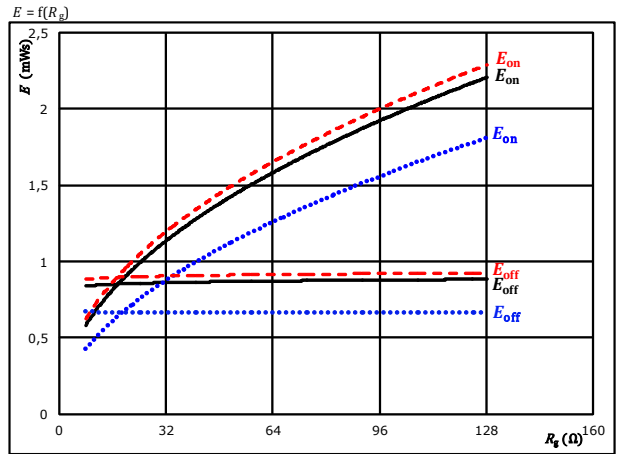

With an inductive load at
 $V_{CE} = 600$ V
 $V_{GE} = \pm 15$ V
 $I_C = 10$ A
 T_j : 25 °C (blue dotted), 125 °C (black solid), 150 °C (red dashed)

figure 3. FWD

Typical reverse recovered energy loss as a function of collector current

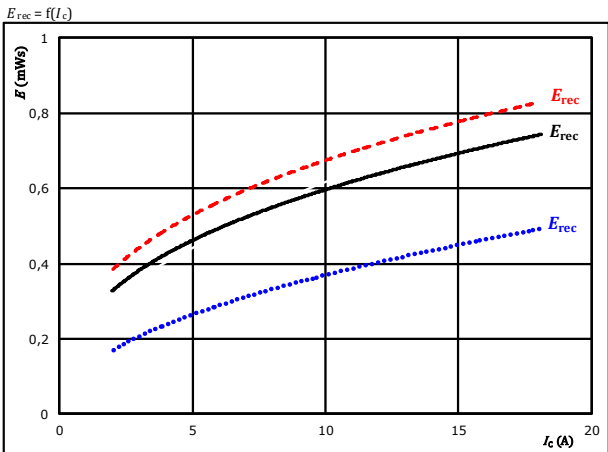

With an inductive load at
 $V_{CE} = 600$ V
 $V_{GE} = \pm 15$ V
 $R_{gon} = 32$ Ω
 T_j : 25 °C (blue dotted), 125 °C (black solid), 150 °C (red dashed)

figure 4. FWD

Typical reverse recovered energy loss as a function of gate resistor

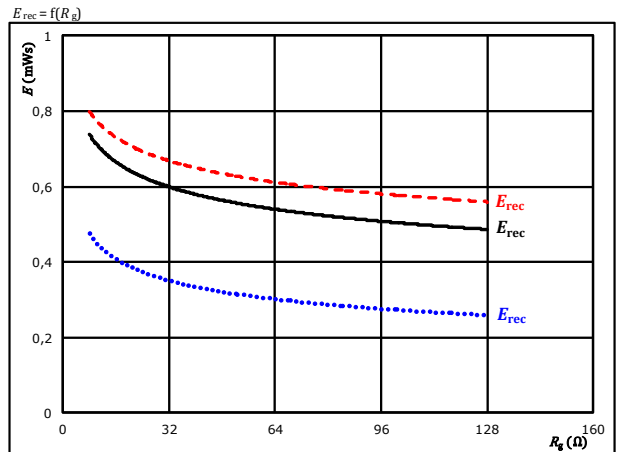

With an inductive load at
 $V_{CE} = 600$ V
 $V_{GE} = \pm 15$ V
 $I_C = 10$ A
 T_j : 25 °C (blue dotted), 125 °C (black solid), 150 °C (red dashed)



Inverter Switching Characteristics

figure 5. IGBT

Typical switching times as a function of collector current

$$t = f(I_c)$$

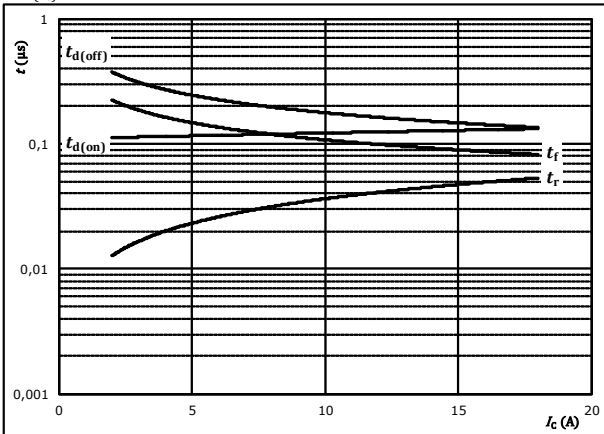

With an inductive load at

$T_j =$	150	°C
$V_{CE} =$	600	V
$V_{GE} =$	±15	V
$R_{gon} =$	32	Ω
$R_{goff} =$	32	Ω

figure 6. IGBT

Typical switching times as a function of gate resistor

$$t = f(R_g)$$

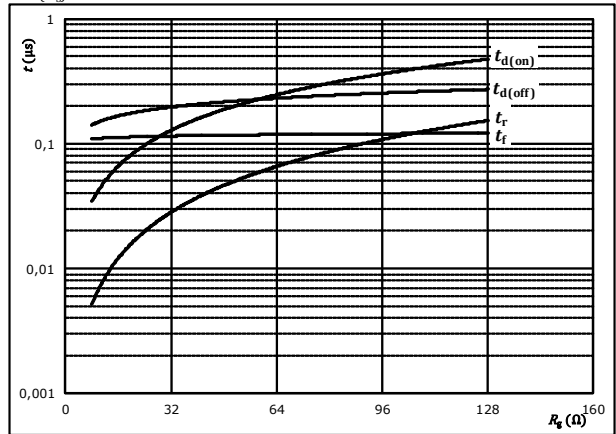

With an inductive load at

$T_j =$	150	°C
$V_{CE} =$	600	V
$V_{GE} =$	±15	V
$I_c =$	10	A

figure 7. FWD

Typical reverse recovery time as a function of collector current

$$t_{rr} = f(I_c)$$

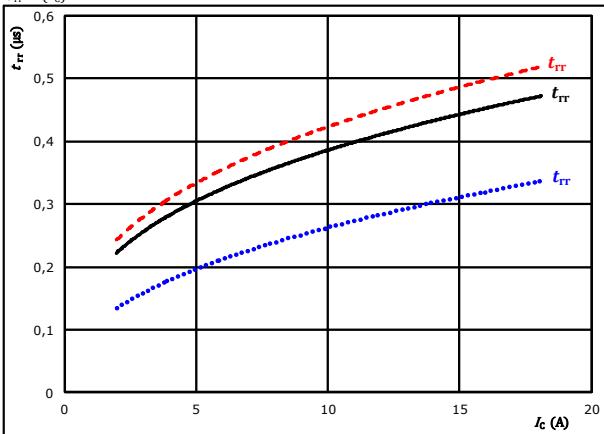

At	$V_{CE} =$	600	V	$T_j:$	25 °C
	$V_{GE} =$	±15	V		125 °C	————
	$R_{gon} =$	32	Ω		150 °C	-----

figure 8. FWD

Typical reverse recovery time as a function of IGBT turn on gate resistor

$$t_{rr} = f(R_{gon})$$

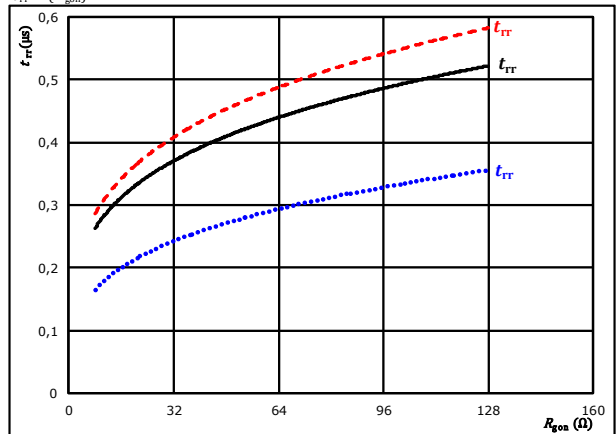

At	$V_{CE} =$	600	V	$T_j:$	25 °C
	$V_{GE} =$	±15	V		125 °C	————
	$I_c =$	10	A		150 °C	-----



Inverter Switching Characteristics

figure 9. FWD

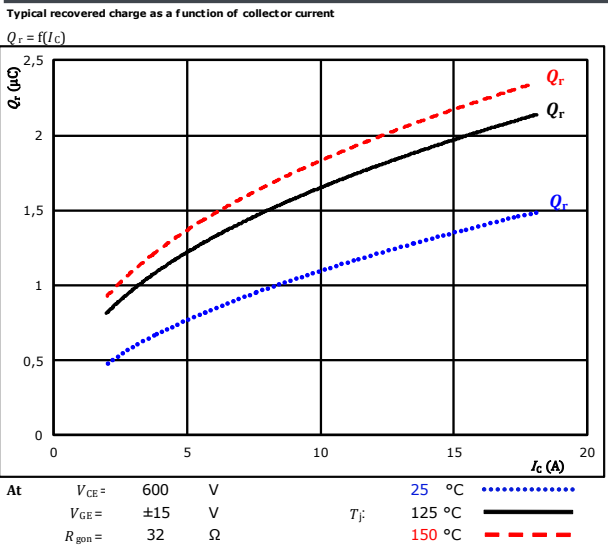

figure 10. FWD

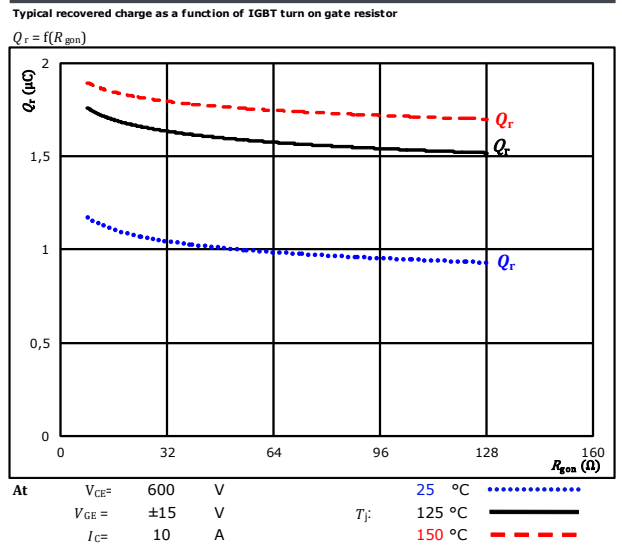

figure 11. FWD

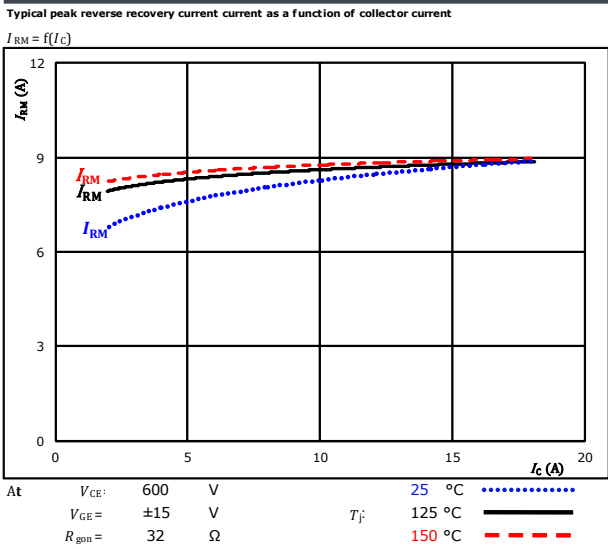
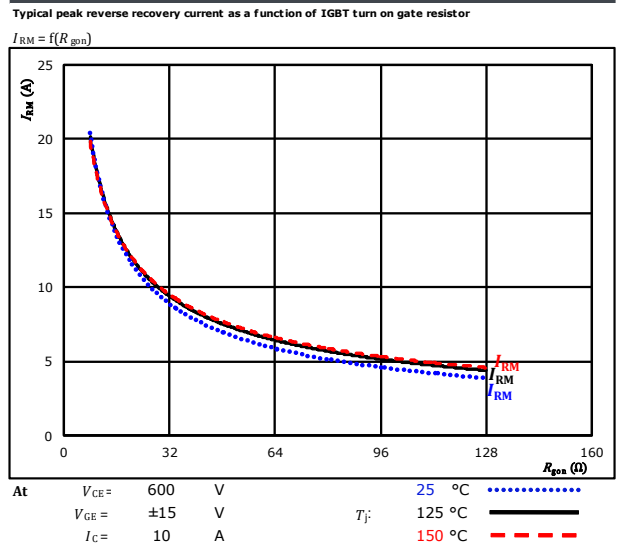

figure 12. FWD





Inverter Switching Characteristics

figure 13. FWD

Typical rate of fall of forward and reverse recovery current as a function of collector current
 $di_f/dt, di_{rr}/dt = f(I_c)$

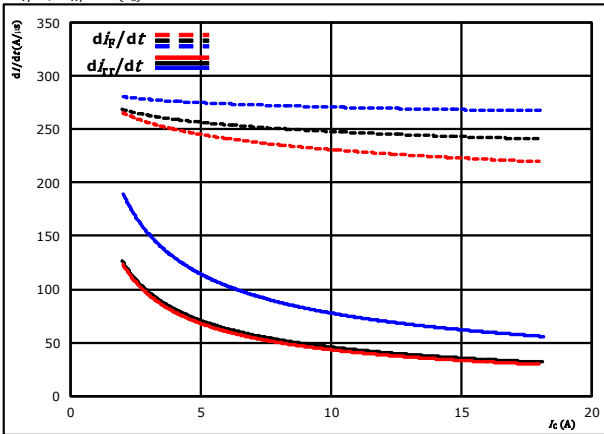

At $V_{CE} = 600$ V $T_j = 25$ °C $\dots\dots\dots$
 $V_{GE} = \pm 15$ V $T_j = 125$ °C ---
 $R_{g0n} = 32$ Ω $T_j = 150$ °C ---

figure 14. FWD

Typical rate of fall of forward and reverse recovery current as a function of IGBT turn on gate resistor
 $di_f/dt, di_{rr}/dt = f(R_{g0n})$

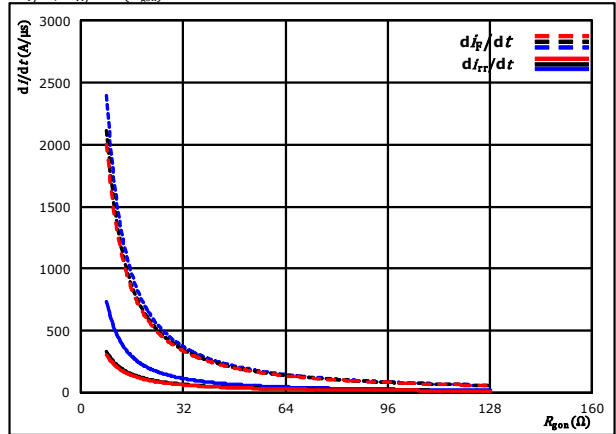

At $V_{CE} = 600$ V $T_j = 25$ °C $\dots\dots\dots$
 $V_{GE} = \pm 15$ V $T_j = 125$ °C ---
 $I_c = 10$ A $T_j = 150$ °C ---

figure 15. IGBT

Reverse bias safe operating area
 $I_c = f(V_{CB})$

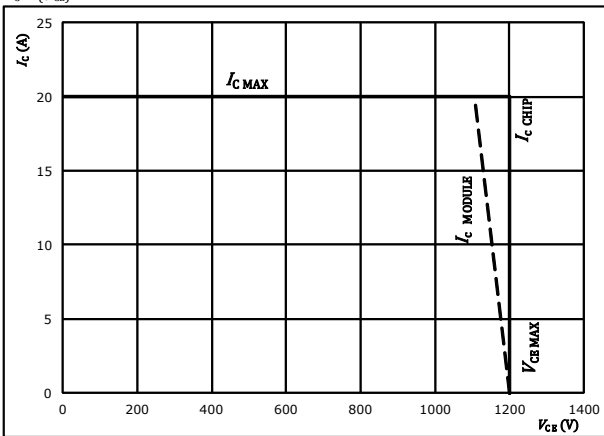

At $T_j = 175$ °C
 $R_{g0n} = 32$ Ω
 $R_{g0ff} = 32$ Ω



Inverter Switching Definitions

General conditions

T_j	=	125 °C
R_{gon}	=	32 Ω
R_{goff}	=	32 Ω

figure 1. IGBT

Turn-off Switching Waveforms & definition of t_{doff} , t_{Eoff} (t_{Eoff} = integrating time for E_{off})

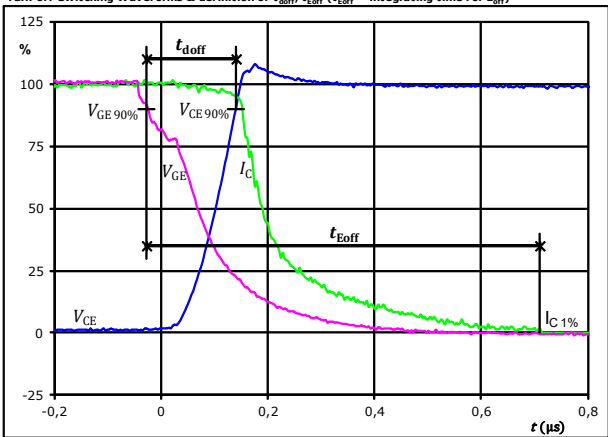

$V_{CE}(0\%) =$	-15	V
$V_{GE}(100\%) =$	15	V
$V_C(100\%) =$	600	V
$I_C(100\%) =$	10	A
$t_{doff} =$	0,179	μs
$t_{Eoff} =$	0,737	μs

figure 2. IGBT

Turn-on Switching Waveforms & definition of t_{don} , t_{Eon} (t_{Eon} = integrating time for E_{on})

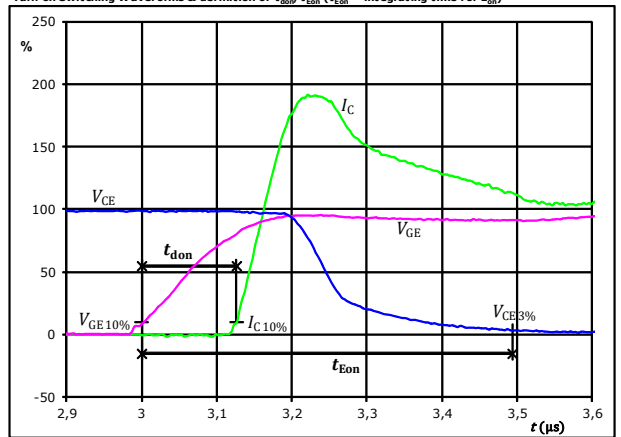

$V_{CE}(0\%) =$	-15	V
$V_{GE}(100\%) =$	15	V
$V_C(100\%) =$	600	V
$I_C(100\%) =$	10	A
$t_{don} =$	0,126	μs
$t_{Eon} =$	0,493	μs

figure 3. IGBT

Turn-off Switching Waveforms & definition of t_f

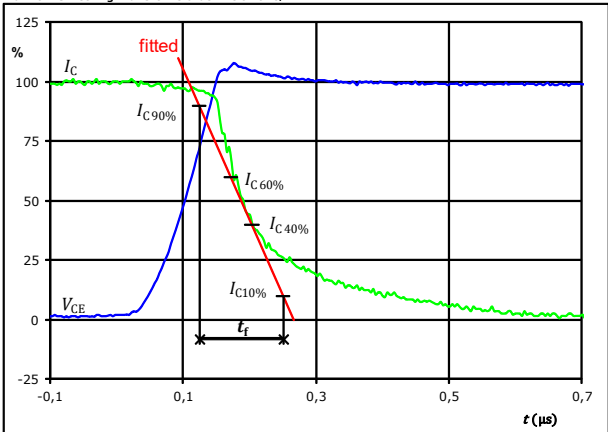

$V_C(100\%) =$	600	V
$I_C(100\%) =$	10	A
$t_f =$	0,108	μs

figure 4. IGBT

Turn-on Switching Waveforms & definition of t_r

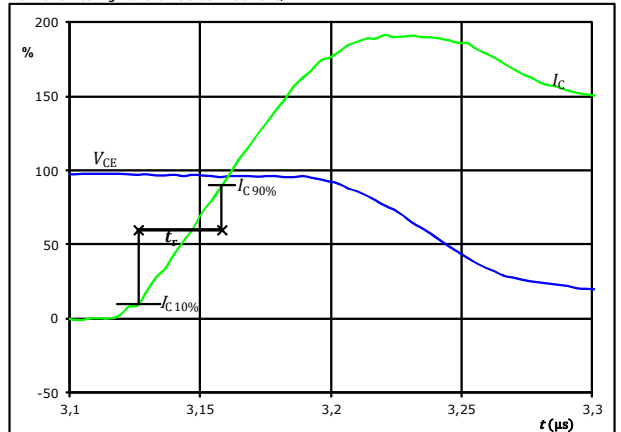

$V_C(100\%) =$	600	V
$I_C(100\%) =$	10	A
$t_r =$	0,032	μs



Inverter Switching Characteristics

figure 5. IGBT

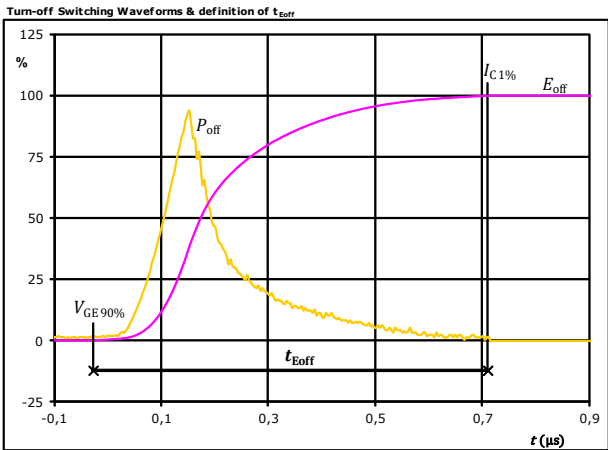

$P_{off}(100\%) = 6,02$ kW
 $E_{off}(100\%) = 0,86$ mJ
 $t_{Eoff} = 0,74$ μs

figure 6. IGBT

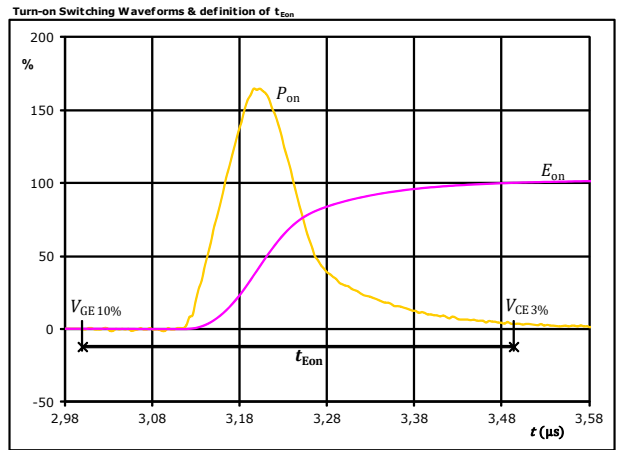

$P_{on}(100\%) = 6,02$ kW
 $E_{on}(100\%) = 1,13$ mJ
 $t_{Eon} = 0,49$ μs

figure 7. FWD

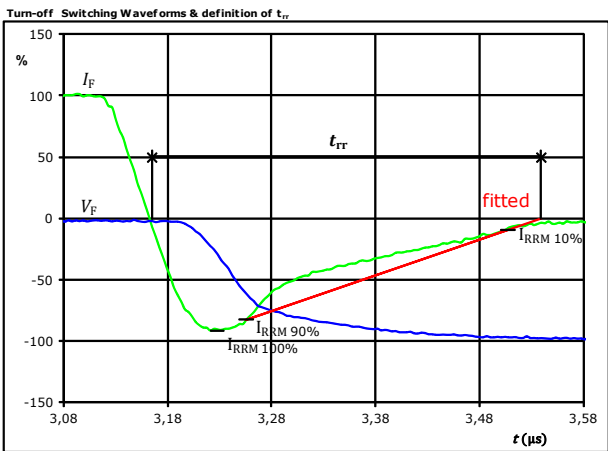

$V_F(100\%) = 600$ V
 $I_F(100\%) = 10$ A
 $I_{RRM}(100\%) = -9$ A
 $t_{rr} = 0,373$ μs



Inverter Switching Characteristics

figure 8. FWD

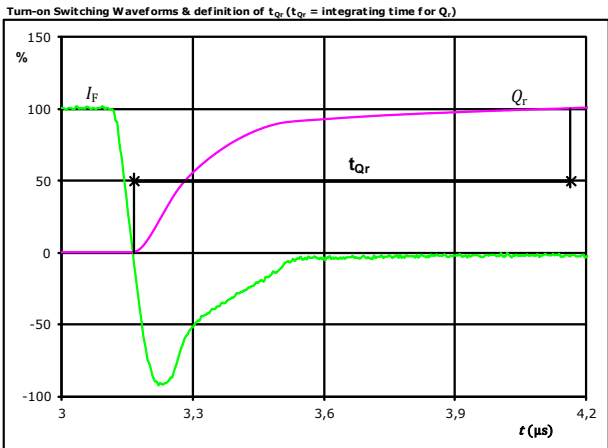

$I_F(100\%) =$	10	A
$Q_r(100\%) =$	1,66	μC
$t_{Qr} =$	1,00	μs

figure 9. FWD

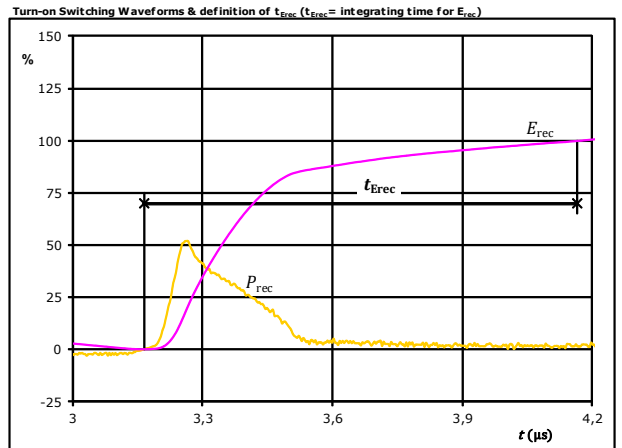

$P_{rec}(100\%) =$	6,02	kW
$E_{rec}(100\%) =$	0,62	mJ
$t_{Erec} =$	1,00	μs



Vincotech

Ordering Code & Marking						
Version			Ordering Code			
without thermal paste 12 mm housing with solder pins			10-FZ12PNA010M7-P849C28			
with thermal paste 12 mm housing with solder pins			10-FZ12PNA010M7-P849C28-/3/			
NN-NNNNNNNNNNNN TTTTIV WWYY UL VIN LLLL SSSS						
Text	Name		Date code	UL & VIN	Lot	Serial
	NN-NNNNNNNNNNNN-TTTTIV		WWYY	UL VIN	LLLL	SSSS
	Datamatrix	Type&Ver	Lot number	Serial	Date code	
	TTTTIV	LLLL	SSSS	WWYY		

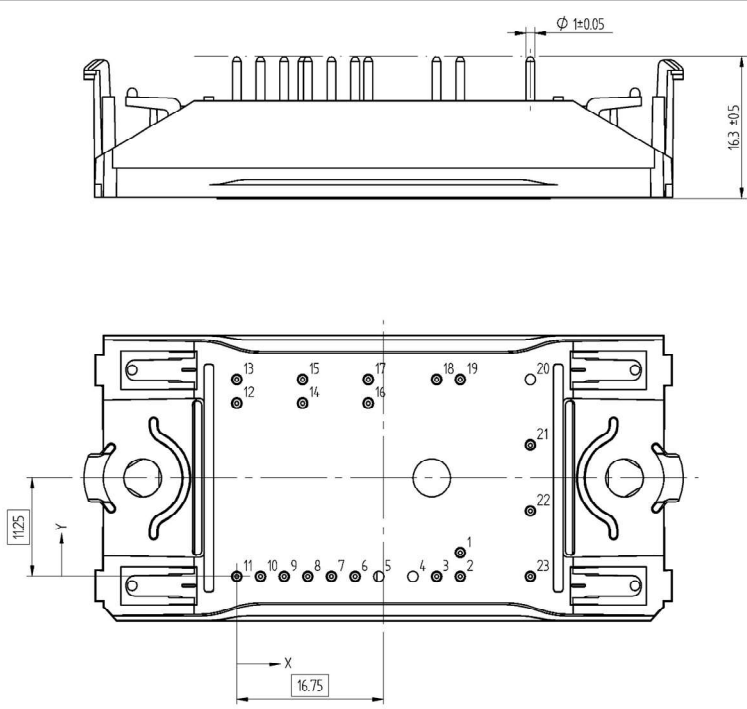
Pin table				Outline	
Pin	X	Y	Function		
1	25,5	2,7	Therm1		
2	25,5	0	Therm2		
3	22,8	0	DC-Rect		
4	Not assembled				
5	Not assembled				
6	13,5	0	G15		
7	10,8	0	DC-3		
8	8,1	0	G13		
9	5,4	0	DC-2		
10	2,7	0	G11		
11	0	0	DC-1		
12	0	19,8	G12		
13	0	22,5	Ph1		
14	7,5	19,8	G14		
15	7,5	22,5	Ph2		
16	15	19,8	G16		
17	15	22,5	Ph3		
18	22,8	22,5	DC+Inv		
19	25,5	22,5	DC+Rect		
20	Not assembled				
21	33,5	15	ACIn1		
22	33,5	7,5	ACIn2		
23	33,5	0	ACIn3		

Tolerance of pinpositions: ±0.5mm at the end of pins
Dimension of coordinate axis is only offset without tolerance



Vincotech

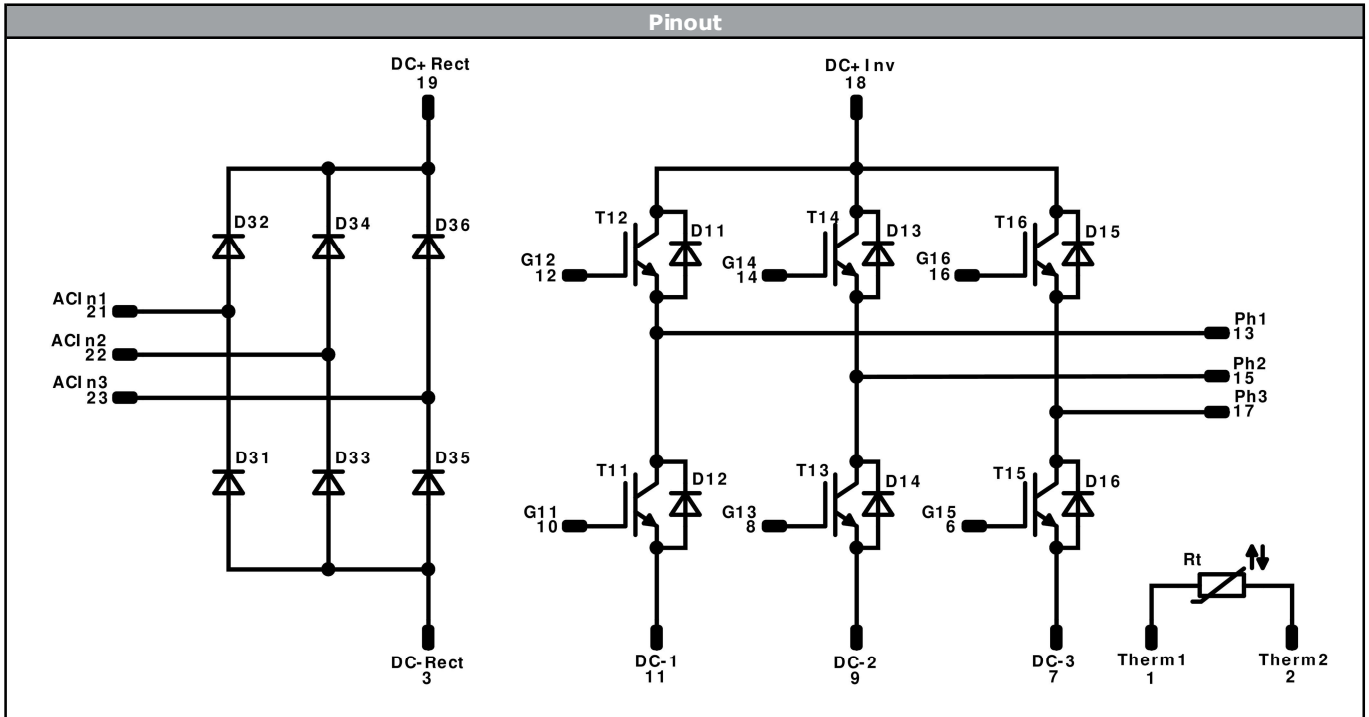

Identification					
ID	Component	Voltage	Current	Function	Comment
D31, D32, D33, D34, D35, D36	Rectifier Diode	1600 V	25 A	Rectifier Diode	
T11, T12, T13, T14, T15, T16	IGBT	1200 V	10 A	Inverter Switch	
D11, D12, D13, D14, D15, D16	FWD	1200 V	10 A	Inverter Diode	
Rt	NTC			Thermistor	



Vincotech

Packaging instruction			
Standard packaging quantity (SPQ) 135	>SPQ	Standard	<SPQ Sample

Handling instruction
Handling instructions for <i>flow 0</i> packages see vincotech.com website.

Package data
Package data for <i>flow 0</i> packages see vincotech.com website.

UL recognition and file number
This device is certified according to UL 1557 standard, UL file number E192116. For more information see vincotech.com website. 

Document No.:	Date:	Modification:	Pages
10-FZ12PNA010M7-P849C28-D2-14	16 May. 2019	Correction of I _c /I _f values	1,2

DISCLAIMER

The information, specifications, procedures, methods and recommendations herein (together "information") are presented by Vincotech to reader in good faith, are believed to be accurate and reliable, but may well be incomplete and/or not applicable to all conditions or situations that may exist or occur. Vincotech reserves the right to make any changes without further notice to any products to improve reliability, function or design. No representation, guarantee or warranty is made to reader as to the accuracy, reliability or completeness of said information or that the application or use of any of the same will avoid hazards, accidents, losses, damages or injury of any kind to persons or property or that the same will not infringe third parties rights or give desired results. It is reader's sole responsibility to test and determine the suitability of the information and the product for reader's intended use.

LIFE SUPPORT POLICY

Vincotech products are not authorised for use as critical components in life support devices or systems without the express written approval of Vincotech.

As used herein:

1. Life support devices or systems are devices or systems which, (a) are intended for surgical implant into the body, or (b) support or sustain life, or (c) whose failure to perform when properly used in accordance with instructions for use provided in labelling can be reasonably expected to result in significant injury to the user.
2. A critical component is any component of a life support device or system whose failure to perform can be reasonably expected to cause the failure of the life support device or system, or to affect its safety or effectiveness.