

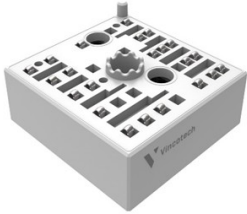
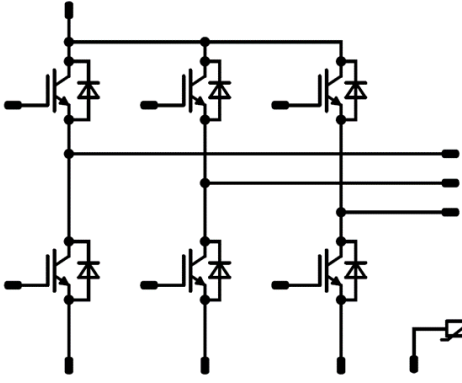

Vincotech

MiniSKiiP PACK 1	1200 V / 15 A
<div style="border: 1px solid black; padding: 5px; margin-bottom: 10px;"> <p style="text-align: center; background-color: #cccccc; margin: 0;">Features</p> <ul style="list-style-type: none"> Solderless interconnection Trench Fieldstop IGBT4 technology </div> <div style="border: 1px solid black; padding: 5px; margin-bottom: 10px;"> <p style="text-align: center; background-color: #cccccc; margin: 0;">Target applications</p> <ul style="list-style-type: none"> Servo Drives Industrial Motor Drives UPS </div> <div style="border: 1px solid black; padding: 5px;"> <p style="text-align: center; background-color: #cccccc; margin: 0;">Types</p> <ul style="list-style-type: none"> V23990-K219-F40-PM </div>	<div style="border: 1px solid black; padding: 5px; margin-bottom: 10px;"> <p style="text-align: center; background-color: #cccccc; margin: 0;">MiniSKiiP 1 housing</p>  </div> <div style="border: 1px solid black; padding: 5px;"> <p style="text-align: center; background-color: #cccccc; margin: 0;">Schematic</p>  </div>

Maximum Ratings

$T_j = 25\text{ °C}$, unless otherwise specified

Parameter	Symbol	Condition	Value	Unit
Inverter Switch				
Collector-emitter voltage	V_{CES}		1200	V
Collector current	I_C		20	A
Repetitive peak collector current	I_{CRM}	t_p limited by T_{jmax}	45	A
Turn off safe operating area		$V_{CE} \leq 1200\text{ V}$, $T_j \leq T_{opmax}$	30	A
Total power dissipation	P_{tot}	$T_j = T_{jmax}$ $T_s = 80\text{ °C}$	88	W
Gate-emitter voltage	V_{GES}		±20	V
Short circuit ratings	t_{SC}	$V_{GE} = 15\text{ V}$ $V_{CE} = 800\text{ V}$ $T_j = 150\text{ °C}$	10	µs
Maximum junction temperature	T_{jmax}		175	°C



Vincotech

Maximum Ratings

$T_j = 25\text{ °C}$, unless otherwise specified

Parameter	Symbol	Condition	Value	Unit
Inverter Diode				
Peak repetitive reverse voltage	V_{RRM}		1200	V
Continuous (direct) forward current	I_F		15	A
Repetitive peak forward current	I_{FRM}	t_p limited by T_{jmax}	45	A
Total power dissipation	P_{tot}	$T_j = T_{jmax}$ $T_s = 80\text{ °C}$	66	W
Maximum junction temperature	T_{jmax}		175	°C

Module Properties

Thermal Properties

Storage temperature	T_{stg}		-40...+125	°C
Operation temperature under switching condition	T_{top}		-40...($T_{jmax} - 25$)	°C

Isolation Properties

Isolation voltage	V_{isol}	DC Test Voltage* $t_p = 2\text{ s}$	5500	V
		AC Voltage $t_p = 1\text{ min}$	2500	V
Creepage distance		With std lid For more informations see handling instructions	6,3	mm
Clearance		With std lid For more informations see handling instructions	6,3	mm
Comparative Tracking Index	CTI		> 200	

*100 % tested in production



Characteristic Values

Parameter	Symbol	Conditions					Value			Unit
		V_{GS} [V]	V_{GE} [V]	V_{DS} [V]	I_D [A]	T_j [°C]	Min	Typ	Max	

Inverter Switch

Static

Parameter	Symbol	Conditions	V_{GS} [V]	V_{GE} [V]	V_{DS} [V]	I_D [A]	T_j [°C]	Min	Typ	Max	Unit
Gate-emitter threshold voltage	$V_{GE(th)}$	$V_{GE} = V_{CE}$				0,0005	25	5	5,8	6,5	V
Collector-emitter saturation voltage	V_{CEsat}		15			15	25 150	1,6	2,1 2,39	2,15	V
Collector-emitter cut-off current	I_{CES}		0	1200			25			60	μA
Gate-emitter leakage current	I_{GES}		20	0			25			200	nA
Internal gate resistance	r_g								none		Ω
Input capacitance	C_{ies}	$f = 1$ Mhz	0	25			25		900		pF
Output capacitance	C_{oes}								80		
Reverse transfer capacitance	C_{res}								55		
Gate charge	Q_g		±15				25		120		nC

Thermal

Parameter	Symbol	Conditions	V_{GS} [V]	V_{GE} [V]	V_{DS} [V]	I_D [A]	T_j [°C]	Min	Typ	Max	Unit
Thermal resistance junction to sink	$R_{th(j-s)}$	$\lambda_{paste} = 2,5$ W/mK (HPTP)							1,08		K/W

Dynamic

Parameter	Symbol	Conditions	V_{GS} [V]	V_{GE} [V]	V_{DS} [V]	I_D [A]	T_j [°C]	Min	Typ	Max	Unit
Turn-on delay time	$t_{d(on)}$	$R_{gon} = 32$ Ω $R_{goff} = 32$ Ω	±15	600	15		25 150		97 98		ns
Rise time	t_r								30 35		
Turn-off delay time	$t_{d(off)}$								216 288		
Fall time	t_f								91 134		
Turn-on energy (per pulse)	E_{on}							$Q_{tFWD} = 1$ μC		1 1,52	
Turn-off energy (per pulse)	E_{off}	$Q_{tFWD} = 2,4$ μC		0,9 1,48							



Vincotech

Characteristic Values

Parameter	Symbol	Conditions					Value			Unit
		V_{GE} [V] V_{GS} [V]	V_{CE} [V] V_{DS} [V] V_F [V]	I_C [A] I_D [A] I_F [A]	T_j [°C]	Min	Typ	Max		

Inverter Diode

Static

Forward voltage	V_F				15	25 150	1,3	2,56 2,51	2,8	V
-----------------	-------	--	--	--	----	-----------	-----	--------------	-----	---

Thermal

Thermal resistance junction to sink	$R_{th(j-s)}$	$\lambda_{paste} = 2,5$ W/mK (HPTP)						1,44		K/W
-------------------------------------	---------------	--	--	--	--	--	--	------	--	-----

Dynamic

Peak recovery current	I_{RRM}	$di/dt = 392$ A/ μ s $di/dt = 390$ A/ μ s	± 15	600	15	25		8,13		A
Reverse recovery time	t_{rr}					150		11,5		
						25		289		
Recovered charge	Q_r					150		536		
						25		0,98		
Reverse recovered energy	E_{rec}					150		2,38		
		25		0,37						
Peak rate of fall of recovery current	$(di_{rr}/dt)_{max}$	150		71						
		25		54						

Thermistor

Rated resistance	R					25		1		k Ω
Deviation of R_{100}	$\Delta_{R/R}$	$R_{100} = 1670$ Ω				100	-2		+2	%
R_{100}	R					100		1670		Ω
Power dissipation constant						25		0,76		mW/K
A-value	$A_{(25/50)}$					25		$7,635 \cdot 10^{-3}$		1/K
B-value	$B_{(25/100)}$					25		$1,731 \cdot 10^{-5}$		1/K ²
Vincotech PTC Reference									E	



Inverter Switch Characteristics

figure 1. IGBT

Typical output characteristics

$$I_C = f(V_{CE})$$

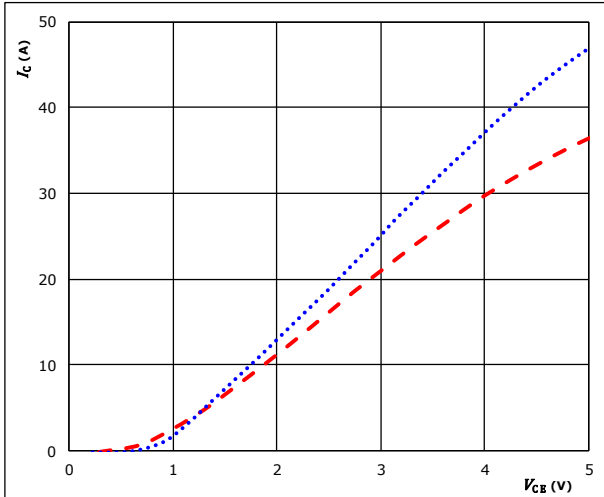

$t_p = 250 \mu\text{s}$
 $V_{GE} = 15 \text{ V}$
 $T_j: 25 \text{ }^\circ\text{C}$ (blue dotted line)
 $150 \text{ }^\circ\text{C}$ (red dashed line)

figure 2. IGBT

Typical output characteristics

$$I_C = f(V_{CE})$$

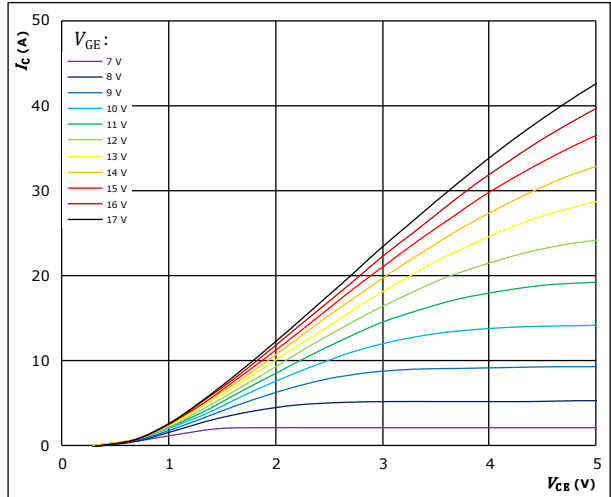

$t_p = 250 \mu\text{s}$
 $T_j = 150 \text{ }^\circ\text{C}$
 V_{GE} from 7 V to 17 V in steps of 1 V

figure 3. IGBT

Typical transfer characteristics

$$I_C = f(V_{GE})$$

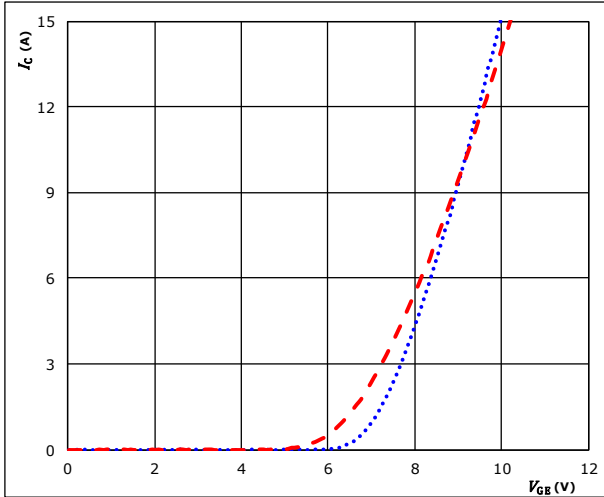

$t_p = 100 \mu\text{s}$
 $V_{CE} = 10 \text{ V}$
 $T_j: 25 \text{ }^\circ\text{C}$ (blue dotted line)
 $150 \text{ }^\circ\text{C}$ (red dashed line)

figure 4. IGBT

Transient thermal impedance as function of pulse duration

$$Z_{th(j-s)} = f(t_p)$$

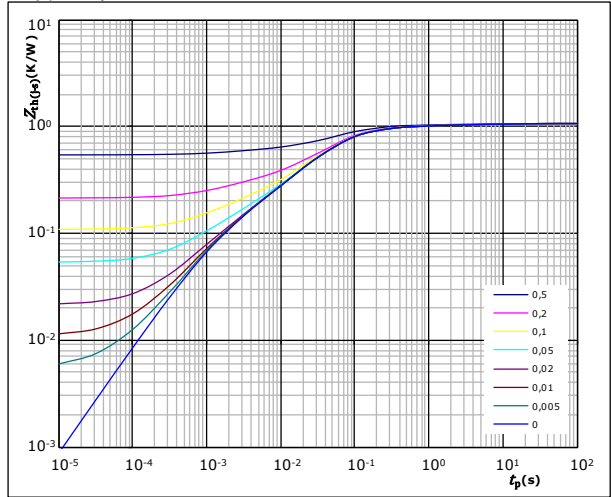

$D = t_p / T$
 $R_{th(j-s)} = 1,08 \text{ K/W}$

IGBT thermal model values

R (K/W)	τ (s)
4,02E-02	8,05E+00
7,53E-02	6,86E-01
2,00E-01	1,22E-01
5,79E-01	4,09E-02
1,08E-01	7,96E-03
7,24E-02	1,22E-03
4,99E-03	5,90E-04



Inverter Switch Characteristics

figure 5. IGBT

Gate voltage vs gate charge

$$V_{GE} = f(Q_G)$$

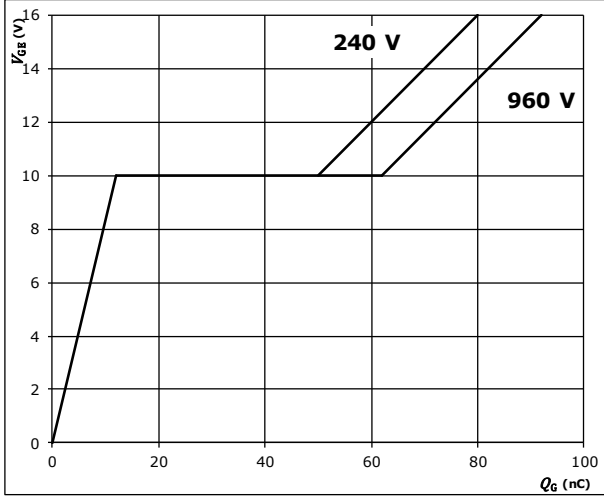

$I_C = 15$ A

figure 6. IGBT

Safe operating area

$$I_C = f(V_{CE})$$

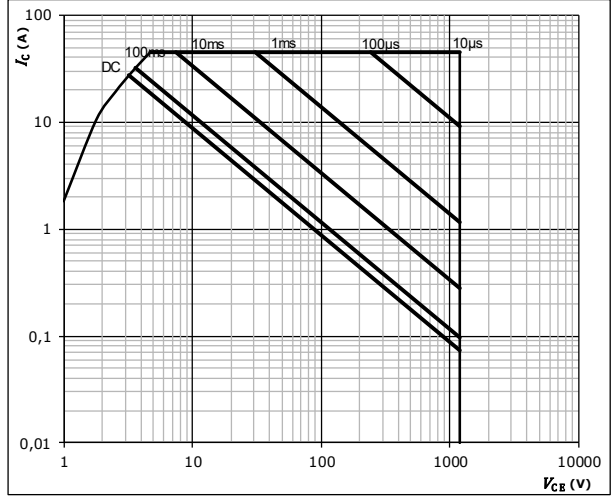

$D =$ single pulse
 $T_s = 80$ °C
 $V_{GE} = \pm 15$ V
 $T_j = T_{jmax}$



Inverter Diode Characteristics

figure 1. FWD

Typical forward characteristics

$$I_F = f(V_F)$$

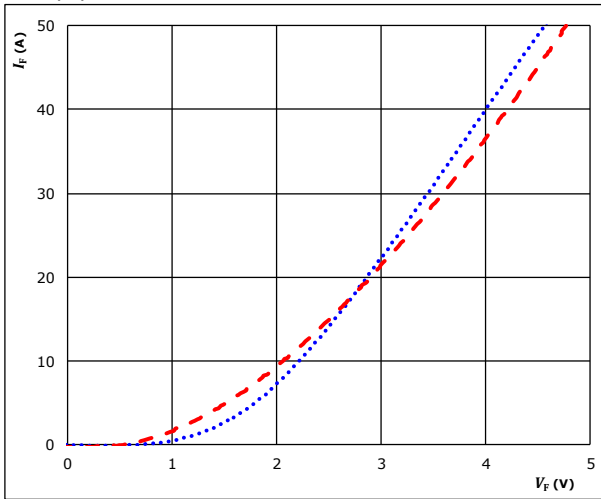

$t_p = 250 \mu s$
 T_j : 25 °C (blue dotted line), 150 °C (red dashed line)

figure 2. FWD

Transient thermal impedance as a function of pulse width

$$Z_{th(j-s)} = f(t_p)$$

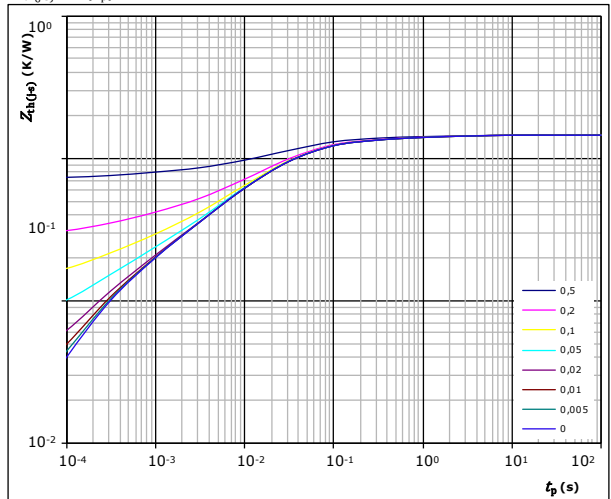

$D = t_p / T$
 $R_{th(j-s)} = 1,44 \text{ K/W}$
FWD thermal model values

$R \text{ (K/W)}$	$\tau \text{ (s)}$
6,32E-02	2,64E+00
1,25E-01	3,53E-01
4,72E-01	5,08E-02
4,73E-01	1,56E-02
2,06E-01	2,93E-03
1,06E-01	3,09E-04

Thermistor Characteristics

figure 1. Thermistor

Typical PTC characteristic
as a function of temperature

$$R = f(T)$$

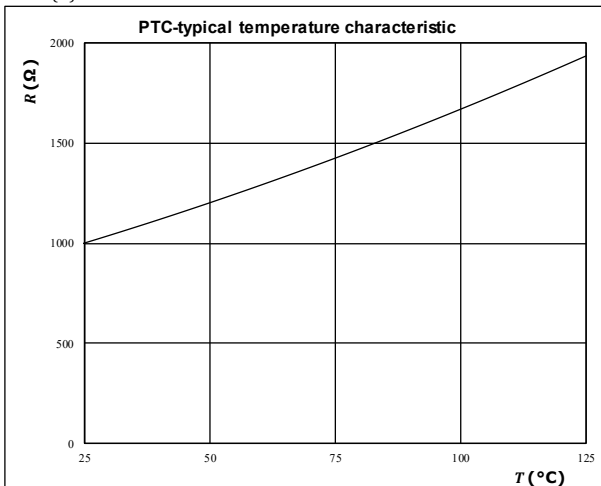



Inverter Switching Characteristics

figure 1. IGBT

Typical switching energy losses as a function of collector current

$$E = f(I_c)$$

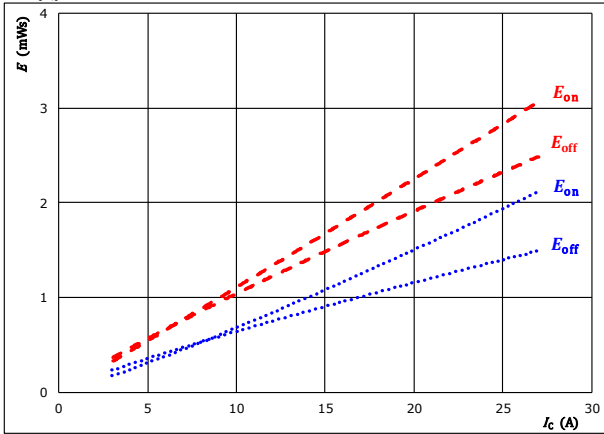

With an inductive load at

$V_{CE} = 600$ V
 $V_{GE} = \pm 15$ V
 $R_{gon} = 32$ Ω
 $R_{goff} = 32$ Ω

T_j :

25 °C (dotted blue)
150 °C (dashed red)

figure 2. IGBT

Typical switching energy losses as a function of gate resistor

$$E = f(R_g)$$

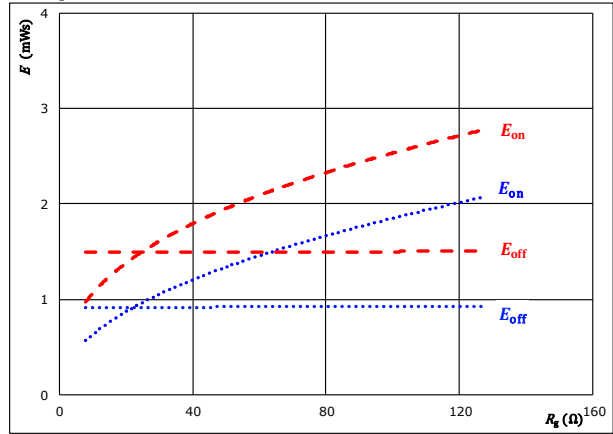

With an inductive load at

$V_{CE} = 600$ V
 $V_{GE} = \pm 15$ V
 $I_c = 15$ A

T_j :

25 °C (dotted blue)
150 °C (dashed red)

figure 3. FWD

Typical reverse recovered energy loss as a function of collector current

$$E_{rec} = f(I_c)$$

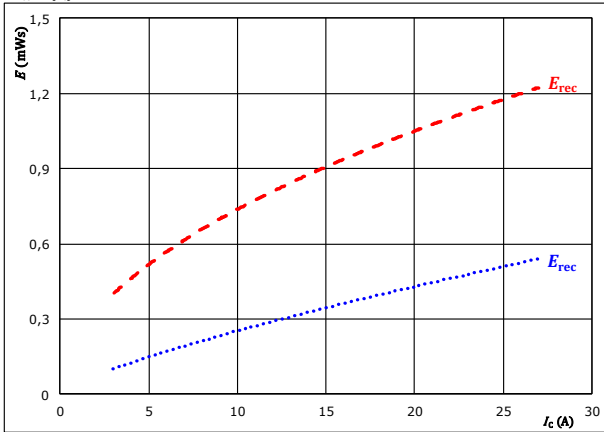

With an inductive load at

$V_{CE} = 600$ V
 $V_{GE} = \pm 15$ V
 $R_{gon} = 32$ Ω

T_j :

25 °C (dotted blue)
150 °C (dashed red)

figure 4. FWD

Typical reverse recovered energy loss as a function of gate resistor

$$E_{rec} = f(R_g)$$

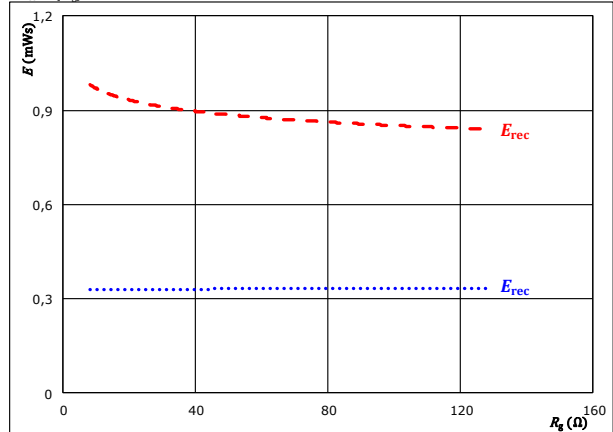

With an inductive load at

$V_{CE} = 600$ V
 $V_{GE} = \pm 15$ V
 $I_c = 15$ A

T_j :

25 °C (dotted blue)
150 °C (dashed red)



Inverter Switching Characteristics

figure 5. IGBT

Typical switching times as a function of collector current

$$t = f(I_C)$$

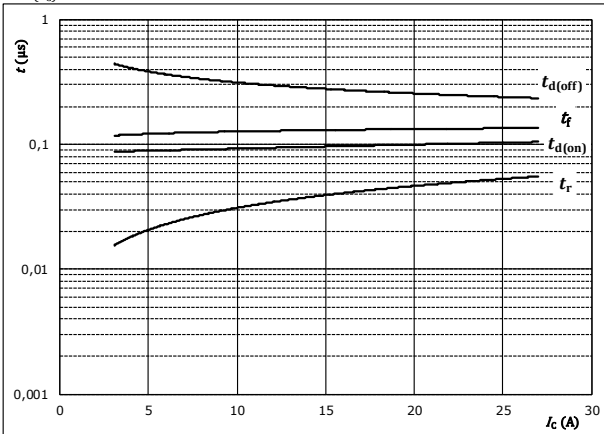

With an inductive load at

$T_j = 150$ °C
 $V_{CE} = 600$ V
 $V_{GE} = \pm 15$ V
 $R_{gon} = 32$ Ω
 $R_{goff} = 32$ Ω

figure 6. IGBT

Typical switching times as a function of gate resistor

$$t = f(R_g)$$

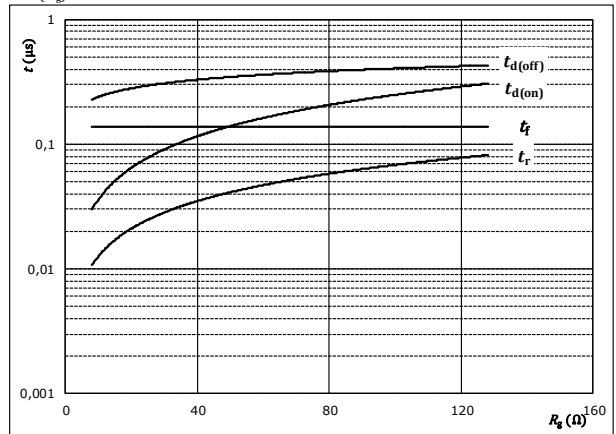

With an inductive load at

$T_j = 150$ °C
 $V_{CE} = 600$ V
 $V_{GE} = \pm 15$ V
 $I_C = 15$ A

figure 7. FWD

Typical reverse recovery time as a function of collector current

$$t_{rr} = f(I_C)$$

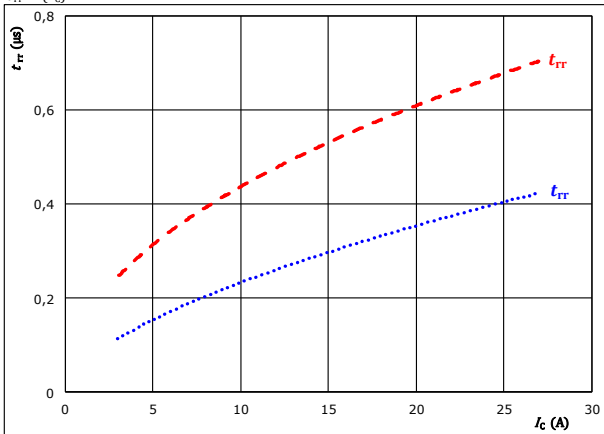

With an inductive load at

$V_{CE} = 600$ V
 $V_{GE} = \pm 15$ V
 $R_{gon} = 32$ Ω

T_j : 25 °C (dotted line)
 150 °C (dashed line)

figure 8. FWD

Typical reverse recovery time as a function of IGBT turn on gate resistor

$$t_{rr} = f(R_{gon})$$

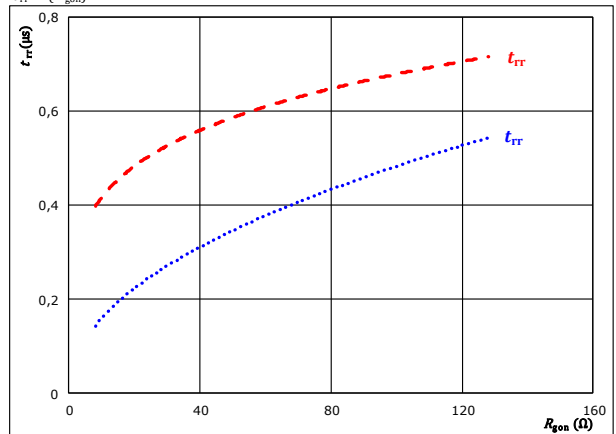

With an inductive load at

$V_{CE} = 600$ V
 $V_{GE} = \pm 15$ V
 $I_C = 15$ A

T_j : 25 °C (dotted line)
 150 °C (dashed line)



Inverter Switching Characteristics

figure 9. FWD

Typical recovered charge as a function of collector current

$$Q_r = f(I_c)$$

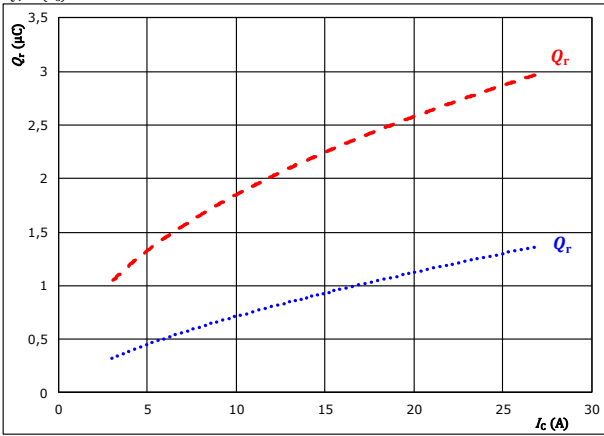

With an inductive load at
 $V_{CE} = 600$ V
 $V_{GE} = \pm 15$ V
 $R_{gon} = 32$ Ω
 T_j : 25 °C (blue dotted line)
 150 °C (red dashed line)

figure 10. FWD

Typical recovered charge as a function of IGBT turn on gate resistor

$$Q_r = f(R_{gon})$$

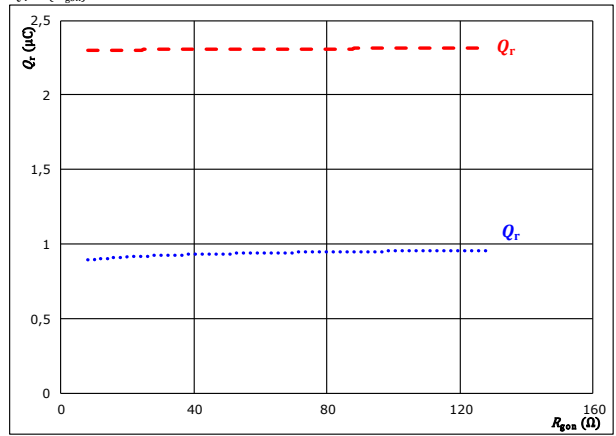

With an inductive load at
 $V_{CE} = 600$ V
 $V_{GE} = \pm 15$ V
 $I_c = 15$ A
 T_j : 25 °C (blue dotted line)
 150 °C (red dashed line)

figure 11. FWD

Typical peak reverse recovery current as a function of collector current

$$I_{RM} = f(I_c)$$

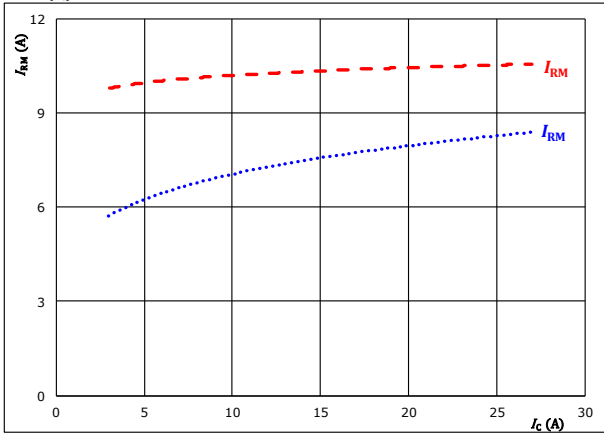

With an inductive load at
 $V_{CE} = 600$ V
 $V_{GE} = \pm 15$ V
 $R_{gon} = 32$ Ω
 T_j : 25 °C (blue dotted line)
 150 °C (red dashed line)

figure 12. FWD

Typical peak reverse recovery current as a function of IGBT turn on gate resistor

$$I_{RM} = f(R_{gon})$$

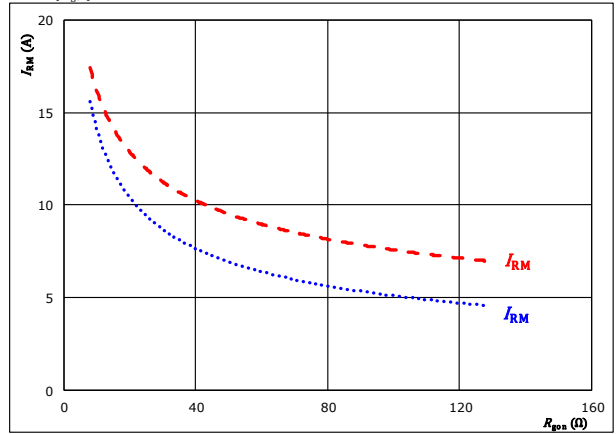

With an inductive load at
 $V_{CE} = 600$ V
 $V_{GE} = \pm 15$ V
 $I_c = 15$ A
 T_j : 25 °C (blue dotted line)
 150 °C (red dashed line)



Inverter Switching Characteristics

figure 13. FWD

Typical rate of fall of forward and reverse recovery current as a function of collector current
 $di_f/dt, di_{rr}/dt = f(I_C)$

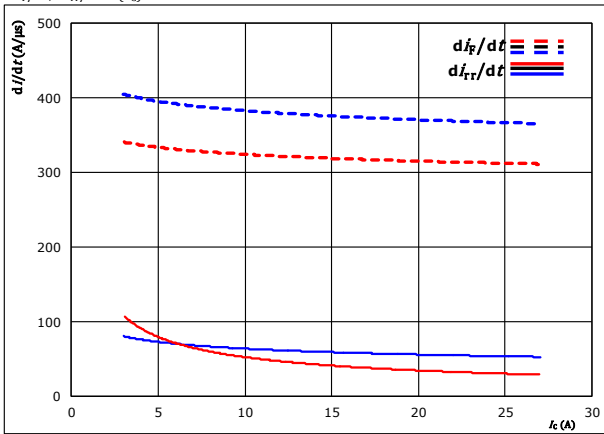

With an inductive load at
 $V_{CE} = 600$ V
 $V_{GE} = \pm 15$ V
 $R_{g\text{on}} = 32$ Ω
 $T_j: 25$ °C
 150 °C

figure 14. FWD

Typical rate of fall of forward and reverse recovery current as a function of IGBT turn on gate resistor
 $di_f/dt, di_{rr}/dt = f(R_{g\text{on}})$

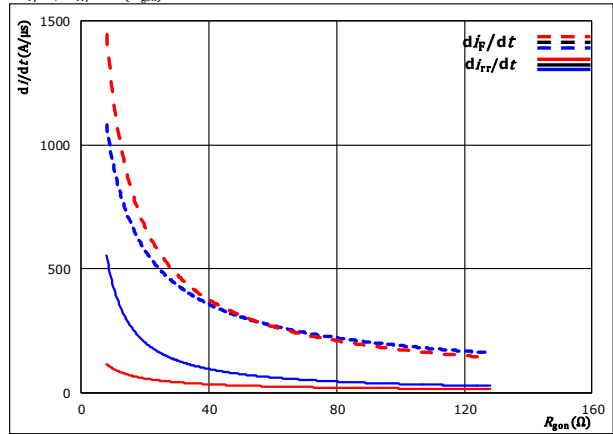

With an inductive load at
 $V_{CE} = 600$ V
 $V_{GE} = \pm 15$ V
 $I_C = 15$ A
 $T_j: 25$ °C
 150 °C

figure 15. IGBT

Reverse bias safe operating area
 $I_C = f(V_{CE})$

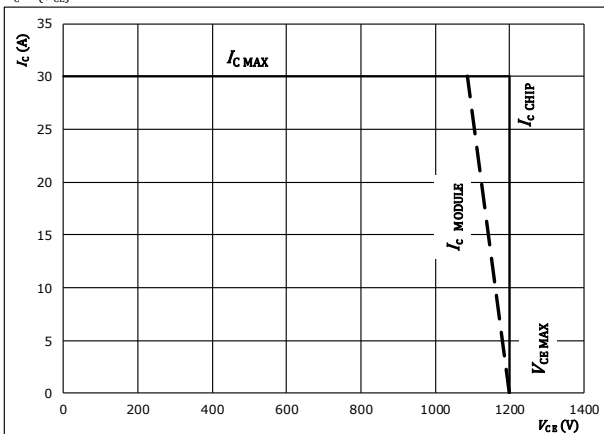

At
 $T_j = 150$ °C
 $R_{g\text{on}} = 32$ Ω
 $R_{g\text{off}} = 32$ Ω



Inverter Switching Definitions

General conditions		
T_j	=	125 °C
R_{gon}	=	32 Ω
R_{goff}	=	32 Ω

figure 1. IGBT

Turn-off Switching Waveforms & definition of t_{doff} , t_{Eoff} (t_{Eoff} = integrating time for E_{off})

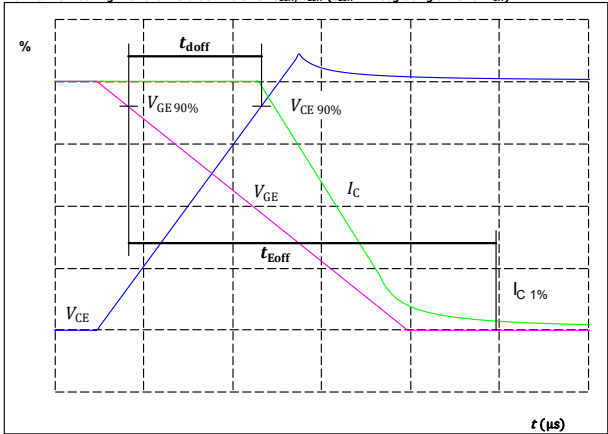

$V_{CE}(0\%) =$	-15	V
$V_{GE}(100\%) =$	15	V
$V_C(100\%) =$	600	V
$I_C(100\%) =$	15	A
$t_{doff} =$	288	ns

figure 2. IGBT

Turn-on Switching Waveforms & definition of t_{don} , t_{Eon} (t_{Eon} = integrating time for E_{on})

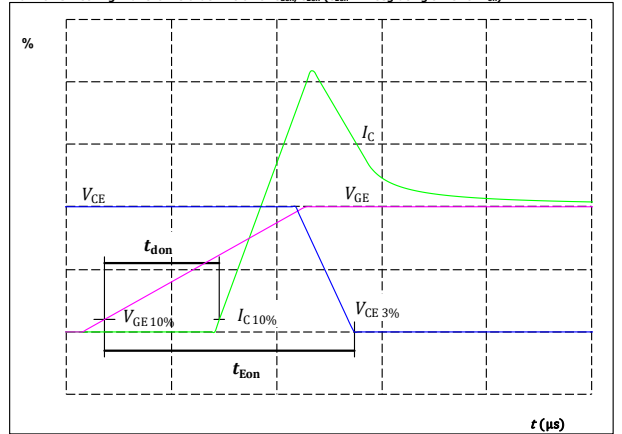

$V_{CE}(0\%) =$	-15	V
$V_{GE}(100\%) =$	15	V
$V_C(100\%) =$	600	V
$I_C(100\%) =$	15	A
$t_{don} =$	98	ns

figure 3. IGBT

Turn-off Switching Waveforms & definition of t_f

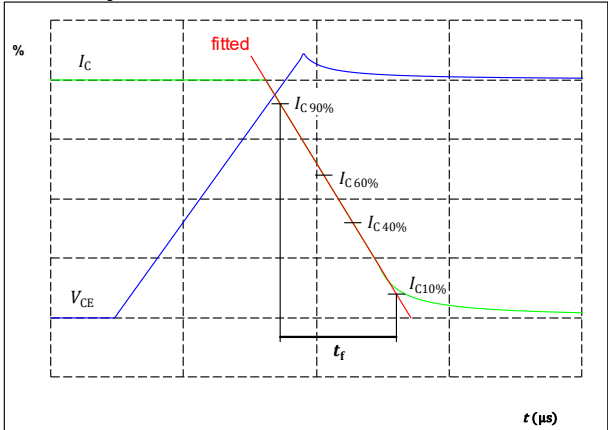

$V_C(100\%) =$	600	V
$I_C(100\%) =$	15	A
$t_f =$	134	ns

figure 4. IGBT

Turn-on Switching Waveforms & definition of t_r

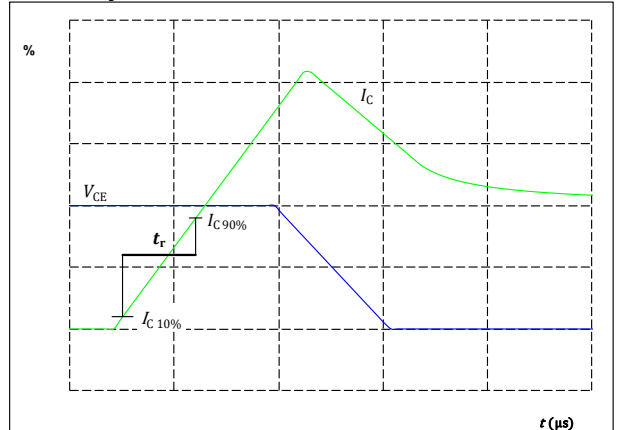

$V_C(100\%) =$	600	V
$I_C(100\%) =$	15	A
$t_r =$	35	ns



Inverter Switching Characteristics

figure 5. FWD

Turn-off Switching Waveforms & definition of t_{rr}

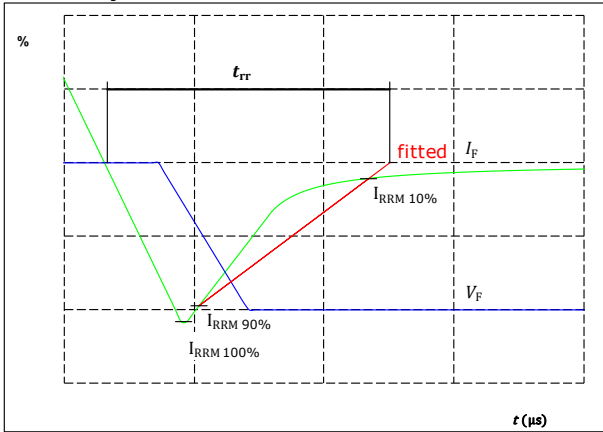

$V_F(100\%) =$	600	V
$I_F(100\%) =$	15	A
$I_{RRM}(100\%) =$	11	A
$t_{rr} =$	536	ns

figure 6. FWD

Turn-on Switching Waveforms & definition of t_{Qr} ($t_{Qr} =$ integrating time for Q_r)

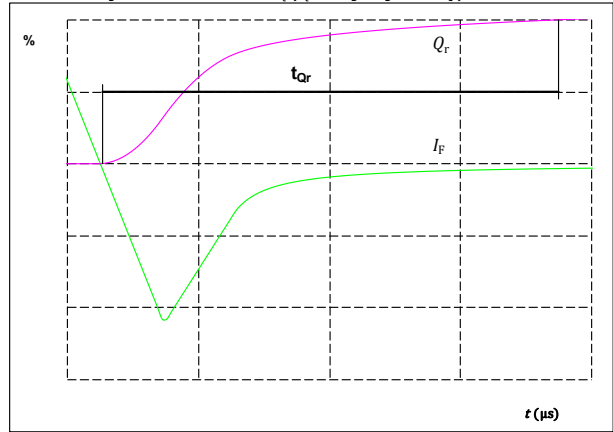

$I_F(100\%) =$	15	A
$Q_r(100\%) =$	2,38	μC



Vincotech

Ordering Code & Marking									
Version				Ordering Code					
With std lid (6.5mm height) + no thermal grease				V23990-K219-F40-/0A/-PM					
With thin lid (2.8mm height) + no thermal grease				V23990-K219-F40-/0B/-PM					
With std lid (6.5mm height) + thermal grease (0,8 W/mK, P12, silicone-based)				V23990-K219-F40-/1A/-PM					
With thin lid (2.8mm height) + thermal grease (0,8 W/mK, P12, silicone-based)				V23990-K219-F40-/1B/-PM					
With std lid (6.5mm height) + thermal grease (2,5 W/mK, TG20032, silicone-free)				V23990-K219-F40-/4A/-PM					
With thin lid (2.8mm height) + thermal grease (2,5 W/mK, TG20032, silicone-free)				V23990-K219-F40-/4B/-PM					
With std lid (6.5mm height) + thermal grease (2,5 W/mK, HPTP, silicone-based)				V23990-K219-F40-/5A/-PM					
With thin lid (2.8mm height) + thermal grease (2,5 W/mK, HPTP, silicone-based)				V23990-K219-F40-/5B/-PM					
VIN WWYY NNNNNNVV LLLL SSSS			Text	VIN	Date code	Name&Ver	UL	Lot	Serial
				VIN	WWYY	NNNNNNVV	UL	LLLLL	SSSS
			Datamatrix	Type&Ver	Lot number	Serial	Date code		
				NNNNNNVV	LLLLL	SSSS	WWYY		

PCB pad table			
Pin	X	Y	Function
1	15,93	-14,6	G5
2	15,93	-9,8	W
3	15,93	-5	W
4	Not assembled		
5	15,93	7,62	G6
6	15,93	12,62	+T
7	15,93	15,8	-T
8	Not assembled		
9	8,23	12,62	-DC/W
10	8,23	15,8	-DC/W
11	7,73	-14,6	G3
12	Not assembled		
13	Not assembled		
14	0,53	9,45	G4
15	0,53	12,62	-DC/V
16	0,53	15,8	-DC/V
17	-0,47	-14,6	V
18	-0,47	-9,8	V
19	Not assembled		
20	Not assembled		
21	-7,17	12,62	-DC/U
22	-7,17	15,8	-DC/U
23	-8,07	-14,6	+DC
24	-8,07	-9,8	+DC
25	-15,02	-15,8	G1
26	-15,02	-9,8	U
27	-15,02	0	U
28	Not assembled		
29	-15,02	15,8	G2

Pad positions refers to center point. For more informations on pad design please see package data



Vincotech

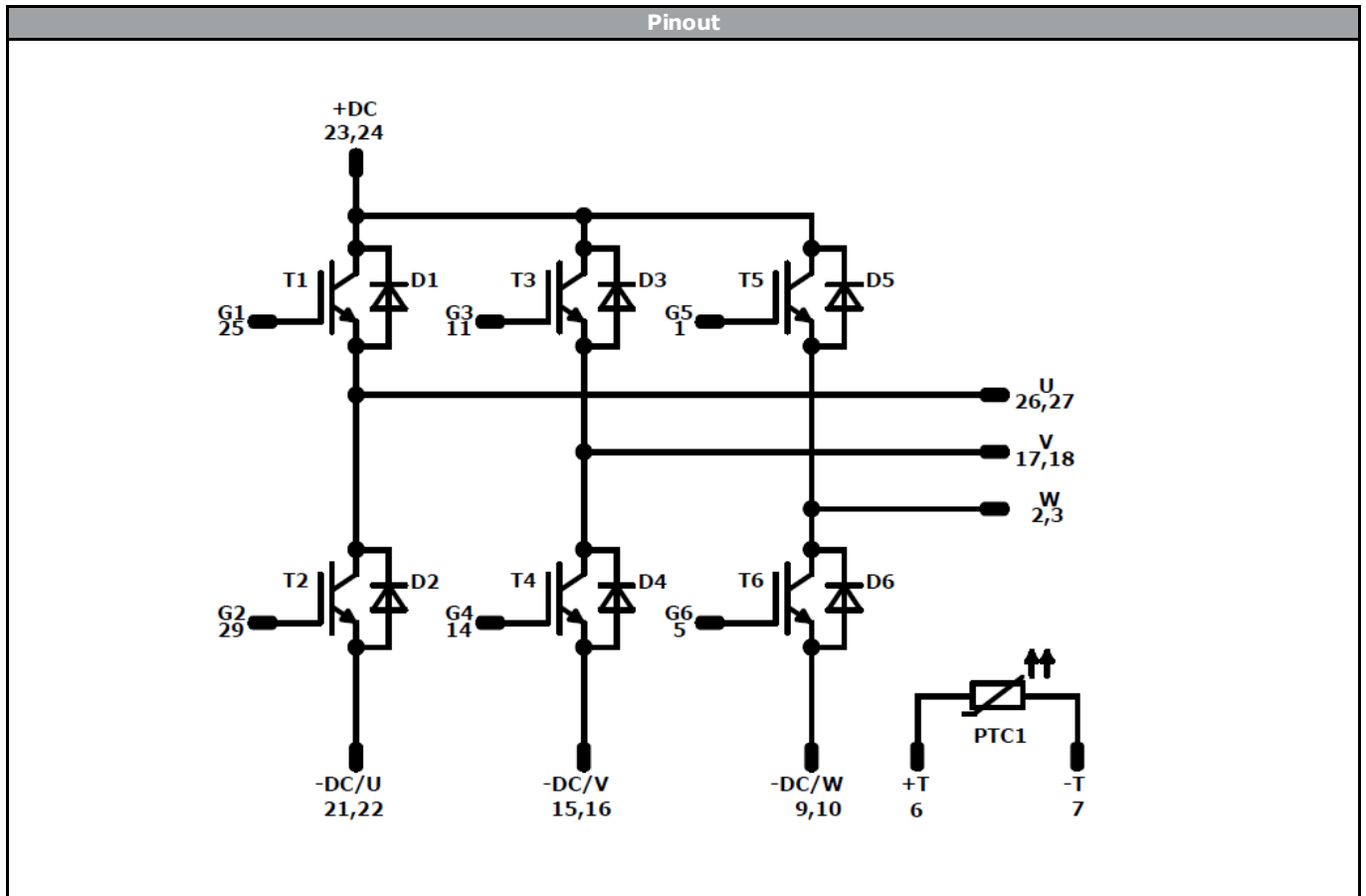

Identification					
ID	Component	Voltage	Current	Function	Comment
T2, T1, T4, T3, T6, T5	IGBT	1200 V	20 A	Inverter Switch	
D1, D2, D3, D4, D5, D6	FWD	1200 V	15 A	Inverter Diode	
PTC1	PTC			Thermistor	



Vincotech

Packaging instruction			
Standard packaging quantity (SPQ) 120	>SPQ	Standard	<SPQ Sample

Handling instruction
Handling instructions for MiniSkiiP® 1 packages see vincotech.com website.

Package data
Package data for MiniSkiiP® 1 packages see vincotech.com website.

UL recognition and file number
This device is certified according to UL 1557 standard, UL file number E192116. For more information see vincotech.com website. 

Document No.:	Date:	Modification:	Pages
V23990-K219-F40-D3-14	13 Sep. 2018	HPTP introduced	all

DISCLAIMER

The information, specifications, procedures, methods and recommendations herein (together "information") are presented by Vincotech to reader in good faith, are believed to be accurate and reliable, but may well be incomplete and/or not applicable to all conditions or situations that may exist or occur. Vincotech reserves the right to make any changes without further notice to any products to improve reliability, function or design. No representation, guarantee or warranty is made to reader as to the accuracy, reliability or completeness of said information or that the application or use of any of the same will avoid hazards, accidents, losses, damages or injury of any kind to persons or property or that the same will not infringe third parties rights or give desired results. It is reader's sole responsibility to test and determine the suitability of the information and the product for reader's intended use.

LIFE SUPPORT POLICY

Vincotech products are not authorised for use as critical components in life support devices or systems without the express written approval of Vincotech.

As used herein:

1. Life support devices or systems are devices or systems which, (a) are intended for surgical implant into the body, or (b) support or sustain life, or (c) whose failure to perform when properly used in accordance with instructions for use provided in labelling can be reasonably expected to result in significant injury to the user.
2. A critical component is any component of a life support device or system whose failure to perform can be reasonably expected to cause the failure of the life support device or system, or to affect its safety or effectiveness.