

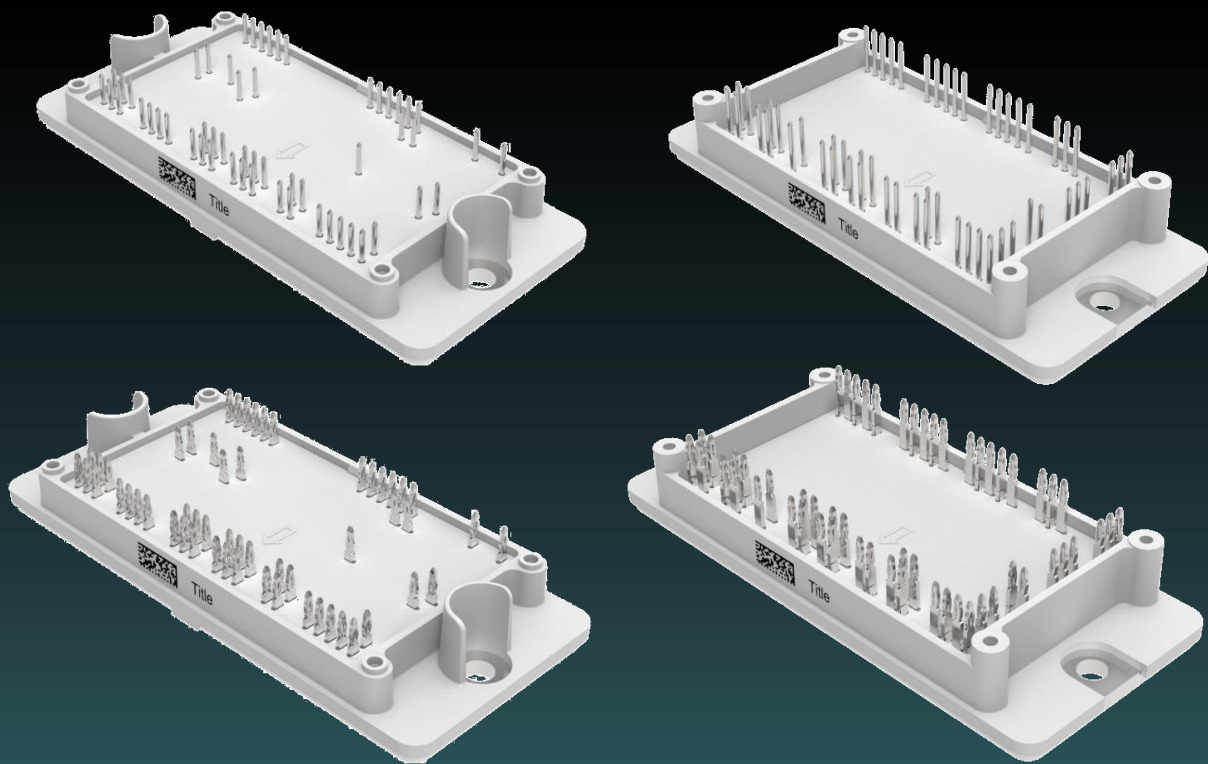

Vincotech

Handling Instructions

for *flow 2* packages



***This document is valid for all type of flow 2 modules:
12/13 mm & 17 mm housing, with solder & Press-fit pins***

Date: 13.04.2018

Revision:

Created by: M. Buza

Rev. 05

Proprietary data, company confidential. All rights reserved.



Table of Contents

1	General instructions	6
2	Specification for PCBs.....	7
2.1	Specifications for modules with Press-fit pins	7
2.2	Specification for modules with solder pins.....	8
2.3	Specification for modules with Press-fit pins that are soldered to the PCB	8
2.4	Required PCB cutouts for insulating ribs, screwing holes.....	9
2.4.1	For 12/13 mm type module (Press-fit and solder pins)	9
2.4.1.1	OPTION 1: Mounted on module with distance of 12 mm	9
2.4.1.2	OPTION 2: Mounted on module with distance of 13 mm	9
2.4.2	For 17 mm type module (Press-fit and solder pins)	10
2.5	Recommended PCB-thicknesses and mounting heights for module types	11
2.5.1	For 12/13 mm type module	11
2.5.1.1	Mounting with distance of 12 mm.....	11
2.5.1.2	Mounting with distance of 13 mm.....	12
2.5.2	For 17 mm type module	12
2.5.2.1	OPTION 1: Without spacers	12
2.5.2.2	OPTION 2: With spacers.....	13
3	Specification for baseplate	13
4	Specification for heat sinks	15
5	Specification for thermal interface materials.....	15
5.1	OPTION 1: Thermal paste	15
5.2	OPTION 2: Pre-applied thermal interface material.....	15
6	Specification for fastening screws to the heat sink	15
6.1	Screw with pre-assembled washers.....	16
6.2	Mounting with automatic screwdriver	16
7	Press in process of modules with Press-fit pins	17
7.1	Press-in construction.....	17
7.1.1	Press-in tool.....	19
7.1.1.1	Module without thermal interface material	19
7.1.1.2	Modules with thermal interface material	21
7.1.2	Supporting tool	22
7.2	Press-in process parameters	22
7.2.1	The basic requirement for the press in process	23
7.3	Process control parameters	23
8	Press-out process for modules with Press-fit pins.....	25
8.1	Press-out tool.....	26



Table of Contents

8.2	Press-out process characteristics	28
8.2.1	Press-out process parameters	28
8.3	Disassembling by hand.....	28
9	Mounting of modules with solder pins.....	29
9.1	Modules with 4 towers.....	29
9.1.1	Using screws to fix the module to the PCB	29
9.1.2	Using soldering jig (without using screws)	29
10	Recommendation for soldering	30
10.1	Wave soldering of modules with solder pins	30
10.2	Hand soldering parameters	30
11	ESD protection	31
12	Environmental conditions.....	31
12.1	Parameters of environment classes	31
12.1.1	Climatic conditions.....	31
12.1.2	Biological conditions.....	32
12.1.3	Chemically active substances	32
12.1.4	Mechanically active substances.....	33
12.1.5	Mechanical Conditions	33
13	Handling of trays	35
14	Disclaimer	36



Table of Figures

Figure 1: Module with PCB and heat sink	6
Figure 2: Chemical tin plating (for illustration only, no real proportions)	7
Figure 3: HAL tin plating (for illustration only, no real proportions)	7
Figure 4: Solder pin diameter.....	8
Figure 5: PCB's cutout for 12/13 mm type module when the PCB distance is 12 mm.....	9
Figure 6: PCB's cutout for 12/13 mm type module when the PCB distance is 13 mm.....	10
Figure 7: PCB's cutout for 17 mm type modules	10
Figure 8: Scratch dimensions	13
Figure 9: Polished baseplate	14
Figure 10: Discoloration of baseplate	14
Figure 11: Fingerprint on the baseplate.....	14
Figure 12: Recommended torque and speed curve.....	17
Figure 13: Recommended construction for the press in process.....	18
Figure 14: Press-in tools closed, module is pressed in	19
Figure 15: Recommended press-in tool for modules without thermal interface materials	20
Figure 16: Recommended press-in tool for modules with thermal interface material	21
Figure 17: The recommended hole and cutout dimensions for supporting tool	22
Figure 18: Press-in depth in PCB	23
Figure 19: Typical press-in diagram of a 20 pin module.....	24
Figure 20: Exploded view of the press-out tool.....	25
Figure 21: Working position of the press-out tool	25
Figure 22: Recommended dimensions of the upper tool.....	26
Figure 23: Recommended dimensions of the lower tool	27
Figure 24: Force-path diagram of the press-out process	28
Figure 25: Cutting edge	28
Figure 26: Assembly illustration	29
Figure 27: Plated through hole, good soldering	30
Figure 28: Typical profile for wave soldering	30
Figure 29: Layer of trays	35



Revision History

Date	Revision Level	Description	Page Number(s)
13.04.2018	05	Correction/change/extend at sections: 1; 6;6.2;7.1;9;10;12.1;12.2	6,15,16,18,28,29,33,34
25.07.2017	04	Correction/change/extend Sections: cover, 2.1, 2.3, 6, 7.1.1.2, 7.1.2, 7.2, 7.3, 12.1.5	7, 8, 9, 16, 20, 21, 32, 33
23.06.2015	03	New template; Change/extend Sections: 1, 2.1, 2.5.1.1, 6, 9, 12	all; 6, 7, 11, 16, 28, 30
17.02.2014	02	Soldering option for Press-fit pin	
29.10.2013	01	New document	



1 General instructions

The *flow 2* type modules have to be mounted to a PCB. The electrical connections between module and PCB can be made by soldering or by Press-fit technology. In applications where the module is attached to a heat sink, the PCB must also be attached to this heat sink. Figure 1 shows how this attachment can be achieved with threaded spacers.

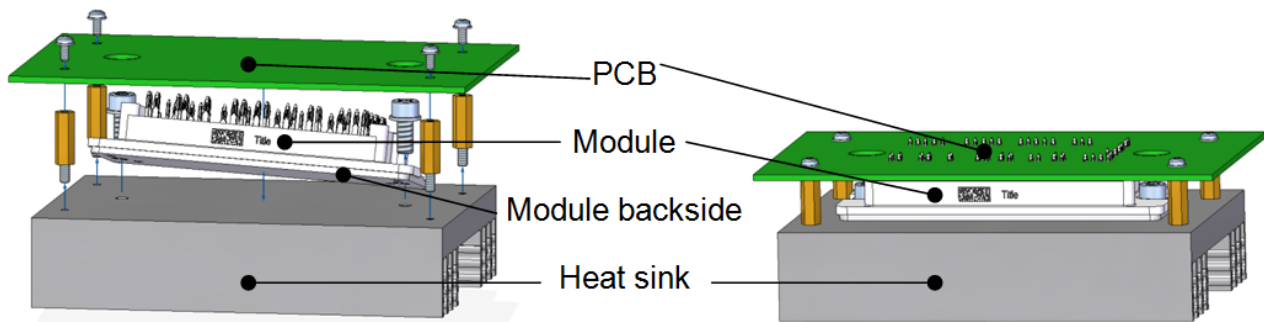

Figure 1: Module with PCB and heat sink

The distance between the top surface of the heat sink and the bottom plane of the PCB is defined by the module type, which can be 12 mm, 13 mm or 17 mm. PCB spacers can be used to obtain the correct spacing. The number and the position of the fixing points depend on the design of the circuit, the location of different masses like capacitors or inductors and the environment of the system. General recommendation cannot be given. The recommended heights of these spacers are can be seen in section 2.5, depending on the module's dimension.

During the assembly process, a single pin is not allowed to be drawn or pushed more than ± 0.2 mm or loaded with a force greater than 35 N (except during pressing-in of Press-fit pins). The special design of the Press-fit pins prevents higher than 0.1 mm deformation of pins during pressing-in process.

The tension of the pin must not exceed ± 5 N at a maximum substrate temperature of 100 C.

2 Specification for PCBs

- Printed board material meets the requirements of IEC 61249-2-7.
- The maximum number of conductive layers is not limited.

2.1 Specifications for modules with Press-fit pins

- Printed board thickness must not be less than 1.6 mm (thinner PCBs require additional testing and will be performed upon request).
- PCB should be covered with solder mask on both sides.
- Plated through-hole specifications for Press-fit pin:
 - Hole diameter before plating: 1.6 mm \pm 0.025 mm
 - Thickness of the PTH wall > 25 μ m Cu
 - Plated hole final dimension: 1.45 mm +0.09 mm / 0.06 mm
 - Minimum Cu width of the annular ring > 0.1 mm
 - Through hole position accuracy \pm 0.04 mm
- Plating material:
 - for chemical tin plating (Sn): 0.5 μ m to 10 μ m

The PCB can be disassembled and reused 2 more times.

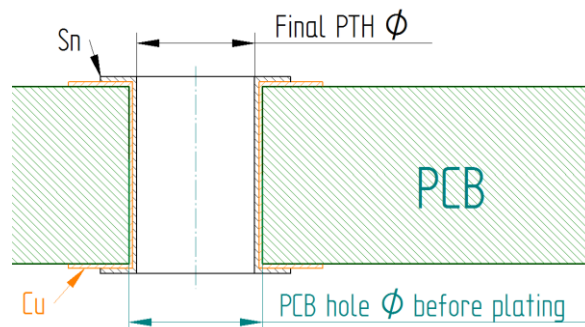

Figure 2: Chemical tin plating (for illustration only, no real proportions)

- for HAL tin plating (Sn): 0.5 μ m to 50 μ m

The PCB can be disassembled and reused 2 more times.

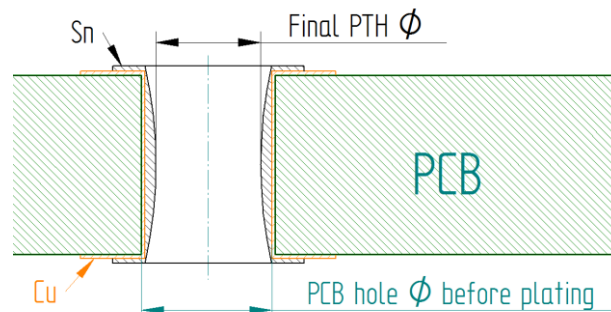

Figure 3: HAL tin plating (for illustration only, no real proportions)

- Au: not generally released; individual release of PCB system required
- Minimum distance between the edge of the PCB and the centre of the pin hole: 4 mm
- Minimum distance between the centre of the pin hole and the component on the PCB: 4 mm
- For any other requirements IEC 60352-5 2008 standard should be considered



2.2 Specification for modules with solder pins

- After screwing the module, all pins must be soldered into the PCB. The hole diameters on the PCB has to be designed according to the soldering pin diameter which is $\varnothing 1 \text{ mm} \pm 0.05 \text{ mm}$.
- For further dimensions or a 3D model please contact your local sales manager.

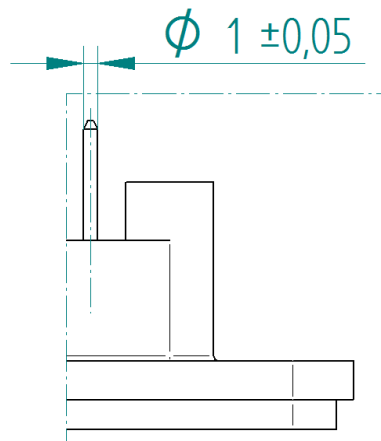

Figure 4: Solder pin diameter

2.3 Specification for modules with Press-fit pins that are soldered to the PCB

In cases where the Press-fit pins are soldered instead of pressed into the PCB the recommended PCB hole diameter is $1.85 \text{ mm} \pm 0.1 \text{ mm}$. In these cases, the annular ring must be designed according to the standards for through hole components to ensure proper soldering of the Press-fit pins.

Please also read section 3010 Recommendation for soldering.



2.4 Required PCB cutouts for insulating ribs, screwing holes

2.4.1 For 12/13 mm type module (Press-fit and solder pins)

2.4.1.1 OPTION 1: Mounted on module with distance of 12 mm

- washer DIN125A M2.5 should be used together with screw BN82428 (solder pin modules only)

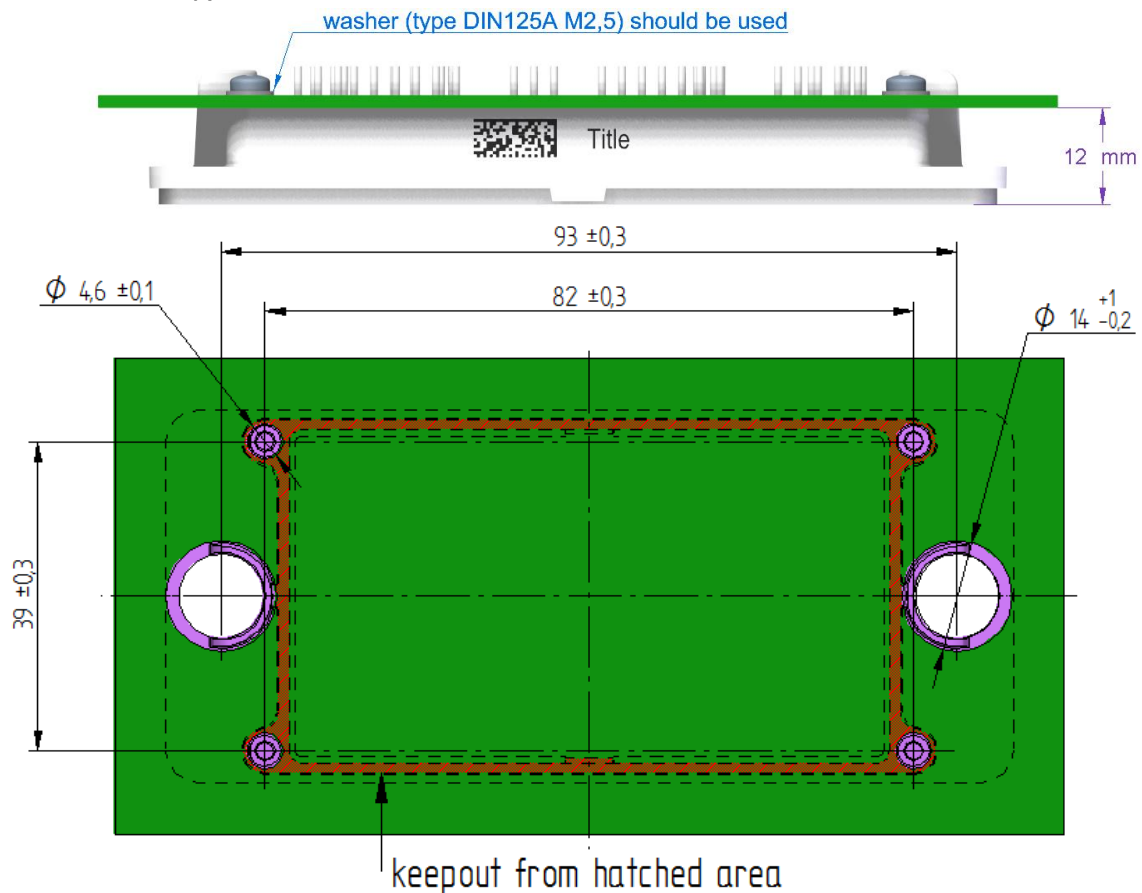

Figure 5: PCB's cutout for 12/13 mm type module when the PCB distance is 12 mm

2.4.1.2 OPTION 2: Mounted on module with distance of 13 mm



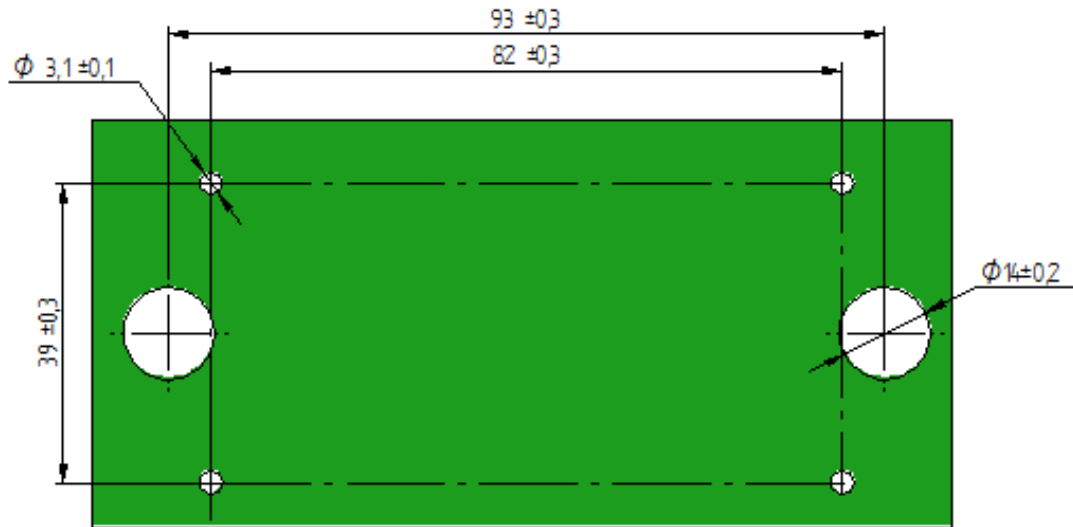

Figure 6: PCB's cutout for 12/13 mm type module when the PCB distance is 13 mm

2.4.2 For 17 mm type module (Press-fit and solder pins)

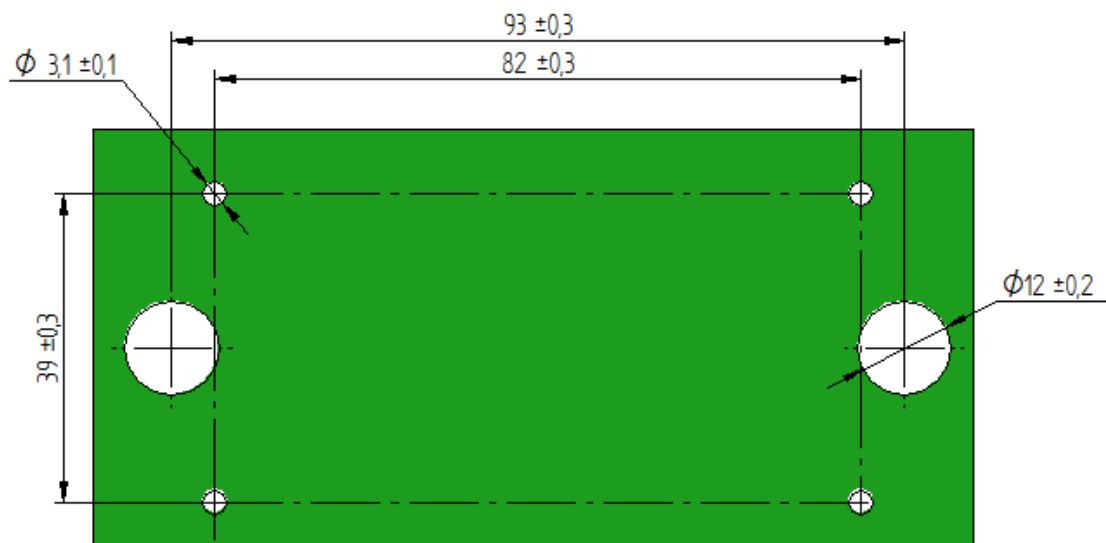
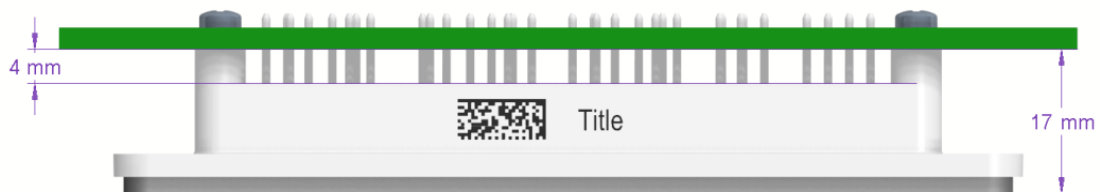

Figure 7: PCB's cutout for 17 mm type modules



2.5 Recommended PCB-thicknesses and mounting heights for module types

The distance between the top surface of the heat sink and the bottom plane of the PCB is defined by the module size: 17 mm or 12/13 mm. For fixing the PCB spacers can be used (press-fit pin modules only). The number and the position of the fixing points depend on the design of the circuit, location of different masses like capacitors or inductors and the environment of the system. General recommendation cannot be given. The recommended heights of these spacers are given on the following sections.

2.5.1 For 12/13 mm type module

2.5.1.1 Mounting with distance of 12 mm

2.5.1.1.1 OPTION 1: Without spacers

- for solder pin modules only

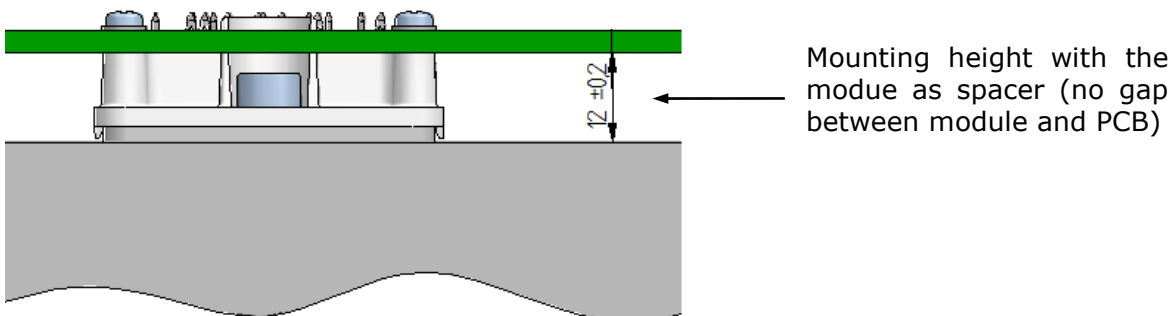

2.5.1.1.2 OPTION 2: With spacers

- for Press-fit pin modules only

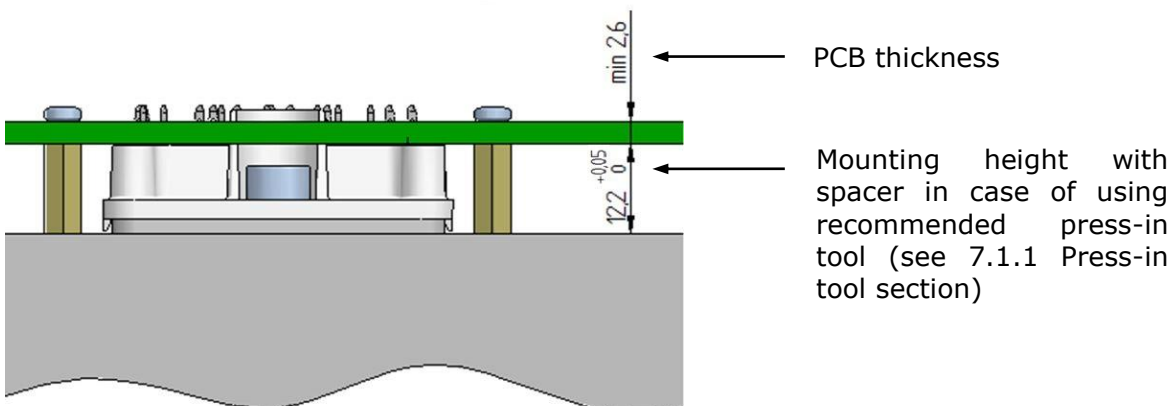



2.5.1.2 Mounting with distance of 13 mm

2.5.1.2.1 OPTION 1: Without spacers

- for solder pin modules only

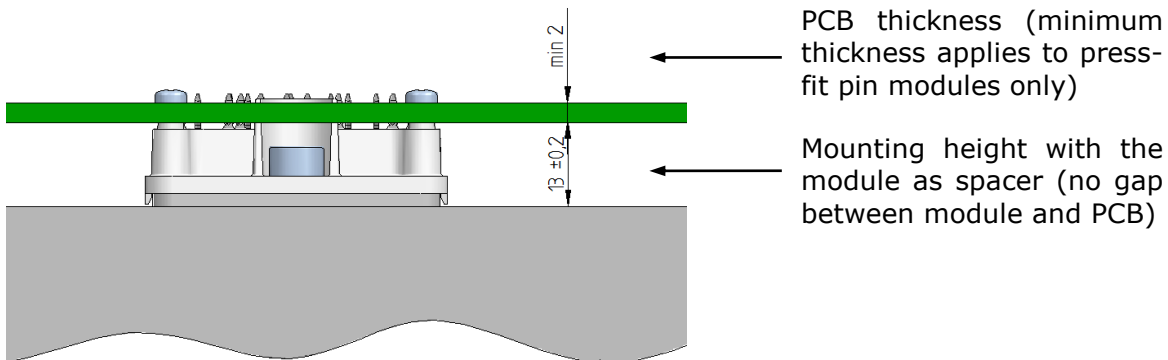

2.5.1.2.2 OPTION 2: With spacers

- for Press-fit pin modules only

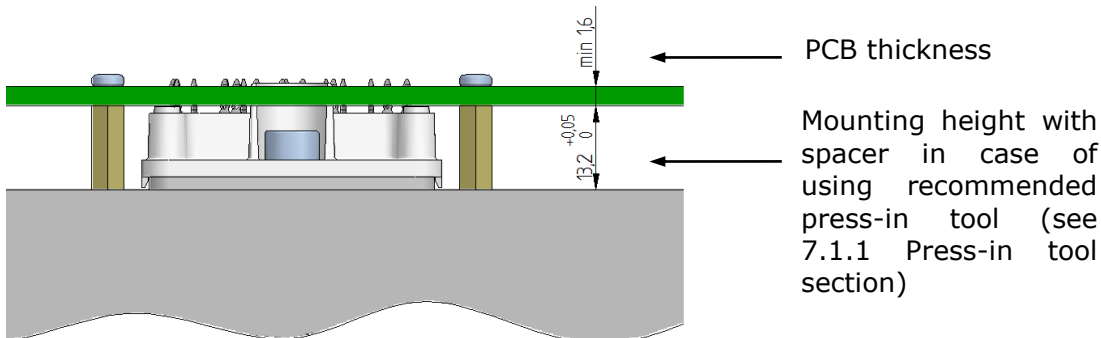

2.5.2 For 17 mm type module

2.5.2.1 OPTION 1: Without spacers

- for solder pin modules only

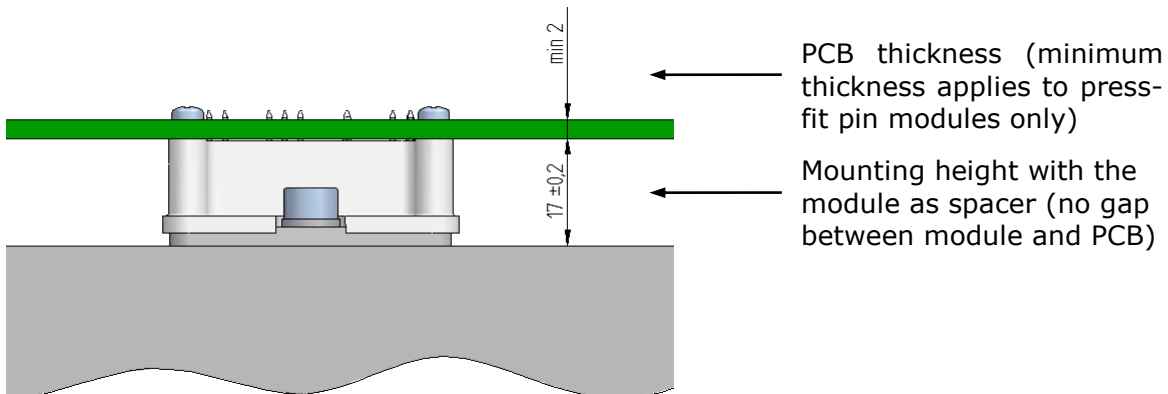



2.5.2.2 OPTION 2: With spacers

- for Press-fit modules only

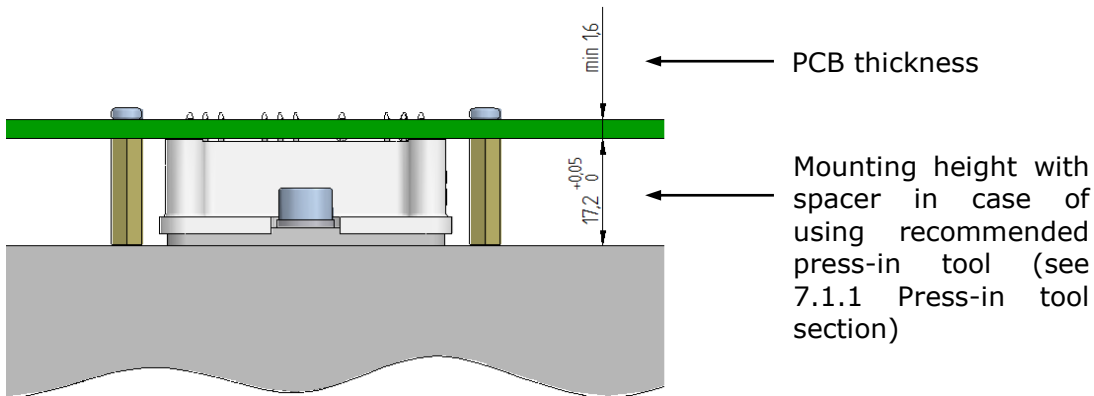

3 Specification for baseplate

The thermal properties are not affected if the dimensions of the surface imperfections are within the following values.

- Polishing is allowed on the whole nickel plated surface if copper doesn't become visible.
- If copper becomes visible, the unit is scratched and following acceptance criteria should be used. The depth and width of the scratch can't exceed 200 μm and 800 μm , respectively. The length of the scratch does not matter but the total area of scratches must not exceed 5 % of the total substrate surface.

Discolorations and fingerprints are only surface imperfections and do not affect the module's functionality.

Substrate surface imperfections can be seen on the figures below.

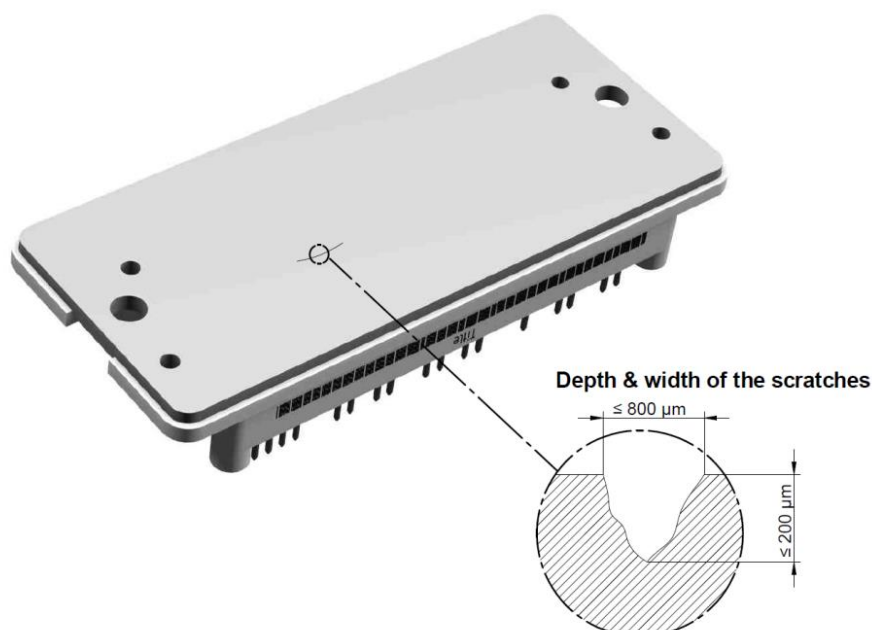

Figure 8: Scratch dimensions



Figure 9: Polished baseplate

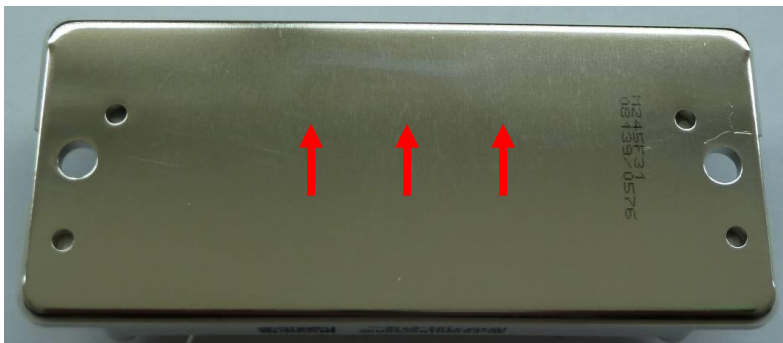

Figure 10: Discoloration of baseplate



Figure 11: Fingerprint on the baseplate



4 Specification for heat sinks

The whole heat sink surface under the module must be plane, clean and free of particles.

- The flatness tolerance should be: $< 25 \mu\text{m}$ in general.
- In case the thermal paste is thicker than $50 \mu\text{m}$ the flatness tolerance can be $< 50 \mu\text{m}$.
(A flatness tolerance specifies a tolerance zone defined by two parallel planes within which the surface must lie.)
- The surface roughness should be less than: $R_z < 10 \mu\text{m}$.
- Heat sink surface imperfections should be within the values described for the module baseplate surface (please refer to section 3 Specification for baseplate).

5 Specification for thermal interface materials

5.1 OPTION 1: Thermal paste

- A. Apply a homogeneous layer of thermal conductive paste over the whole backside of the module, with a roller or spatula.
- B. Apply thermal paste in a honeycomb pattern. The preferred technology for paste application is screen printing. For a drawing of the pattern please contact your local sales representative.

The recommended thermal paste thickness is $80 \mu\text{m} \pm 20 \mu\text{m}$ in both cases.

Thermal paste thicker than recommended will increase thermal resistance (R_{th}).

5.2 OPTION 2: Pre-applied thermal interface material

- The modules may have already been pre-printed with thermal interface material.
 - For modules with Press-fit pins a unique press-in tool (see section 7.1.1 Press-in tool) has to be used or the module has to be mounted first to the heat sink and then pressed into the PCB.

6 Specification for fastening screws to the heat sink

A torque wrench shall be used to tighten the mounting screws at the specified torque as excessive torque may result in damage or degradation of the device. The inaccuracy of torque wrench tightening method can range up to $\pm 12\%$. This has to be taken into account to prevent over-tightening the fastener.

- Screw size M5, recommended screw type DIN 7984 (ISO14580)
- The recommended material strength class for the screw is 8.8 (ISO-898-1)-any deviation from the recommended material can be used but should be tested
- Flat washer $D = \text{max. } 10 \text{ mm}$ DIN 433 (ISO 7092)
- Spring washer $D = \text{max. } 10 \text{ mm}$ DIN127 or DIN 128
- Mounting torque: $3 \text{ Nm} < M_a < 6 \text{ Nm}$

Due to excessive temperature fluctuations washers should be used to prevent the loosening of the screws. After accurate tightening of the screws the spring washer exerts a constant force on the joint. The flat washer distributes this force on the plastic surface.



6.1 Screw with pre-assembled washers

Screws with pre-assembled washers (SEMS or kombi screws) combine the screw and the washers into a single component. These screws eliminate the need to slip the washers into place by hand, boosting the speed and efficiency of the assembly process. The specifications of these screws are provided below:

- Screw size M5 according to DIN 6900 (ISO 10644; JIS B1188)
- The recommended material strength class for the screw is 8.8 (ISO-898-1)-any deviation from the recommended material can be used but should be tested
- Flat washer according to DIN 6902 Type C (ISO 10673 Type S; JIS B1256)
- Size of outer diameter \varnothing 10 mm can be fitted into the module.
- Split lock spring washer according to DIN 6905 (JIS B1251)
- Mounting torque range: $3 \text{ Nm} < M_s < 6 \text{ Nm}$

The worst case of the above specification is considered at Clearance/Creepage distance calculation.

6.2 Mounting with automatic screwdriver

For a fast, reliable and repeatable screwing process an automatic screwdriver with two stage tightening method is recommended. The screwdriver starts fast in the first stage and slows down after the first target torque is reached to accurately tighten the screw to the final target. For torque and speed recommendations see below the curves (Figure 12: Recommended torque and speed curve) and values:

Torque

- Cycle start: 0.9 Nm
- First target: 1.5 Nm
- Final torque min.: 5.6 Nm
- Final target: 5.8 Nm
- Final torque max.: 6 Nm

Speed

- Soft start speed: 96 rpm
- Step 1 speed: max. 650 rpm
- Step 2 speed: max. 12 rpm

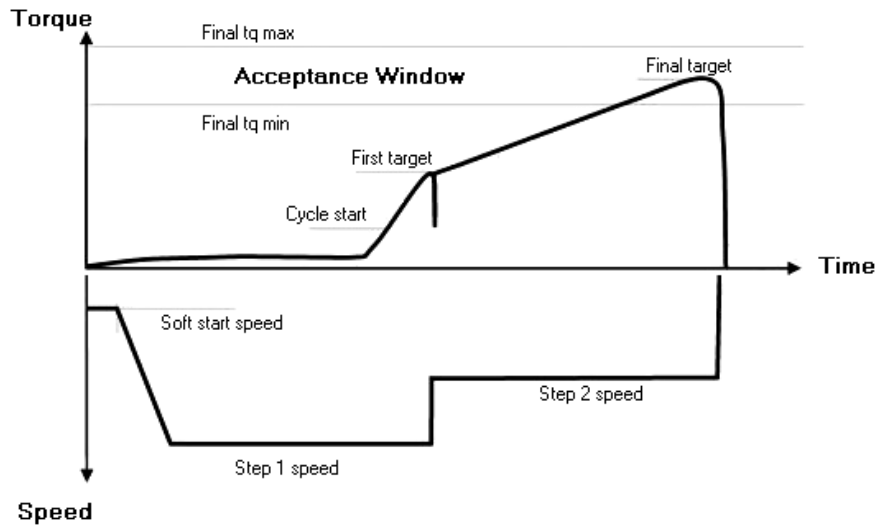

Figure 12: Recommended torque and speed curve

7 Press in process of modules with Press-fit pins

7.1 Press-in construction

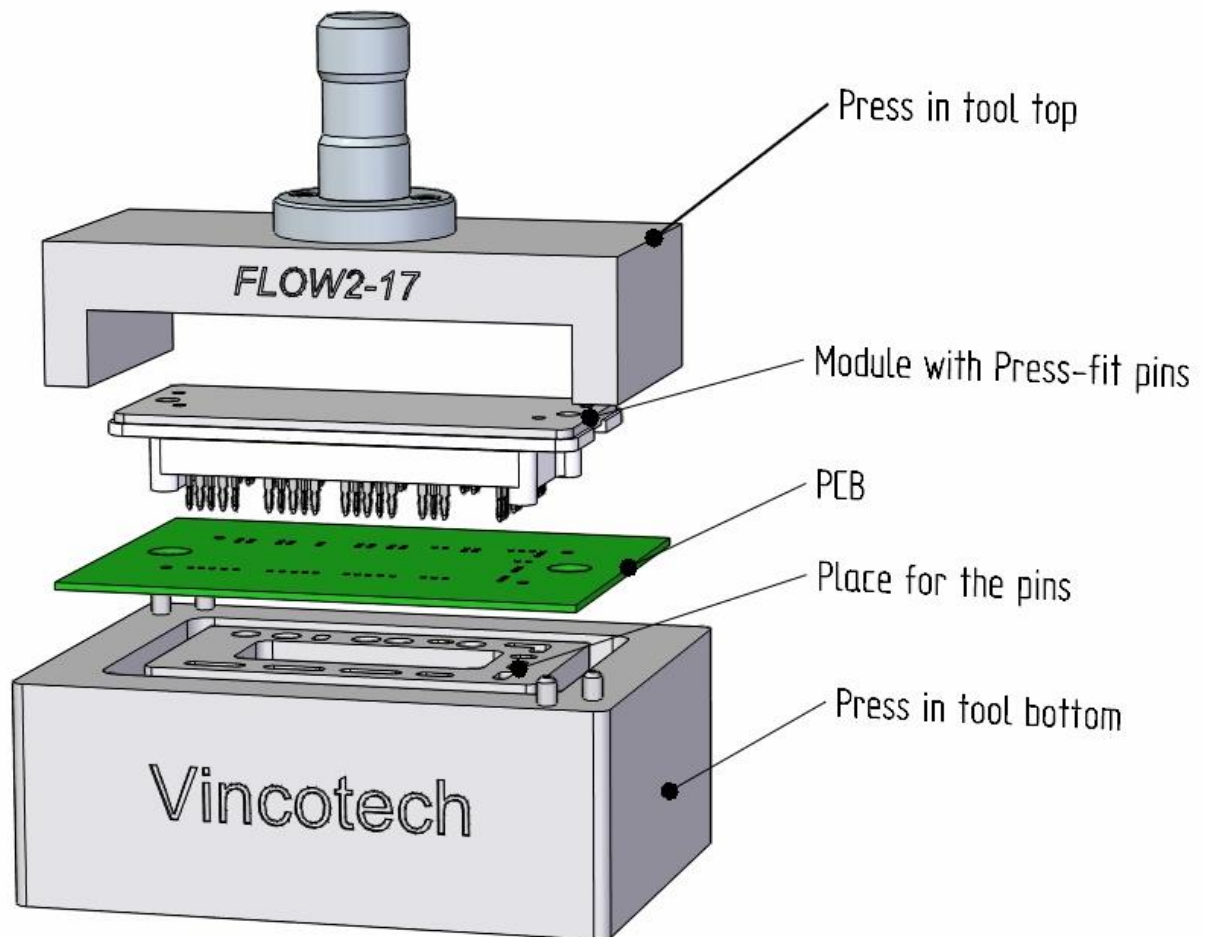

Figure 13: Recommended construction for the press in process

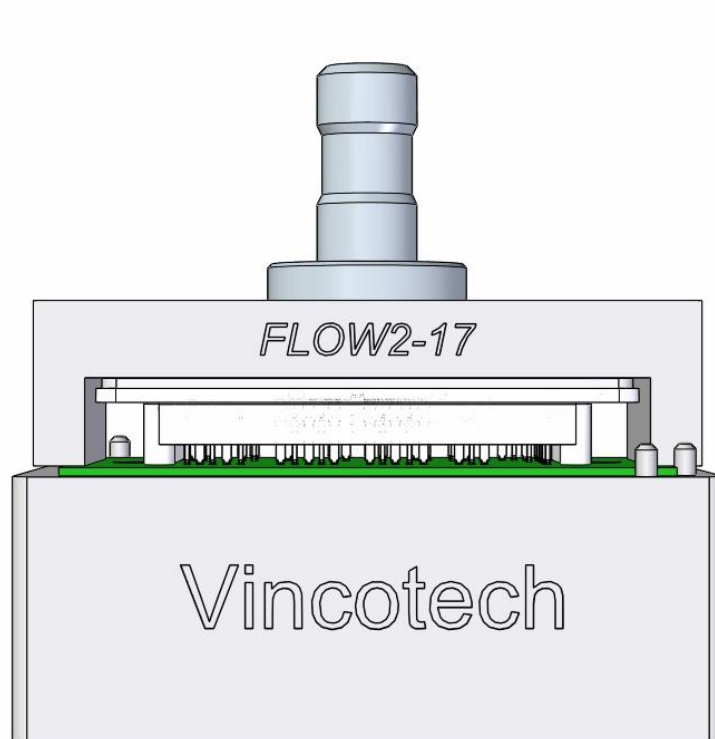

Figure 14: Press-in tools closed, module is pressed in

- The module can be pressed into the PCB from the top (as Figure 13 & Figure 14 shows) or the PCB can be pressed onto the module from the top (the module is below the PCB).
- The preferred method is to press the module into the PCB from the top. This method will be discussed in this document.
- Pressing multiple modules into one PCB can be done one by one (subsequently) or all at once.
- Pressing multiple modules at the same time requires a press-in tool according to the above detailed single tool. The tool has to ensure the correct leveling of the modules and PCB to avoid mechanical stress.
- The "U-shape" tool (14. Figure) is only because to keep the distance between the PCB and the module backside. Depending on the PCB layout the geometry and the position of this distance keeper can be different. Minimum distance between tool and the components on the PCB: 4 mm

7.1.1 Press-in tool

The press-in tool protects the module from being over pressed.

7.1.1.1 Module without thermal interface material

Material requirements for the press-in tool:

- Tool steel grade 21 MnCr 5 with yield strength of 660 MPa and hardness of 330 HB or better.



- Maintenance: Due to inherent contamination from process and product tolerance differences, it is recommended to clean the press-in tool regularly.

The dimension marked with 'x' on the drawing (Figure 15) depends on module height:

- $12.1^{+0.05}$ mm in the case of 12 mm modules
- $13.1^{+0.05}$ mm in the case of 13 mm modules
- $17.1^{+0.05}$ mm in the case of 17 mm modules

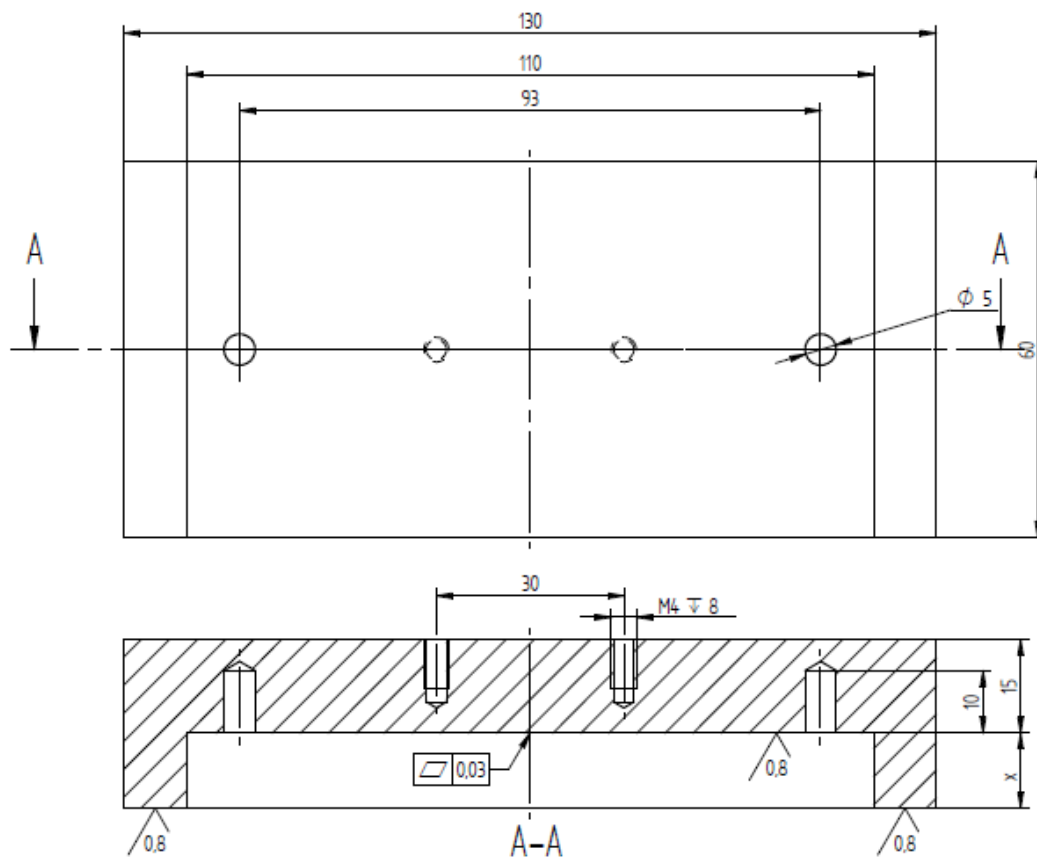

Figure 15: Recommended press-in tool for modules without thermal interface materials



7.1.1.2 Modules with thermal interface material

A unique press-in top tool shown in Figure 16 is needed to prevent significant damage to the phase change material during the press-in process. Small damages (max: $\varnothing 0.6$ mm) are allowed.

Requirements for the press-in tool:

- Material: tool steel grade 21 MnCr 5 with yield strength of 660 MPa and hardness of 330 HB or better.
- Maintenance: Due to inherent contamination from process and product tolerance differences, it is recommended to clean the press-in tool regularly. The desired cleaning interval is once every 100 modules with soft wipes soaked in Isopropyl alcohol.

The dimension marked with 'x' on the drawing (Figure 16) is depends on module height:

- $12.1^{+0.05}$ mm in the case of 12 mm modules
- $13.1^{+0.05}$ mm in the case of 13 mm modules
- $17.1^{+0.05}$ mm in the case of 17 mm modules

For more information or a 3D model please contact your local sales manager.

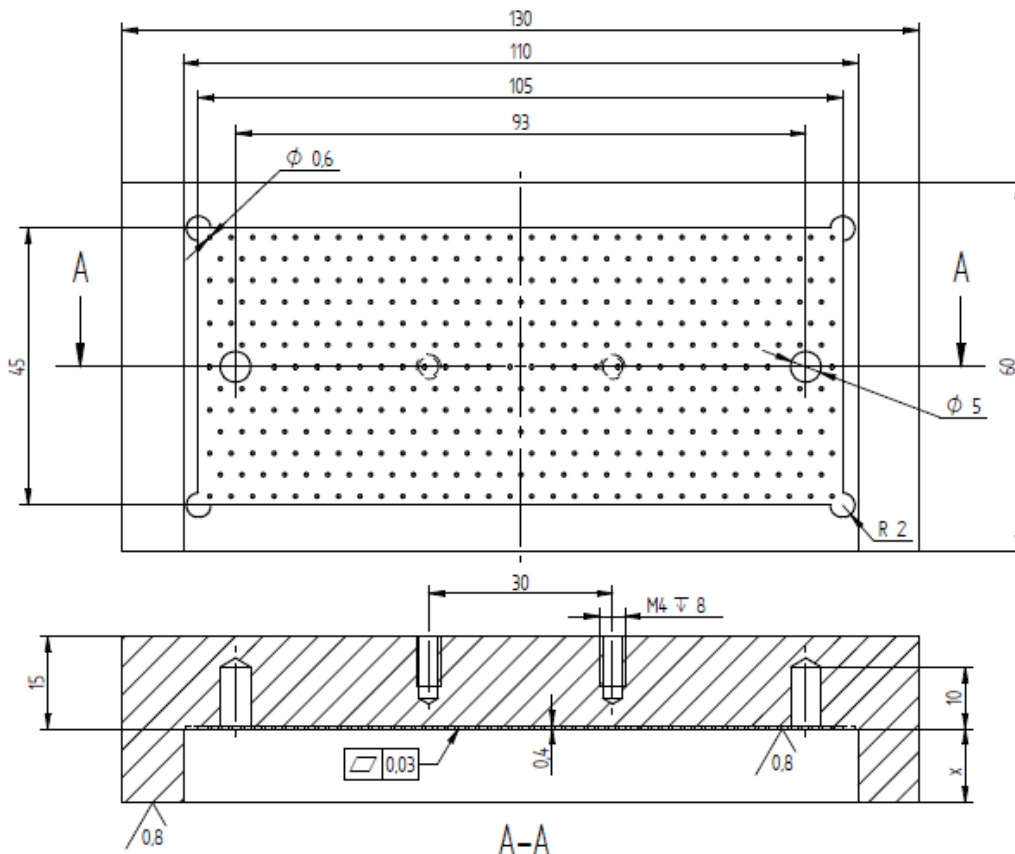

Figure 16: Recommended press-in tool for modules with thermal interface material

7.1.2 Supporting tool

- The supporting tool supports the PCB during the press-in process. The size and position of the holes and cut-outs depends on the components on the PCB.
- Figure 17 shows the recommended hole and cut-out dimensions for the Press-fit pins. The recommended diameter of the holes / cut-outs for the pins in the supporting tool is between 1.7 mm and 4 mm (depending on the positioning accuracy). The minimal supporting place around the pin is 2 mm. If the pins are close to each other then it is possible to make a lengthwise cut-out for more pins as well (the min. distance of PCB components from the PCB pinhole should also be considered here). It is necessary to position the PCB and the module as well. The depth of the cut-outs for the pins is 6 mm.
- The module can be positioned with pins from the bottom tool through the fixing holes of the modules.
- Material of the supporting tool: POM (Polyoxymethylene) ESD proof or any metal alloy.
- The thickness of the supporting tool has to be at least 20 mm.

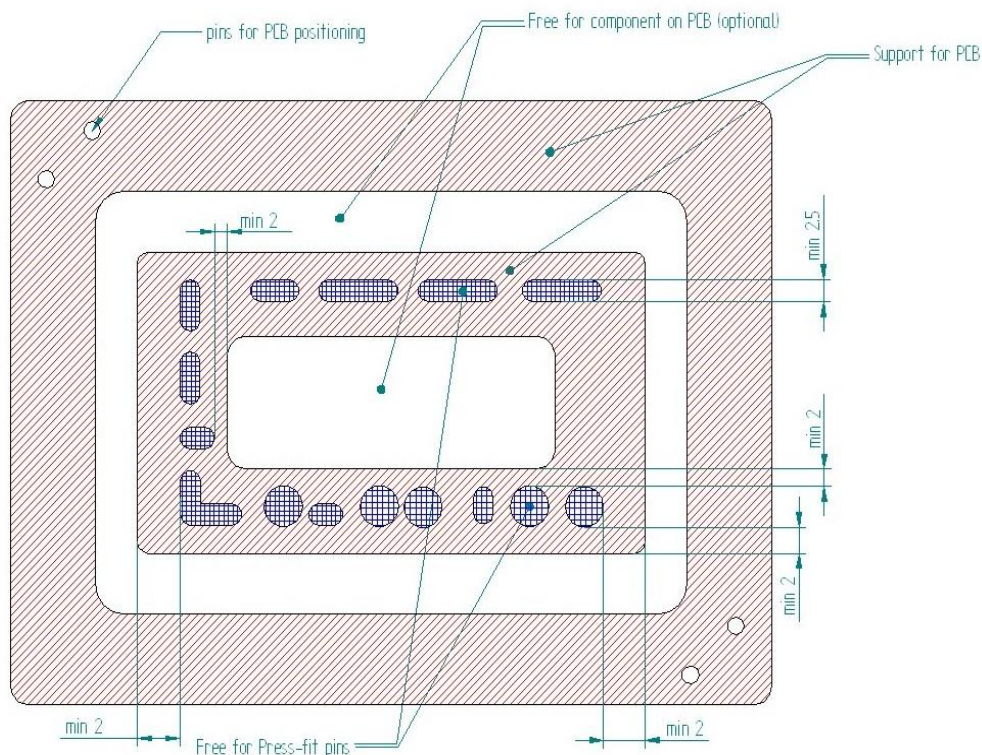

Figure 17: The recommended hole and cutout dimensions for supporting tool

7.2 Press-in process parameters

The total press-in force depends on the number of the pins the hole-diameter and the plating (type/quality) of the PCB.

- Press-in force: 70 N/pin to 160 N/pin
- Press-in speed: 5 mm/s to 10 mm/s

7.2.1 The basic requirement for the press in process

The Press-fit pins have to be pressed to the correct depth into the holes of the PCB. The center of the Press-fit zone has to be at least 0.5 mm below the top surface and at least 0.5 mm above the bottom surface of the PCB. (Figure 18).

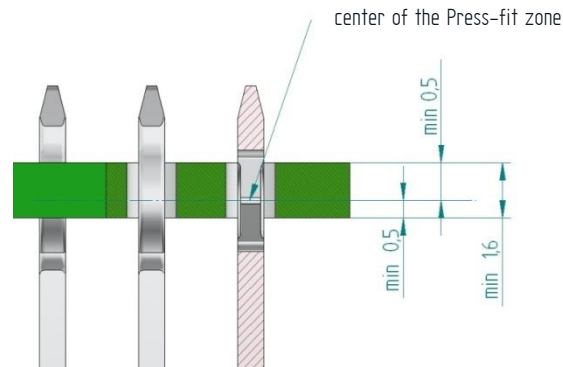

Figure 18: Press-in depth in PCB

This condition is automatically fulfilled with the use of the recommended press-in tool. Figure 14 shows the closed press-in tool with the module.

7.3 Process control parameters

If the press machine is equipped with the possibility to record the force-stroke values during the process, the following quality relevant values should be taken into consideration. Figure 19 shows a normal press-in diagram.

Three different sections can be seen on the diagram:

- First raising section (blue): The Press-fit zones slide into the holes and deform to fit in the holes. This section ends with a local maximum.
- Second section (green): The pin slides in the holes to reach the final position. The centre of the Press-fit zones are inside the holes and do not deform any longer. This section ends with a local minimum.
- Second raising section (red): press-in tool touches the PCB and the sliding of the pins is stopped. The press-in tool starts to bend the PCB.

The pressing-in has to be stopped at the beginning of the second raising section, not exceeding the actual max force of the first rising section, to avoid damaging the PCB or the deformation of the plastic housing. The press-in force or the motion stroke of the tool has to be controlled to stop at the beginning of the second raising section.

Possible process control parameter settings are as follows:

- The local maximum value (end of blue section) of the force-stroke diagram has to be:
 - higher than 70 N x number of the pins,
 - smaller than 160 N x number of the pins.
- These limits are marked on the diagram. If the press-in force does not fit in the interval defined above, it can indicate faulty plating, or improper diameter of the holes.

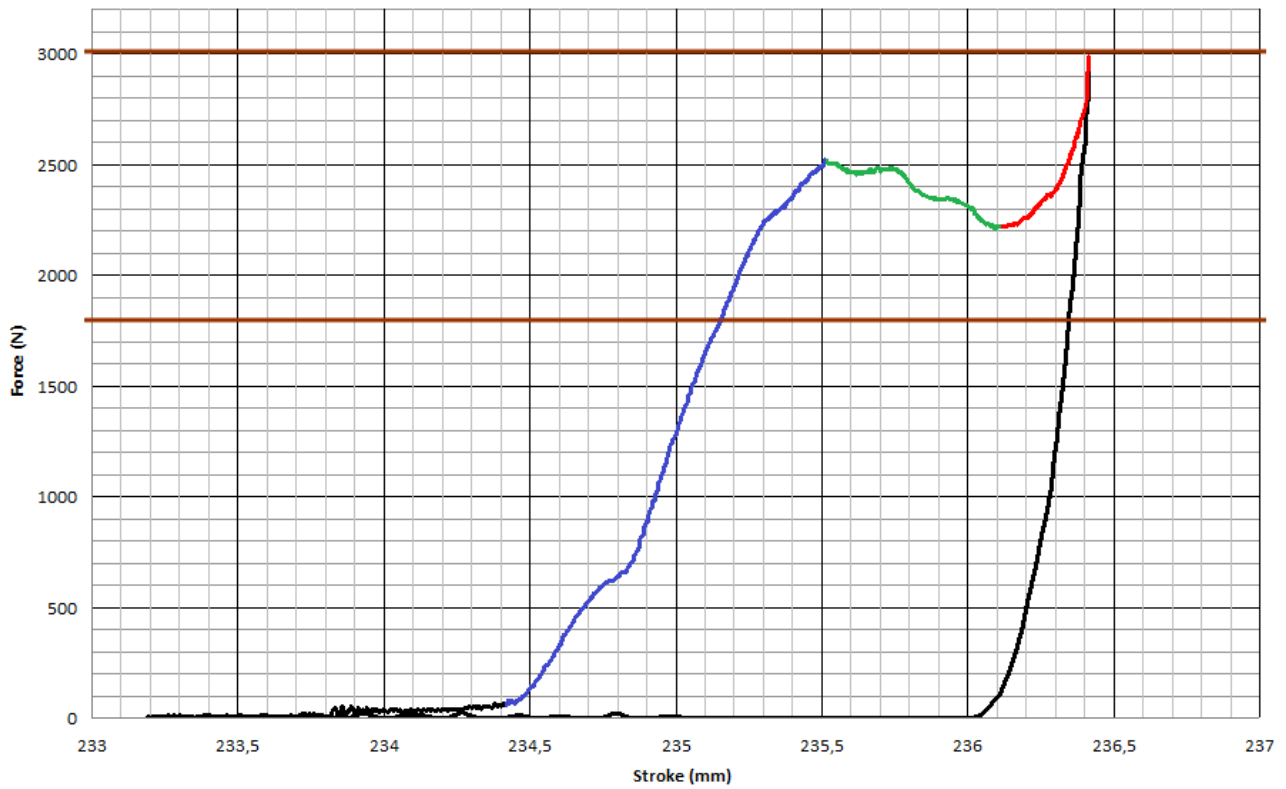

Figure 19: Typical press-in diagram of a 20 pin module



8 Press-out process for modules with Press-fit pins

Please note: In the case an out-pressed module should be used again, it is necessary to solder the module to the PCB because of the remaining deformation of the pins. This is because the Press-fit zone will keep a remaining deformation after the press-out process. An additional press-in cycle will result in low holding forces between the Press-fit pin and the PCB hole. Additional information for the annular ring can be found in section 2.3.

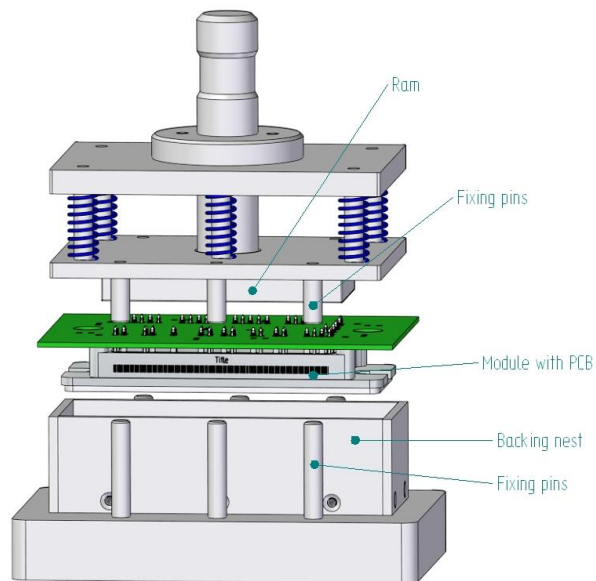

Figure 20: Exploded view of the press-out tool

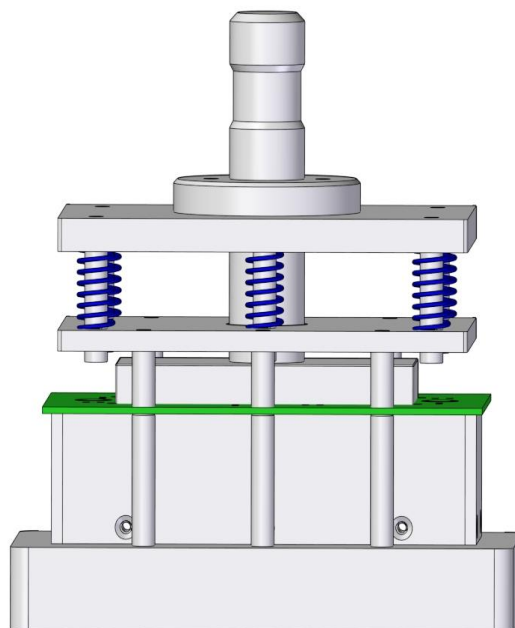

Figure 21: Working position of the press-out tool



8.1 Press-out tool

The specific tool to disassemble the modules from the PCBs has two parts similar to the press-in tool. The lower part serves as a backing for the PCB. It has a backing nest and supporting pins. It is important that the backing has to be as close as possible to the sides of the module. The supporting pins are in line with the fixing pins of the upper part. There may be components mounted to the PCB in the area of the backing. It is possible to cut out the nest in this case.

The upper part consists of two pressing plates that are connected by springs. The pins on the lower plate serve to fix the PCB. With the aid of these parts, the bending of the PCB can be prevented during pressing.

The ram fastened to the upper plate is designed according to the positions of the parts on the PCB and the layout of the pins.

It is not possible to press the module out with a flat plate if the PCB is thicker than 2.5 mm due to the overhang of the pins. In this case, pressing sticks positioned according to the pin layout are necessary.

- Recommended spring force: 25 N/mm
- Recommended number of springs: 4 Pieces

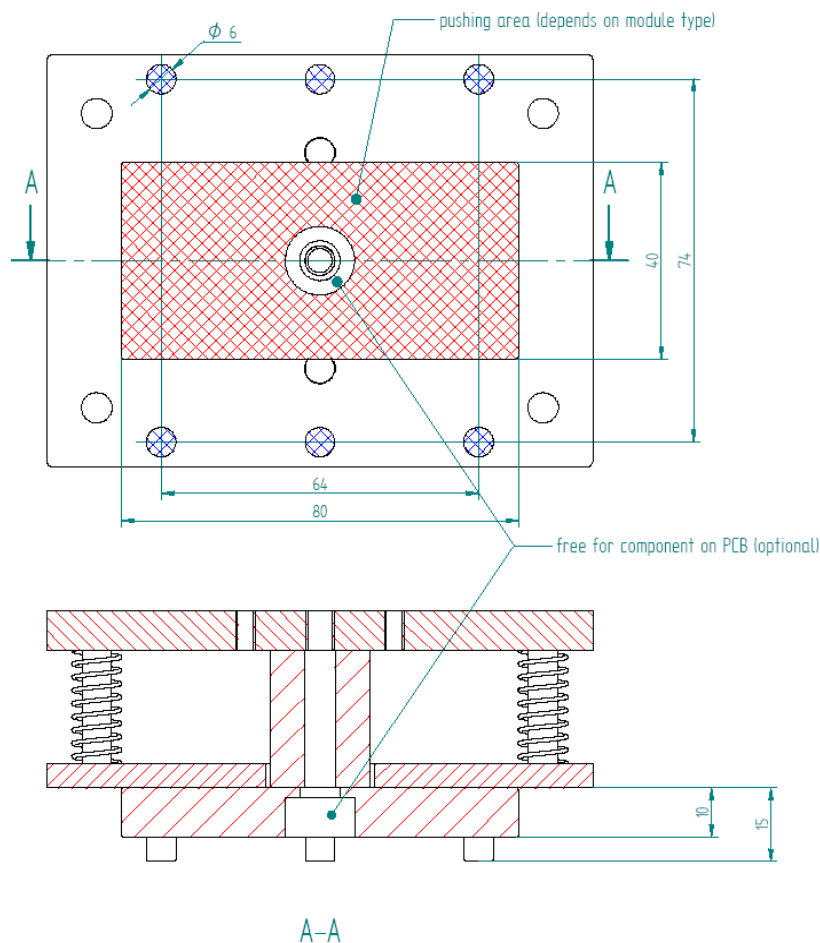

Figure 22: Recommended dimensions of the upper tool



8.2 Press-out process characteristics

After inserting the module into the nest, the downward moving press fixes the PCB with the lower plate through the springs. The pins are pressed through by the onward moving pressing ram.

Figure 24 shows a typical force-distance diagram of the press-out process for a 20 pin module. It is typical for this curve that a characteristic peak appears which indicates the breaking of the cold welded connection.

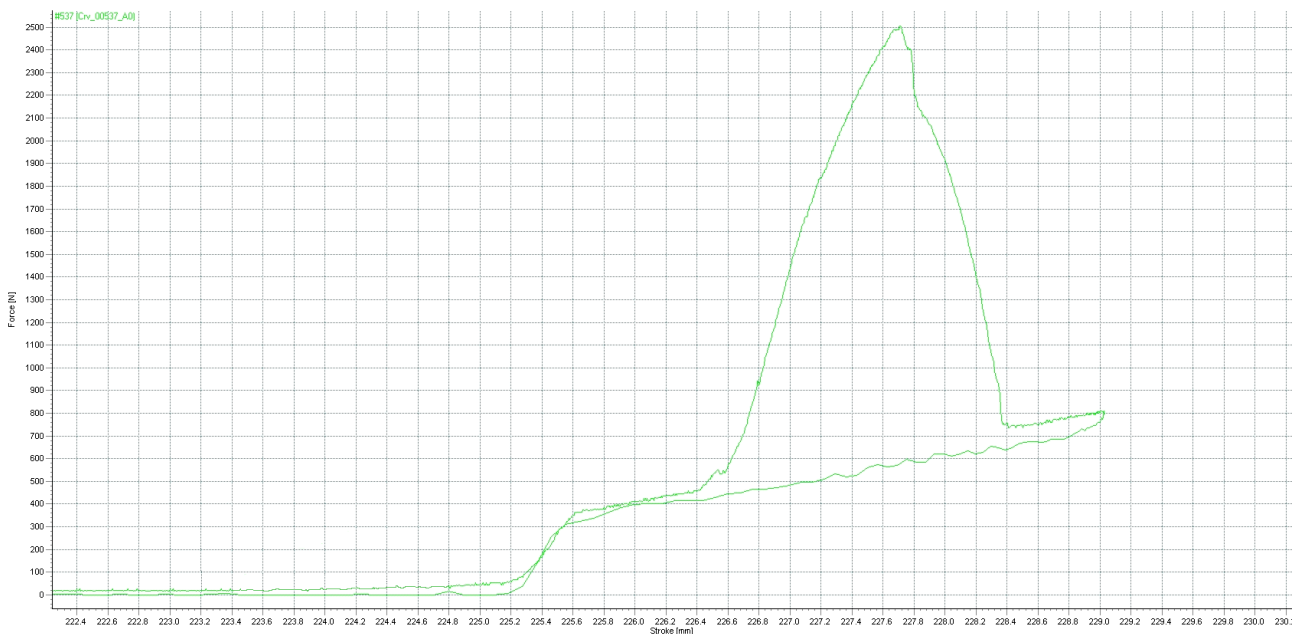

Figure 24: Force-path diagram of the press-out process

8.2.1 Press-out process parameters

- Press-out force: Higher than 40 N/pin
- Press-out speed: 2 mm/s to 5 mm/s

8.3 Disassembling by hand

If the Press-fit zone is overlapped by the PCB in such a way that the spring-end is out of the PCB, the disassembling is possible hand pliers. The cutting should be done in such a way that the cutting edge is under the area where the two parts of the Press-fit zone join shown as level 'A-A' in Figure 25. After clipping away all of the Press-fit zones, it is possible to remove the module from the PCB.

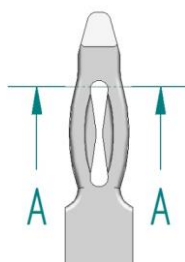

Figure 25: Cutting edge



9 Mounting of modules with solder pins

9.1 Modules with 4 towers

- for minimum overhang of pins IPC-A-610E standard and module datasheet drawing should be considered

9.1.1 Using screws to fix the module to the PCB

- Insert the module pins into the PCB
- Fix the module to the PCB with 4 screws by the towers before soldering. (for screws min. $\varnothing 2.8$ mm hole is needed on PCB)
- Screw type BN82428, $D = 2.5$ mm and $L = 6$ mm with a mounting torque of 0.4 Nm.
- Recommendation for spacer:
 - not necessary to use surrounding the module
 - general heights can be seen in section 2.5

9.1.2 Using soldering jig (without using screws)

- Insert the module pins into the PCB
- Fix the module to the PCB with soldering jig before soldering
- Use spacers also surrounding the module with their height depending on the solder jig dimensions.

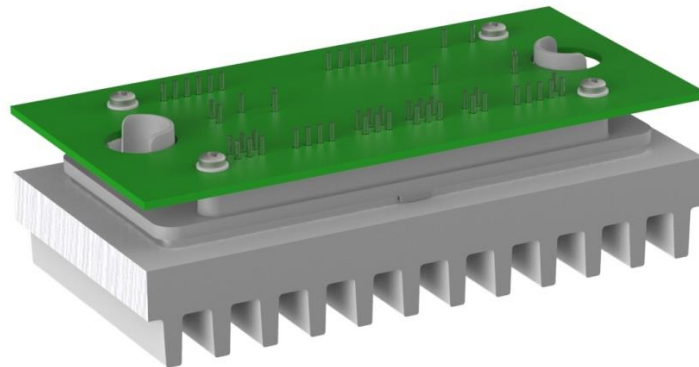

Figure 26: Assembly illustration

10 Recommendation for soldering

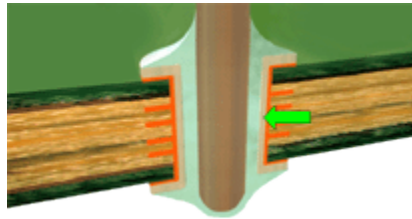

Figure 27: Plated through hole, good soldering

Plated through holes should exhibit a vertical solder fill of 75 %, with a fully formed fillet on the solder side and evidence of 75 % wetting on the component side lead, barrel and pad.

10.1 Wave soldering of modules with solder pins

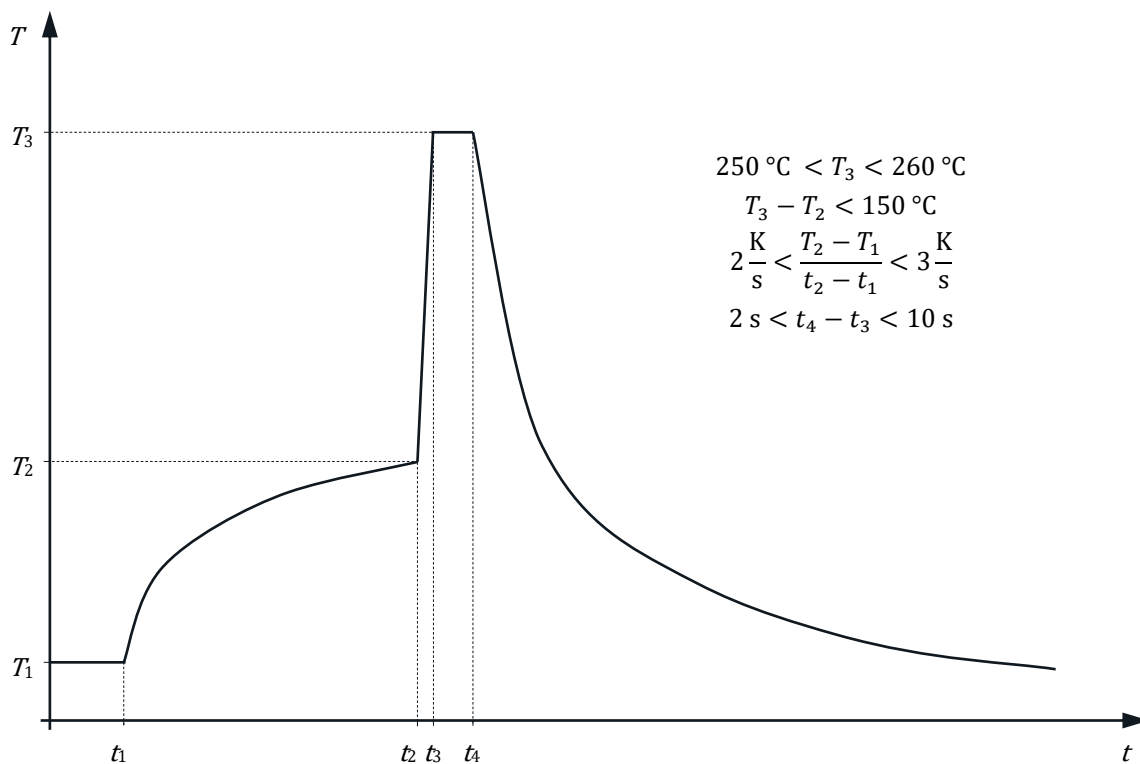

Figure 28: Typical profile for wave soldering

Soldering of certain modules with Press-fit pins is also possible using the wave soldering process. Wave soldering cannot be performed on all type of Press-fit modules.

10.2 Hand soldering parameters

- Max. solder iron temperature: 350 °C
- Max. contact time with component lead: 10 s
- Number of heat cycles: 3



11 ESD protection

Modules are sensitive to electrostatic discharge which can damage or destroy sensitive semiconductors. All modules are ESD protected in the shipment box by semi conductive plastic trays. During the handling and assembly of the modules it is recommended to wear a conductive grounded wrist band and ensure a conductive grounded working place.

The modules have the following ESD sensitivity levels according the ESD Association classification:

ESD STM5.1-1998 Human Body Model:	Class 0
ESD STM5.2-1999 Machine Model:	Class M1
ESD STM5.3.1-1999 Charged Device Model:	Class C1

Please take into consideration the following standards for handling electrostatic-sensitive devices: EN61340-5-1, ANSI S20.20

12 Environmental conditions

The modules can be subjected to environmental conditions characterized by the following classes:

Storage:	1K2 / 1B1 / 1C1 / 1S2 / 1M2
Transportation:	2K2 / 2B1 / 2C1 / 2S1 / 2M2*

These classes are defined in the IEC 60721-3-1 and IEC 60721-3-2 standards. The modules with wire pins have 1 year shelf life and the modules with Press-fit pins have 2 years shelf life with the given storage conditions.

Flammability classification of the plastic material for *flow* 2 packages are V-0 and 5-VA (self-extinguishing, no dripping of flaming particles) according to UL 94, IEC 60695-11-10 and IEC 60695-11-20 test methods.

12.1 Parameters of environment classes

The parameters detailed below are for informative purposes only. This section does not substitute the above mentioned standards. Please read the IEC 60721-3-1 and IEC 60721-3-2 standards for the description of the environment classes.

12.1.1 Climatic conditions

1K2

Air temperature:	5 °C to 40 °C
Humidity:	5 % to 85 % RH but max. 1 g/m ³ to 25 g/m ³ absolute
Rate of change of temperature:	0.5 °C/min
Air pressure:	70 kPa to 106 kPa
Solar radiation:	700 W/m ²
Movement of surrounding air:	1 m/s
Condensation:	No
Precipitation:	No
Water from other sources than rain:	No



Formation of ice and frost:	No
2K2	
Temperature:	-25 °C to 60 °C
Change of temperature air/air:	±25 °C
Relative humidity not combined with rapid temperature changes:	max. 75 % (at 30 °C temperature)
Relative humidity combined with rapid temperature changes:	No
Low air pressure:	70 kPa
Change of air pressure:	No
Solar radiation:	700 W/m ²
Movement of surrounding air:	No
Precipitation:	No
Heat radiation:	No
Water from other sources than rain:	No
Wetness:	No

12.1.2 Biological conditions

1B1

Flora and fauna: Negligible

2B1

Flora and fauna: No

12.1.3 Chemically active substances

1C1

Sea and road salts:	No (Salt mist may be present in sheltered locations of coastal areas.)
Sulphur dioxide:	0.1 mg/m ³
Hydrogen sulphide:	0.01 mg/m ³
Chlorine:	0.01 mg/m ³
Hydrogen chloride:	0.01 mg/m ³
Hydrogen fluoride:	0.003 mg/m ³
Ammonia:	0.3 mg/m ³
Ozone:	0.01 mg/m ³
Nitrogen oxides:	0.1 mg/m ³ (Expressed in equivalent values of Nitrogen dioxide.)

2C2

Sea salts:	none
Sulphur dioxide:	0.1 mg/m ³
Hydrogen sulphide:	0.01 mg/m ³
Nitrogen oxides:	0.1 mg/m ³ (Expressed in the equivalent values of Nitrogen dioxide.)



Ozone:	0.01 mg/m ³
Hydrogen chloride:	0.1 mg/m ³
Hydrogen fluoride:	0.003 mg/m ³
Ammonia:	0.3 mg/m ³

12.1.4 Mechanically active substances

1S2

Sand:	30 mg/m ³
Dust (suspension):	0.2 mg/m ³
Dust (sedimentation):	1.5 mg/(m ² h)

2S1

Sand in air:	No
Dust (sedimentation):	No

12.1.5 Mechanical Conditions

1M2

Stationary vibration, sinusoidal

Frequency range:	2 Hz to 9 Hz
displacement amplitude:	1.5 mm
Frequency range:	9 Hz to 200 Hz
peak acceleration:	5 m/s ²

Non stationary vibration, including shock

Shock response spectrum type L	
peak acceleration:	40 m/s ²

Static load: 5 kPa

2M2

Stationary vibration sinusoidal

Frequency range:	2 Hz to 9 Hz
displacement amplitude:	3.5 mm
Frequency range:	9 Hz to 200 Hz
peak acceleration:	10 m/s ²
Frequency range:	200 Hz to 500 Hz
peak acceleration:	15 m/s ²

Stationary vibration, random

Acceleration	
spectral density:	1 m ² /s ³
Frequency range:	10 Hz to 200 Hz
and	
Acceleration	
spectral density:	0.3 m ² /s ³



Frequency range: 200 Hz to 2000 Hz

The later range can be neglected transporting with vehicles with high damping.

Non stationary vibration, including shock

Shock response spectrum type I.

peak acceleration: 100 m/s²

and

Shock response spectrum type II.

peak acceleration: 300 m/s²

*Free fall:

Weight and drop height deviate from 2M2

Tested acc. to internal standard: F23047-A1004-S000-01-76

Specimen Weight [kg]	Drop Heights [mm]	
	Standard Level	Extra Level
up to 9,5 kg	460	760
over 9,5 to 18,6 kg	310	610
over 18,6 to 27,7 kg	200	460
over 27,7 kg	200	310
Number of Drops	3	7

Toppling: Around any of the edges.

Rolling, pitching

Angle: ±35°

Period: 8 s

35° may occur for short time periods but 22.5° may persist permanently.

Acceleration 20 m/s²

Static load: 10 kPa



13 Handling of trays

The modules are transported in layer of trays and every layer has to be rotated on each other by 180° to guarantee that all the modules are safe. This is also valid any time after unpacking. 32. Figure shows the trays in wrong and in good positioning.

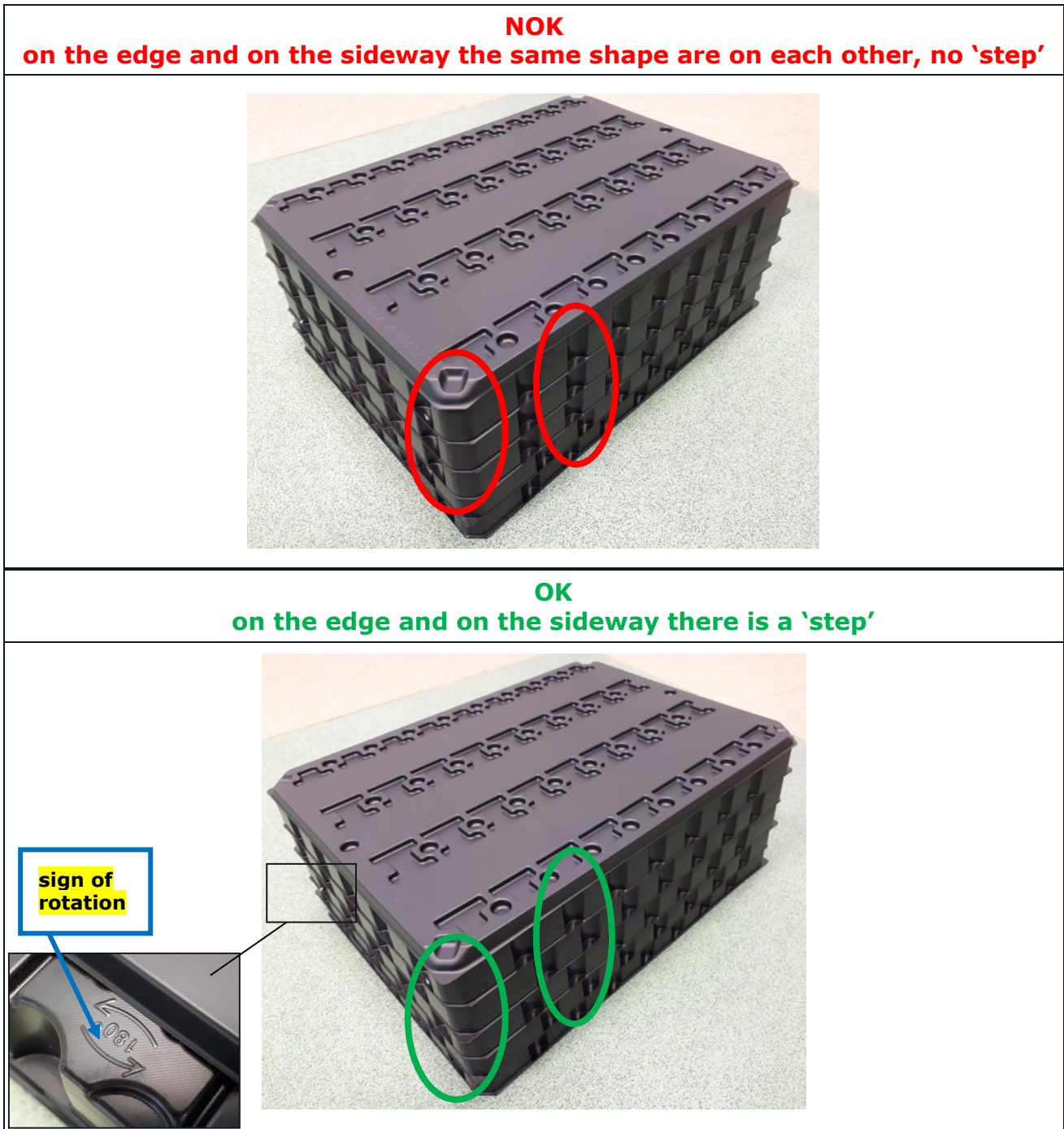

Figure 29: Layer of trays



Vincotech

14 Disclaimer

The information and recommendations in this document are based on standards and common engineering practices. Customer specific applications and specifications may require additional processes and tests that may supersede those recommended in this document.