

TOP VIEW WITHOUT PCB

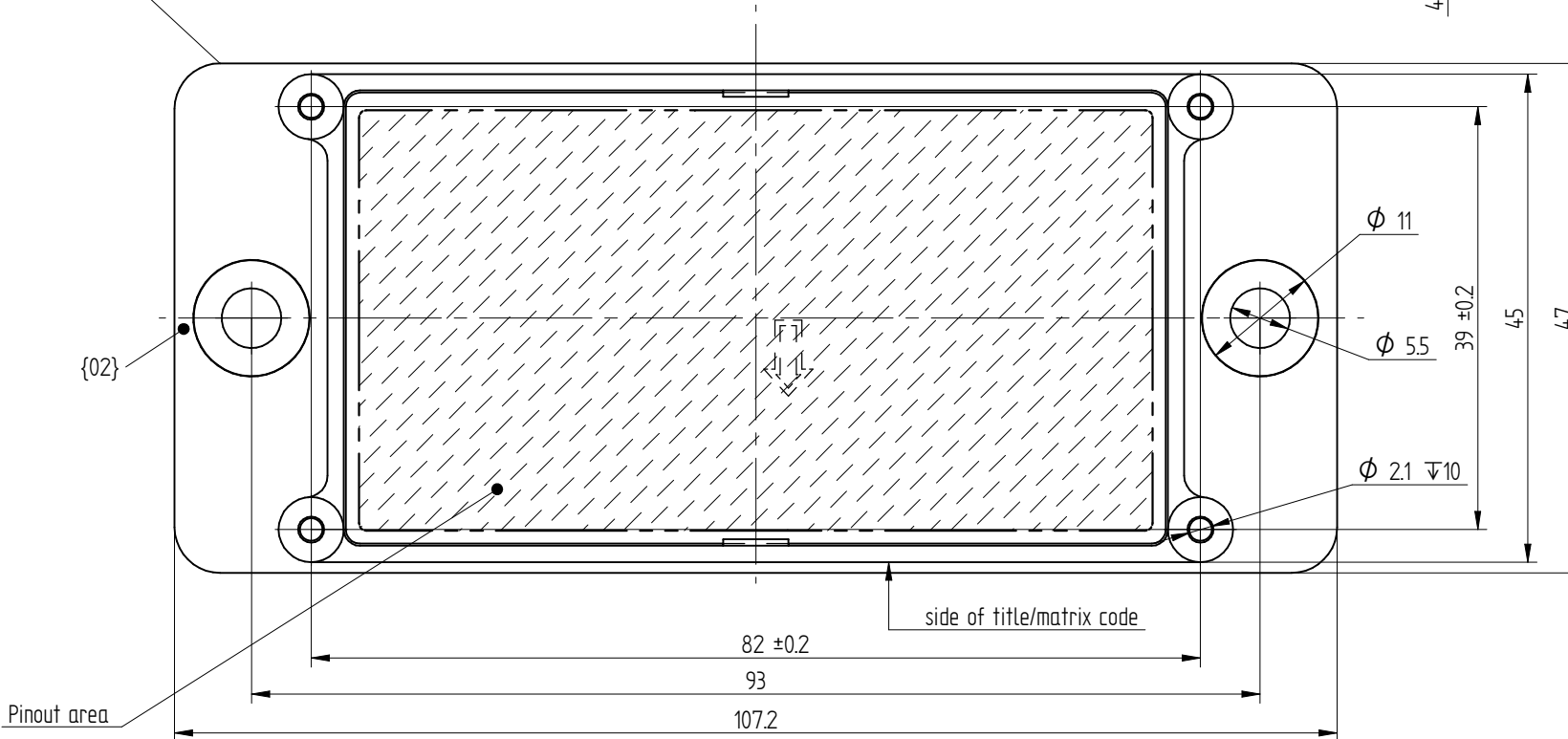

PCB specification according to the actual handling instruction document  
Refer to the module datasheet for actual pinout and 3D-CAD model

02	24.09.2018	closed "U"-form; lead-in tab	Zs. Gyimóthy	Géczy M.	Package Drawing	View scale 1,5:1		
01	11.02.2015	Initial release	T. Gyetvai	Zs. Gyimóthy				
Rev.	Date	Alteration	Designed	Approved				
<b>General tolerances ISO 2768 - m , K</b>			<b>Ps A4</b>		 Vincotech	Flow2-4T17-*-PD Page 1/1		
<b>Linear dimensions</b>		x < 0,5 ± 0,05	0,5 ≤ x < 6 ± 0,1	6 ≤ x < 30 ± 0,2			30 ≤ x < 120 ± 0,3	120 < x ± 0,5
<b>Chamfers, radii</b>		x < 0,3 ± 0,05	0,3 ≤ x < 0,5 ± 0,1	0,5 ≤ x < 3 ± 0,2			3 ≤ x < 6 ± 0,5	6 < x ± 1
<b>References</b>		Inspectional dim:	Revision number (Rev.): *		<b>IP Development</b>	Drawing alteration in revision: {}		