

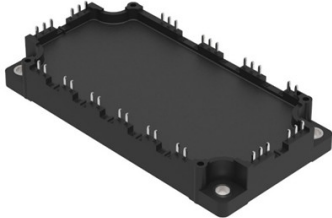
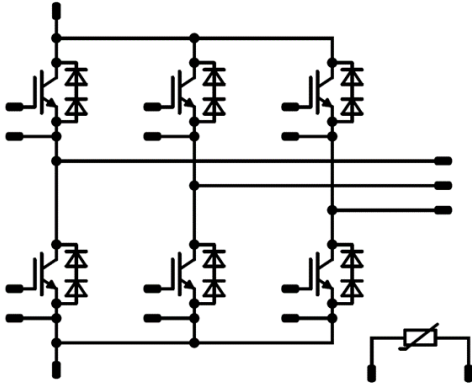

Vincotech

VINcoPACK E3	1200 V / 200 A
<div style="background-color: #eee; padding: 2px; margin-bottom: 5px;">Features</div> <ul style="list-style-type: none"> High speed IGBT4 chip technology Tandem Diode concept for high efficiency, high switching inverter up to 16kHz New SoLid Cover Technology for higher reliability Industry standard housing 	<div style="background-color: #eee; padding: 2px; margin-bottom: 5px;">VINco E3 housing</div> 
<div style="background-color: #eee; padding: 2px; margin-bottom: 5px;">Target applications</div> <ul style="list-style-type: none"> Industrial Drives 	<div style="background-color: #eee; padding: 2px; margin-bottom: 5px;">Schematic</div> 
<div style="background-color: #eee; padding: 2px; margin-bottom: 5px;">Types</div> <ul style="list-style-type: none"> A0-VS126PA200M703-L999F73 	

Maximum Ratings

$T_j = 25\text{ °C}$, unless otherwise specified

Parameter	Symbol	Condition	Value	Unit
Inverter Switch				
Collector-emitter voltage	V_{CES}		1200	V
Collector current	I_C	$T_j = T_{jmax}$ $T_s = 80\text{ °C}$	181	A
Repetitive peak collector current	I_{CRM}	t_p limited by T_{jmax}	600	A
Total power dissipation	P_{tot}	$T_j = T_{jmax}$ $T_s = 80\text{ °C}$	424	W
Gate-emitter voltage	V_{GES}		±20	V
Short circuit ratings	t_{SC}	$V_{GE} = 15\text{ V}$ $V_{CC} = 800\text{ V}$ $T_j = 150\text{ °C}$	10	µs
Maximum junction temperature	T_{jmax}		175	°C



Vincotech

Maximum Ratings

$T_j = 25\text{ °C}$, unless otherwise specified

Parameter	Symbol	Condition	Value	Unit
Inverter Diode				
Peak repetitive reverse voltage	V_{RRM}		1300	V
Continuous (direct) forward current	I_F	$T_j = T_{jmax}$ $T_s = 80\text{ °C}$	99	A
Repetitive peak forward current	I_{FRM}		300	A
Total power dissipation	P_{tot}	$T_j = T_{jmax}$ $T_s = 80\text{ °C}$	270	W
Maximum junction temperature	T_{jmax}		175	°C

Module Properties

Thermal Properties

Storage temperature	T_{stg}		-40...+125	°C
Operation temperature under switching condition	T_{top}		-40...(T _{jmax} - 25)	°C

Isolation Properties

Isolation voltage	V_{isol}	DC Test Voltage* $t_p = 2\text{ s}$	6000	V
		AC Voltage $t_p = 1\text{ min}$	2500	V
Creepage distance			min. 12,7	mm
Clearance			9	mm
Comparative Tracking Index	CTI		> 200	

*100 % tested in production



Vincotech

Characteristic Values

Parameter	Symbol	Conditions					Value			Unit
		V_{GE} [V]	V_{CE} [V]	I_C [A]	T_j [°C]	Min	Typ	Max		

Inverter Switch

Static

Parameter	Symbol	Conditions	V_{GE} [V]	V_{GS} [V]	V_{CE} [V]	V_{DS} [V]	I_D [A]	I_F [A]	T_j [°C]	Min	Typ	Max	Unit
Gate-emitter threshold voltage	$V_{GE(th)}$	$V_{GE} = V_{CE}$					0,0076		25	5,1	5,8	6,4	V
Collector-emitter saturation voltage	V_{CEsat}		15				200		25 125 150	1,78	1,99 2,29 2,37	2,5	V
Collector-emitter cut-off current	I_{CES}		0	1200					25			5	μA
Gate-emitter leakage current	I_{GES}		20	0					25			300	nA
Internal gate resistance	r_g										none		Ω
Input capacitance	C_{ies}	$f = 1$ Mhz	0	25					25		12300		pF
Reverse transfer capacitance	C_{res}										690		
Gate charge	Q_g		15						25		1600		nC

Thermal

Thermal resistance junction to sink	$R_{th(j-s)}$	$\lambda_{paste} = 3,4$ W/mK (PSX)									0,22		K/W
-------------------------------------	---------------	---------------------------------------	--	--	--	--	--	--	--	--	------	--	-----

Dynamic

Parameter	Symbol	Conditions	V_{GE} [V]	V_{GS} [V]	V_{CE} [V]	V_{DS} [V]	I_D [A]	I_F [A]	T_j [°C]	Min	Typ	Max	Unit
Turn-on delay time	$t_{d(on)}$	$R_{gon} = 2$ Ω $R_{goff} = 2$ Ω	±15		600	200	25		25		111		ns
Rise time	t_r						125		125		107		
							150		150		107		
							25		25		15		
Turn-off delay time	$t_{d(off)}$						125		125		205		
							150		150		255		
							150		150		272		
Fall time	t_f	25		25		28							
		125		125		49							
		150		150		65							
Turn-on energy (per pulse)	E_{on}	$Q_{tFWD} = 7,6$ μC $Q_{tFWD} = 13,7$ μC $Q_{tFWD} = 16,9$ μC			600	200	25		25		5,240		mWs
							125		125		8,171		
							150		150		8,979		
Turn-off energy (per pulse)	E_{off}						25		25		5,388		
							125		125		9,291		
							150		150		10,836		



Characteristic Values

Parameter	Symbol	Conditions					Value			Unit
		V_{GE} [V] V_{GS} [V]	V_{CE} [V] V_{DS} [V]	I_C [A] I_D [A]	I_F [A]	T_j [°C]	Min	Typ	Max	

Inverter Diode

Static

Forward voltage	V_F				150	25 125 150		3,31 3,35 3,32	4	V
Reverse leakage current	I_R			1300		25			1,8	μA

Thermal

Thermal resistance junction to sink	$R_{th(j-s)}$	$\lambda_{paste} = 3,4$ W/mK (PSX)						0,35		K/W
-------------------------------------	---------------	---------------------------------------	--	--	--	--	--	------	--	-----

Dynamic

Peak recovery current	I_{RRM}					25 125 150		193 238 253		A
Reverse recovery time	t_{rr}					25 125 150		149 168 335		ns
Recovered charge	Q_r	$di/dt = 14580$ A/ $di/dt = 13800$ A/ $di/dt = 15072$ A/	±15	600	200	25 125 150		7,577 13,703 16,887		μC
Reverse recovered energy	E_{rec}					25 125 150		2,738 4,951 6,391		mWs
Peak rate of fall of recovery current	$(di_{rr}/dt)_{max}$					25 125 150		16943 13081 11186		A/μs

Thermistor

Rated resistance	R					25		5		kΩ
Deviation of R_{100}	$\Delta_{R/R}$	$R_{100} = 493$ Ω				100	-5		+5	%
Power dissipation	P					25		245		mW
Power dissipation constant						25		1,4		mW/K
B-value	$B_{(25/50)}$	Tol. ±2 %				25		3375		K
B-value	$B_{(25/100)}$	Tol. ±2 %				25		3437		K
Vincotech NTC Reference									K	



Inverter Switch Characteristics

figure 1. IGBT

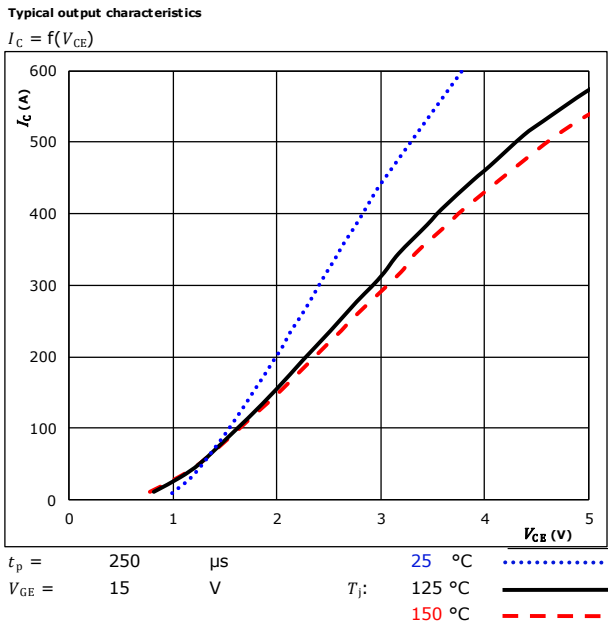

figure 2. IGBT

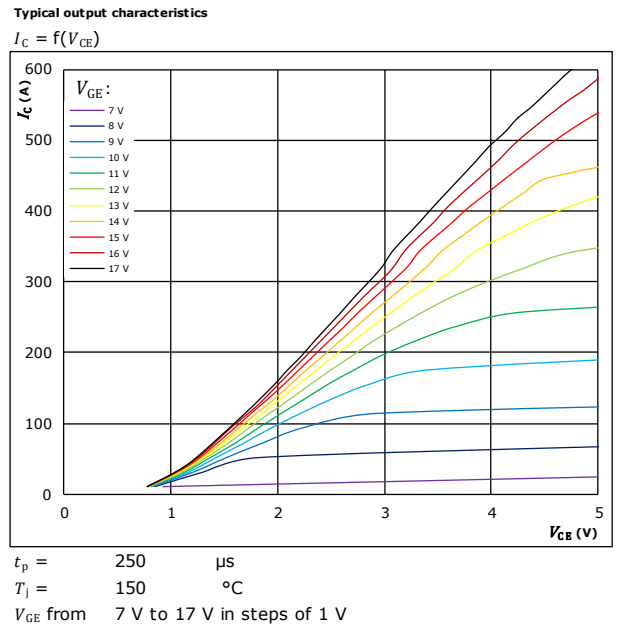

figure 3. IGBT

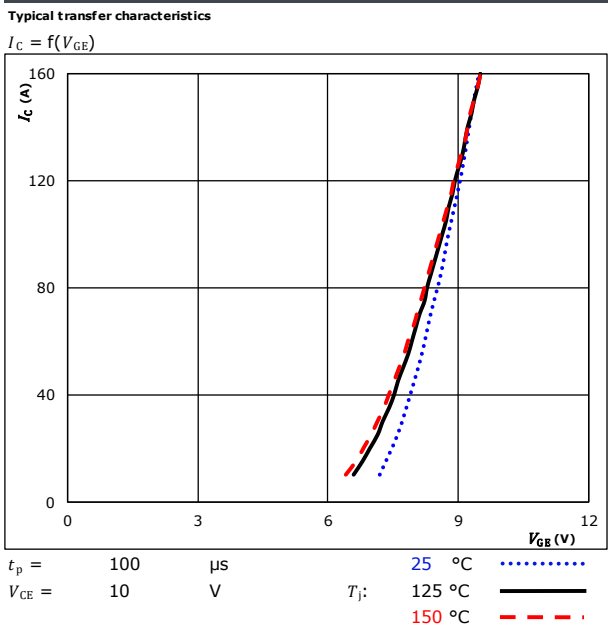
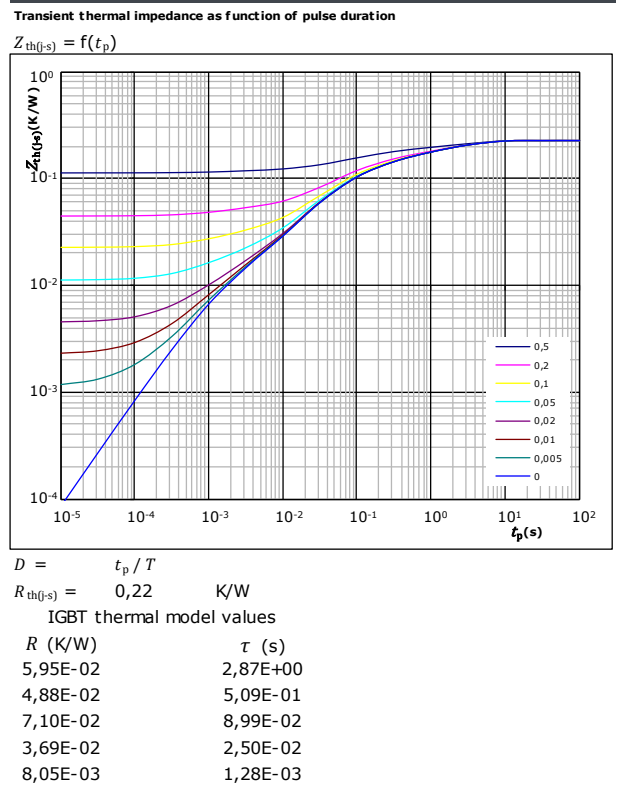

figure 4. IGBT





Vincotech

Inverter Switch Characteristics

figure 5. IGBT

Safe operating area

$$I_C = f(V_{CE})$$

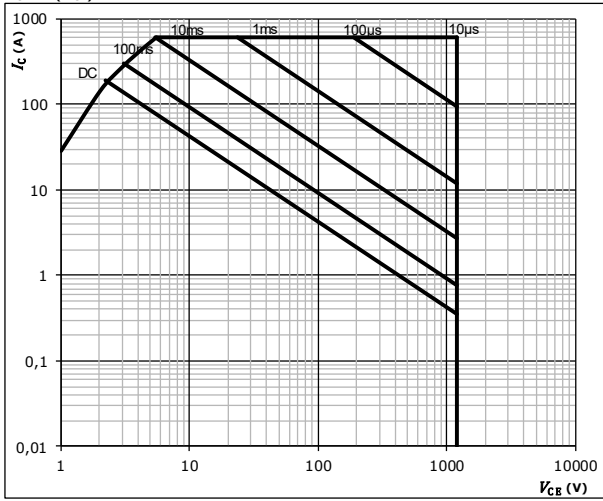

$D =$ single pulse
 $T_s =$ 80 °C
 $V_{GE} =$ 0 V
 $T_j = T_{jmax}$



Inverter Diode Characteristics

figure 1. FWD

Typical forward characteristics

$$I_F = f(V_F)$$

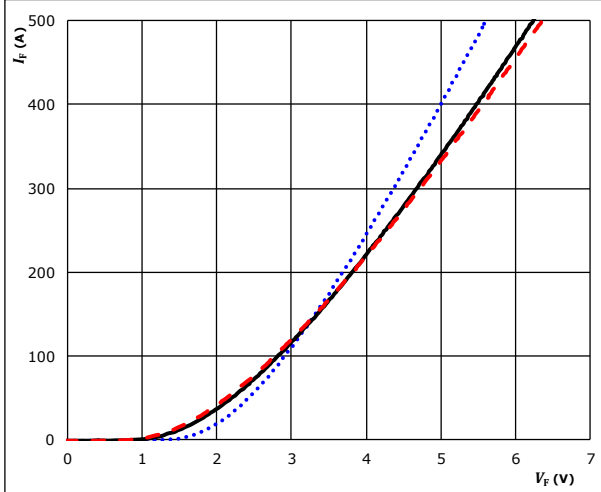

$t_p = 250 \mu s$
 T_j : 25 °C
 125 °C ———
 150 °C - - - -

figure 2. FWD

Transient thermal impedance as a function of pulse width

$$Z_{th(j-s)} = f(t_p)$$

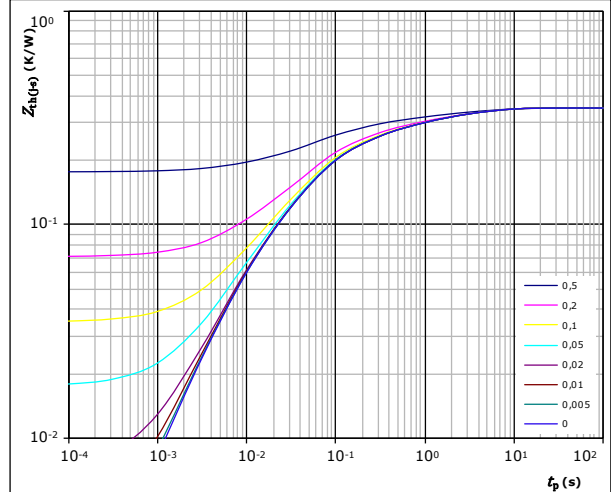

$D = t_p / T$
 $R_{th(j-s)} = 0,35 \text{ K/W}$
 FWD thermal model values

R (K/W)	τ (s)
4,64E-02	3,89E+00
5,87E-02	7,39E-01
8,42E-02	1,56E-01
1,34E-01	4,32E-02
3,50E-02	7,21E-03
-6,58E-03	8,86E-02

Thermistor Characteristics

figure 1. Thermistor

Typical NTC characteristic
as a function of temperature

$$R = f(T)$$

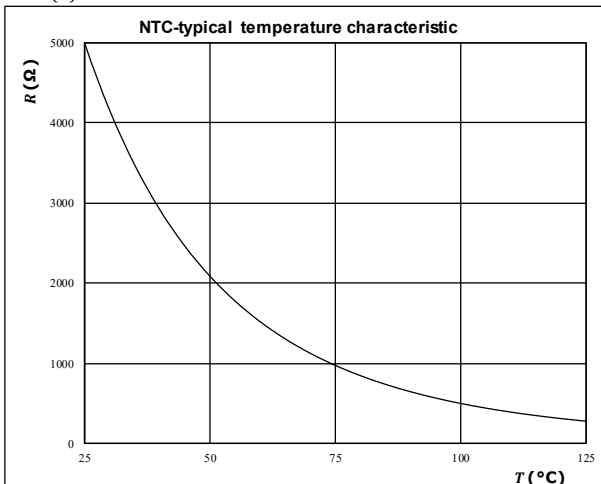



Switching Characteristics

figure 1. IGBT

Typical switching energy losses as a function of collector current

$$E = f(I_C)$$

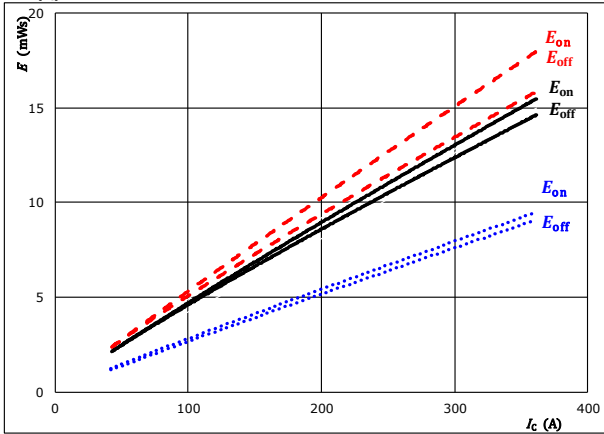

With an inductive load at

$V_{CE} =$	600 V	$T_j =$	25 °C
$V_{GE} =$	±15 V		125 °C
$R_{g(on)} =$	2 Ω		150 °C
$R_{g(off)} =$	2 Ω		

figure 2. IGBT

Typical switching energy losses as a function of gate resistor

$$E = f(R_g)$$

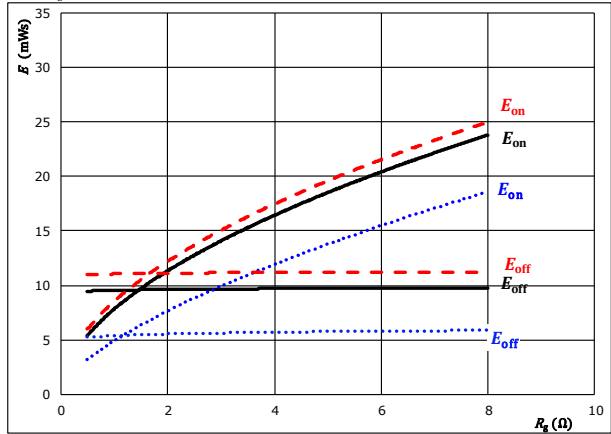

With an inductive load at

$V_{CE} =$	600 V	$T_j =$	25 °C
$V_{GE} =$	±15 V		125 °C
$I_C =$	200 A		150 °C

figure 3. FWD

Typical reverse recovered energy loss as a function of collector current

$$E_{rec} = f(I_C)$$

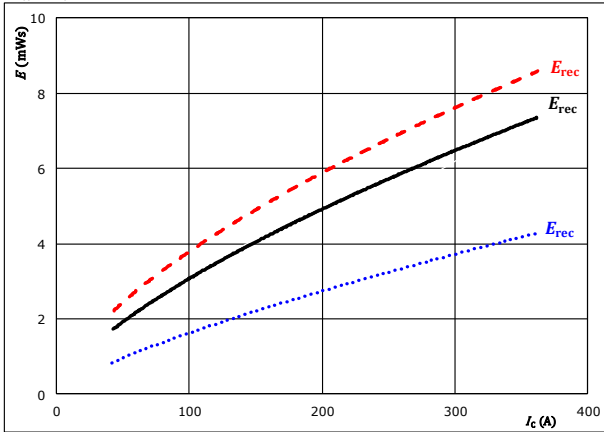

With an inductive load at

$V_{CE} =$	600 V	$T_j =$	25 °C
$V_{GE} =$	±15 V		125 °C
$R_{g(on)} =$	2 Ω		150 °C

figure 4. FWD

Typical reverse recovered energy loss as a function of gate resistor

$$E_{rec} = f(R_g)$$

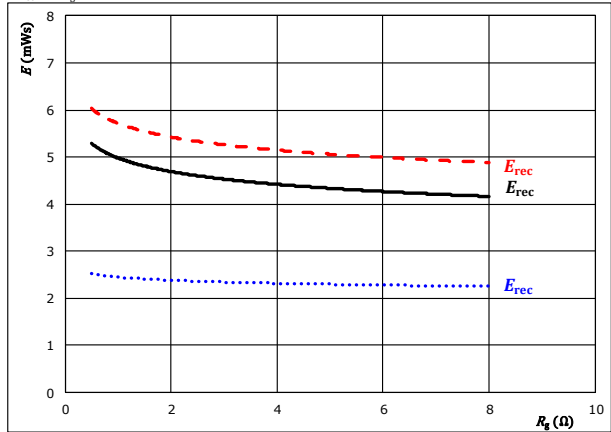

With an inductive load at

$V_{CE} =$	600 V	$T_j =$	25 °C
$V_{GE} =$	±15 V		125 °C
$I_C =$	200 A		150 °C



Switching Characteristics

figure 5. IGBT

Typical switching times as a function of collector current

$$t = f(I_C)$$

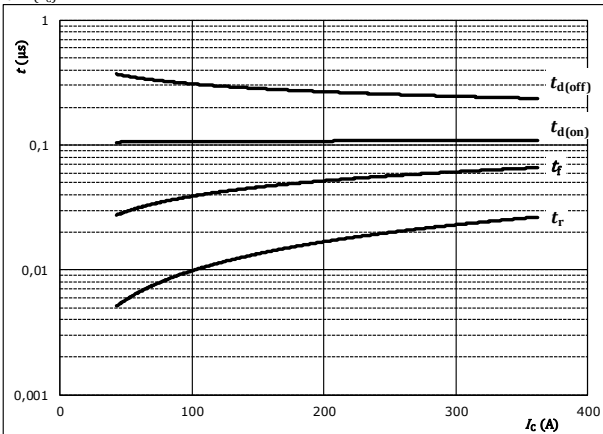

With an inductive load at

$T_j =$	150	°C
$V_{CE} =$	600	V
$V_{GE} =$	±15	V
$R_{gon} =$	2	Ω
$R_{goff} =$	2	Ω

figure 6. IGBT

Typical switching times as a function of gate resistor

$$t = f(R_g)$$

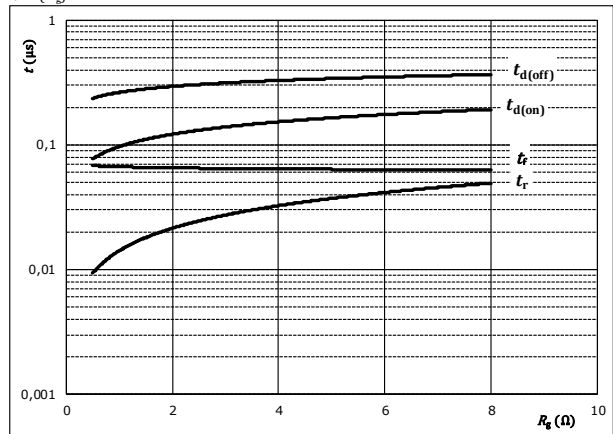

With an inductive load at

$T_j =$	150	°C
$V_{CE} =$	600	V
$V_{GE} =$	±15	V
$I_C =$	200	A

figure 7. FWD

Typical reverse recovery time as a function of collector current

$$t_{rr} = f(I_C)$$

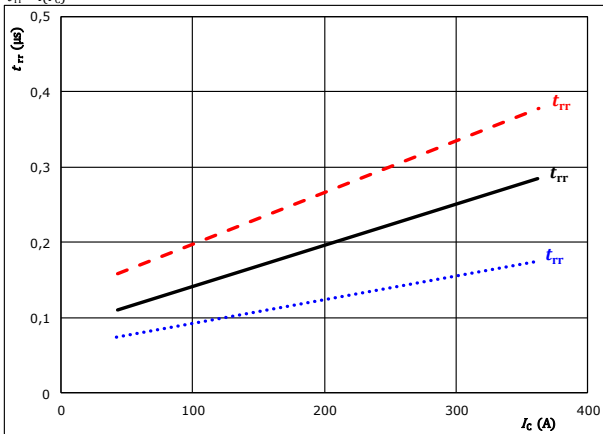

With an inductive load at

$V_{CE} =$	600	V	$T_j:$	25 °C
$V_{GE} =$	±15	V		125 °C	————
$R_{gon} =$	2	Ω		150 °C	- - - -

figure 8. FWD

Typical reverse recovery time as a function of IGBT turn on gate resistor

$$t_{rr} = f(R_{gon})$$

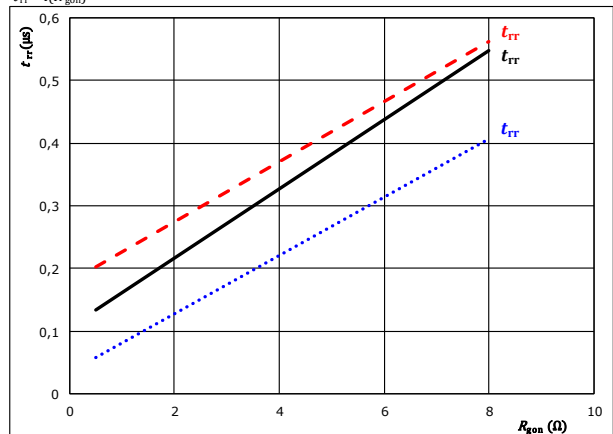

With an inductive load at

$V_{CE} =$	600	V	$T_j:$	25 °C
$V_{GE} =$	±15	V		125 °C	————
$I_C =$	200	A		150 °C	- - - -



Switching Characteristics

figure 9. FWD

Typical recovered charge as a function of collector current

$$Q_r = f(I_c)$$

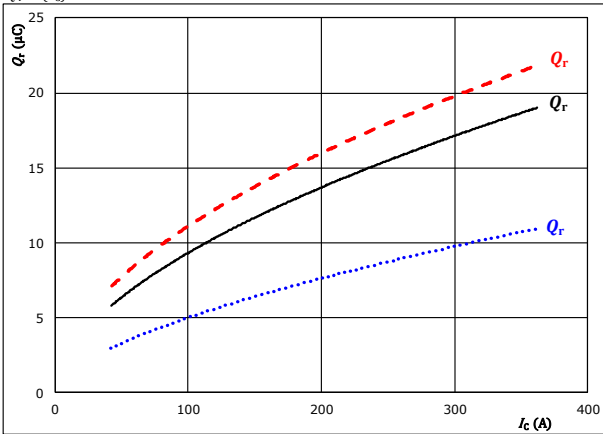

With an inductive load at

$V_{CE} = 600$ V	$T_j: 25$ °C
$V_{GE} = \pm 15$ V	125 °C	————
$R_{gdn} = 2$ Ω	150 °C	-----

figure 10. FWD

Typical recovered charge as a function of IGBT turn on gate resistor

$$Q_r = f(R_{gdn})$$

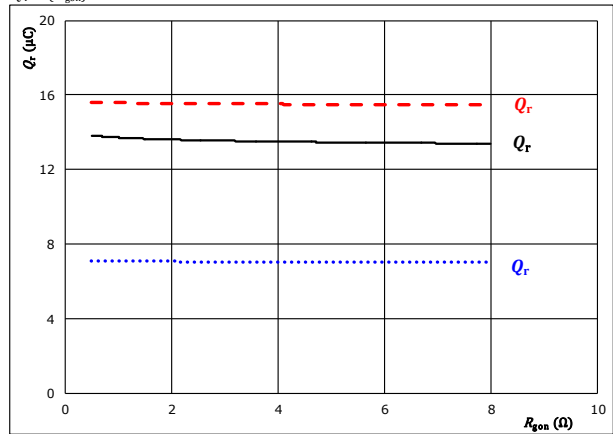

With an inductive load at

$V_{CE} = 600$ V	$T_j: 25$ °C
$V_{GE} = \pm 15$ V	125 °C	————
$I_C = 200$ A	150 °C	-----

figure 11. FWD

Typical peak reverse recovery current current as a function of collector current

$$I_{RM} = f(I_c)$$

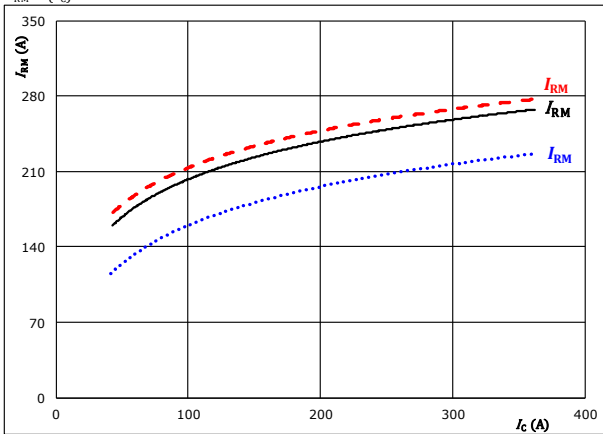

With an inductive load at

$V_{CE} = 600$ V	$T_j: 25$ °C
$V_{GE} = \pm 15$ V	125 °C	————
$R_{gdn} = 2$ Ω	150 °C	-----

figure 12. FWD

Typical peak reverse recovery current as a function of IGBT turn on gate resistor

$$I_{RM} = f(R_{gdn})$$

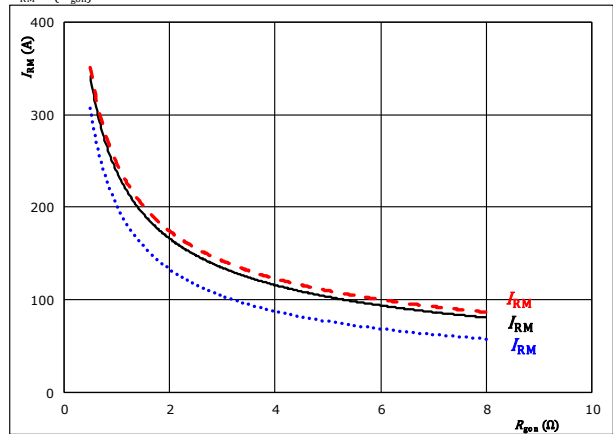

With an inductive load at

$V_{CE} = 600$ V	$T_j: 25$ °C
$V_{GE} = \pm 15$ V	125 °C	————
$I_C = 200$ A	150 °C	-----



Switching Characteristics

figure 13. FWD

Typical rate of fall of forward and reverse recovery current as a function of collector current
 $di_f/dt, di_{rr}/dt = f(I_C)$

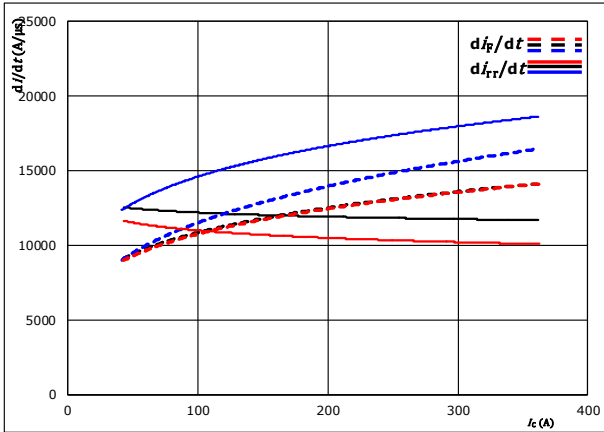

With an inductive load at
 $V_{CE} = 600$ V
 $V_{GE} = \pm 15$ V
 $R_{gon} = 2$ Ω
 $T_j: 25$ °C
 150 °C

figure 14. FWD

Typical rate of fall of forward and reverse recovery current as a function of IGBT turn on gate resistor
 $di_f/dt, di_{rr}/dt = f(R_{gon})$

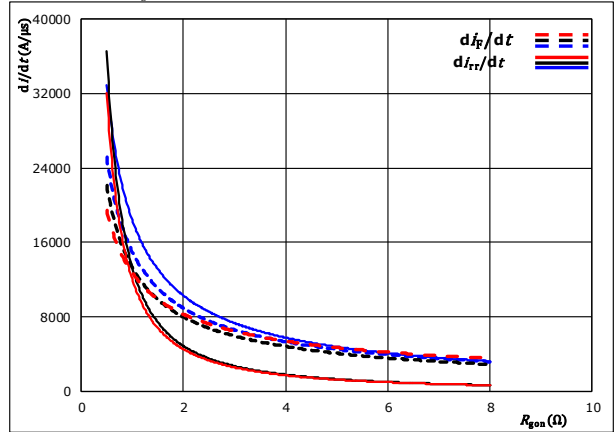

With an inductive load at
 $V_{CE} = 600$ V
 $V_{GE} = \pm 15$ V
 $I_C = 200$ A
 $T_j: 25$ °C
 150 °C

figure 15. IGBT

Reverse bias safe operating area
 $I_C = f(V_{CB})$

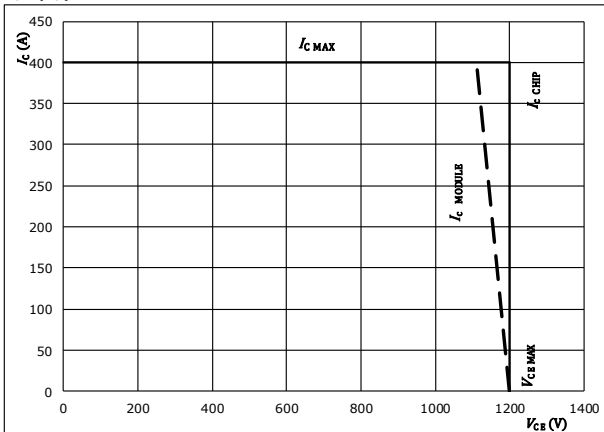

At
 $T_j = 150$ °C
 $R_{gon} = 2$ Ω
 $R_{goff} = 2$ Ω



Switching Definitions

General conditions		
T_j	=	150 °C
R_{gon}	=	2 Ω
R_{goff}	=	2 Ω

figure 1. IGBT

Turn-off Switching Waveforms & definition of t_{doff} , t_{Eoff} (t_{Eoff} = integrating time for E_{off})

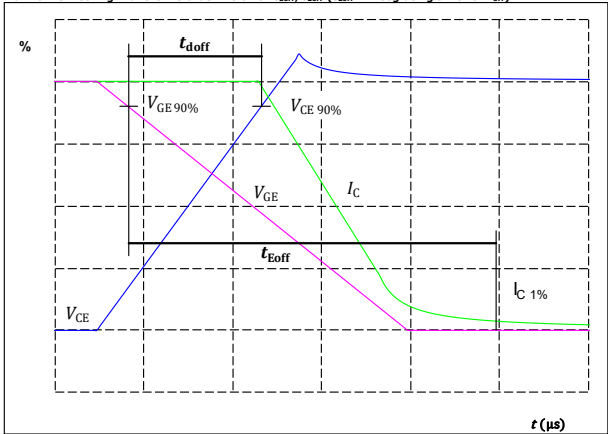

$V_{CE}(0\%) =$	-15	V
$V_{GE}(100\%) =$	15	V
$V_C(100\%) =$	600	V
$I_C(100\%) =$	200	A
$t_{doff} =$	272	ns

figure 2. IGBT

Turn-on Switching Waveforms & definition of t_{don} , t_{Eon} (t_{Eon} = integrating time for E_{on})

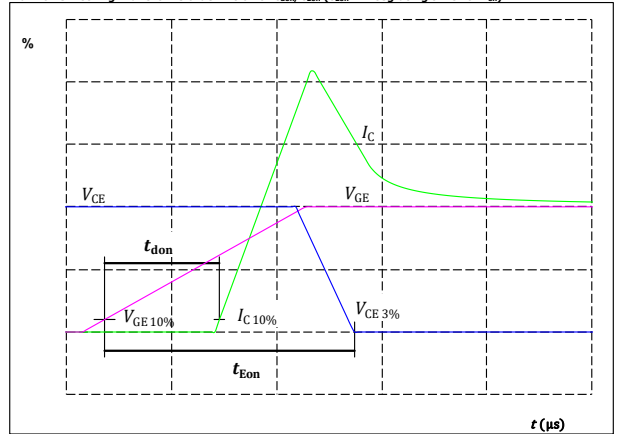

$V_{CE}(0\%) =$	-15	V
$V_{GE}(100\%) =$	15	V
$V_C(100\%) =$	600	V
$I_C(100\%) =$	200	A
$t_{don} =$	107	ns

figure 3. IGBT

Turn-off Switching Waveforms & definition of t_f

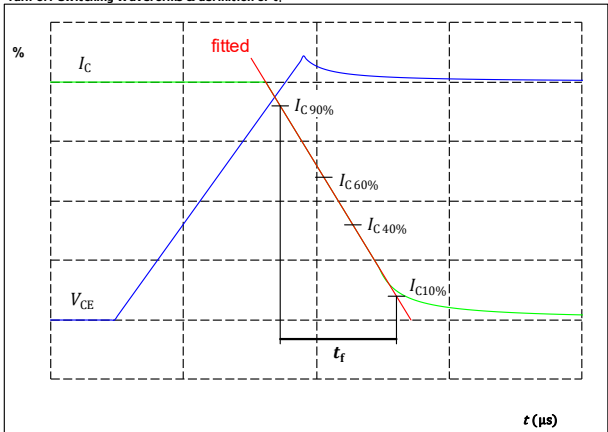

$V_C(100\%) =$	600	V
$I_C(100\%) =$	200	A
$t_f =$	65	ns

figure 4. IGBT

Turn-on Switching Waveforms & definition of t_r

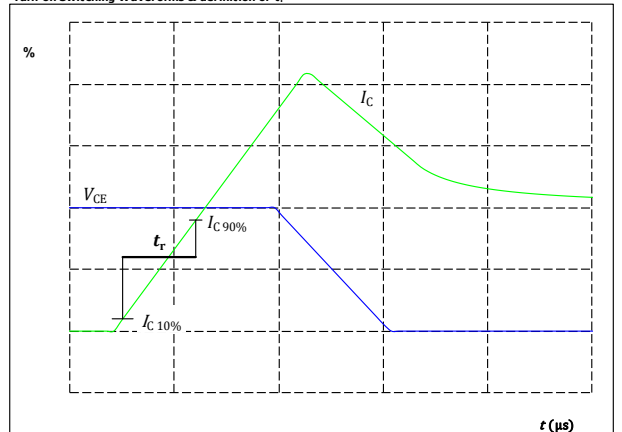

$V_C(100\%) =$	600	V
$I_C(100\%) =$	200	A
$t_r =$	18	ns



Switching Characteristics

figure 5. FWD
Turn-off Switching Waveforms & definition of t_{rr}

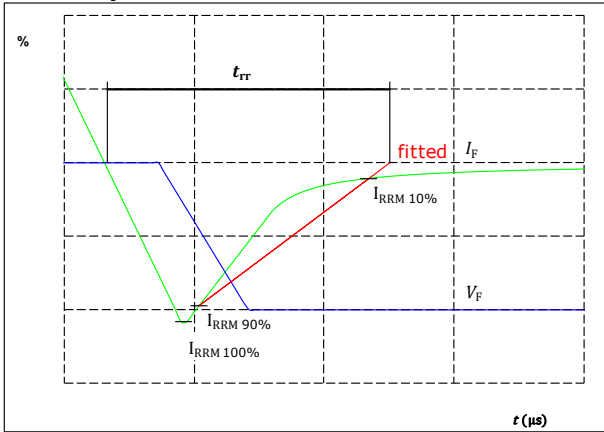

$V_F(100\%) =$	600	V
$I_F(100\%) =$	200	A
$I_{RRM}(100\%) =$	253	A
$t_{rr} =$	335	ns

figure 6. FWD
Turn-on Switching Waveforms & definition of t_{Qr} ($t_{Qr} =$ integrating time for Q_r)

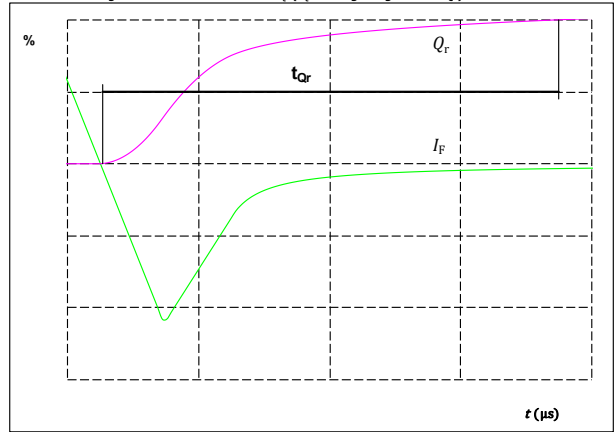

$I_F(100\%) =$	200	A
$Q_r(100\%) =$	17	μC



Vincotech

Ordering Code & Marking								
Version			Ordering Code					
without thermal paste			A0-VS126PA200M703-L999F73					
with thermal paste			A0-VS126PA200M703-L999F73-/3/					
NN-NNNNNNNNNNNN TTTTWW WWYY UL VIN LLLL SSSS			Name		Date code	UL & VIN	Lot	Serial
Text			NN-NNNNNNNNNNNN-TTTTWW		WWYY	UL VIN	LLLL	SSSS
Datamatrix		Type&Ver	Lot number	Serial	Date code			
		TTTTTWW	LLLL	SSSS	WWYY			

Pin table			
Pin	X	Y	Function
1	19,05	0	G12
2	22,86	0	S12
3	34,29	0	G11
4	38,1	0	S11
5	49,53	0	G14
6	53,34	0	S14
7	64,77	0	G13
8	68,58	0	S13
9	80,01	0	G16
10	83,82	0	S16
11	95,25	0	G15
12	99,06	0	S15
13	118,11	15,865	DC-123
14	118,11	19,675	DC-123
15	118,11	23,485	DC-123
16	118,11	34,915	DC+123
17	118,11	38,725	DC+123
18	118,11	42,535	DC+123
19	100,97	58,4	Therm1
20	97,155	58,4	Therm2
21	81,915	58,4	Ph3
22	78,105	58,4	Ph3
23	74,295	58,4	Ph3
24	59,055	58,4	Ph2
25	55,245	58,4	Ph2
26	51,435	58,4	Ph2
27	36,195	58,4	Ph1
28	32,385	58,4	Ph1
29	28,575	58,4	Ph1
30	0	42,535	DC+123
31	0	38,725	DC+123
32	0	34,915	DC+123
33	0	23,485	DC-123
34	0	19,675	DC-123
35	0	15,865	DC-123



Vincotech

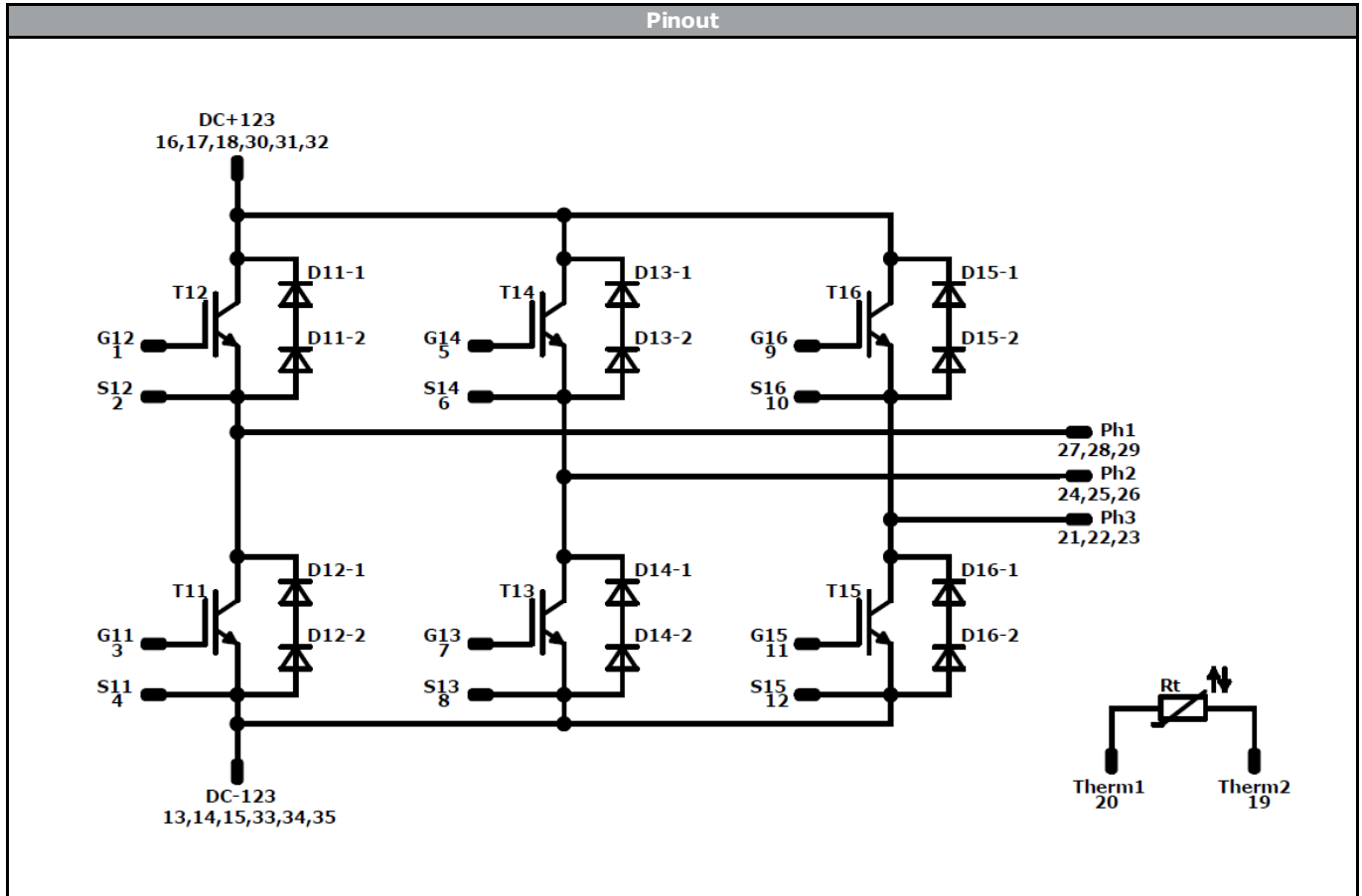

Identification					
ID	Component	Voltage	Current	Function	Comment
T11, T12, T13, T14, T15, T16	IGBT	1200 V	200 A	Inverter Switch	
D11, D12, D13, D14, D15, D16	FWD	1300 V	150 A	Inverter Diode	
Rt	NTC			Thermistor	



Vincotech

Packaging instruction			
Standard packaging quantity (SPQ) 24	>SPQ	Standard	<SPQ Sample

Handling instruction
Handling instructions for VINco E3 packages see vincotech.com website.

Package data
Package data for VINco E3 packages see vincotech.com website.

Document No.:	Date:	Modification:	Pages
A0-VS126PA200M703-L999F73-D1-14	24 Apr. 2019		

DISCLAIMER

The information, specifications, procedures, methods and recommendations herein (together "information") are presented by Vincotech to reader in good faith, are believed to be accurate and reliable, but may well be incomplete and/or not applicable to all conditions or situations that may exist or occur. Vincotech reserves the right to make any changes without further notice to any products to improve reliability, function or design. No representation, guarantee or warranty is made to reader as to the accuracy, reliability or completeness of said information or that the application or use of any of the same will avoid hazards, accidents, losses, damages or injury of any kind to persons or property or that the same will not infringe third parties rights or give desired results. It is reader's sole responsibility to test and determine the suitability of the information and the product for reader's intended use.

LIFE SUPPORT POLICY

Vincotech products are not authorised for use as critical components in life support devices or systems without the express written approval of Vincotech.

As used herein:

1. Life support devices or systems are devices or systems which, (a) are intended for surgical implant into the body, or (b) support or sustain life, or (c) whose failure to perform when properly used in accordance with instructions for use provided in labelling can be reasonably expected to result in significant injury to the user.
2. A critical component is any component of a life support device or system whose failure to perform can be reasonably expected to cause the failure of the life support device or system, or to affect its safety or effectiveness.