

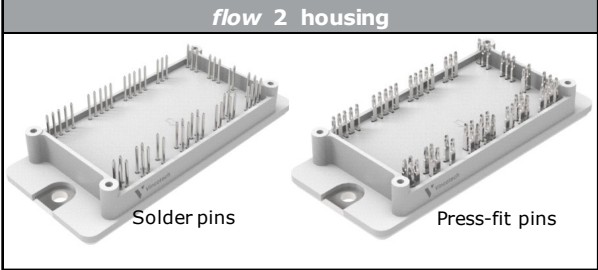
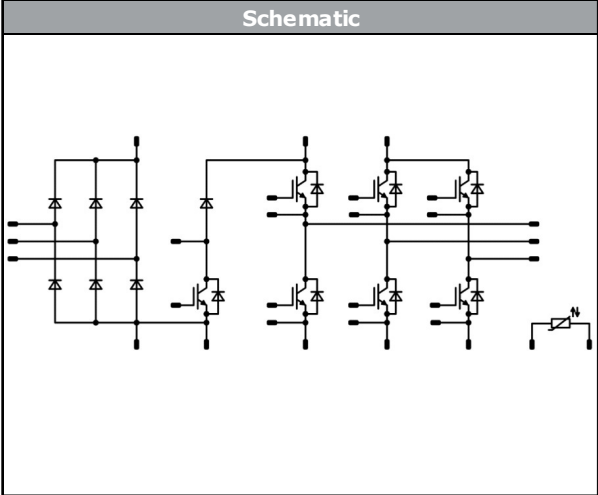

<i>flow PIM 2</i>	<b>1200 V / 75 A</b>
<div style="border: 1px solid black; padding: 5px; margin-bottom: 5px;"> <p style="text-align: center; background-color: #ccc; margin: 0;"><b>Features</b></p> <ul style="list-style-type: none"> <li>IGBT M7 with low <math>V_{CEsat}</math> and improved EMC behavior</li> <li>Open emitter configuration</li> <li>Compact and low inductive design</li> <li>Built-in NTC</li> </ul> </div> <div style="border: 1px solid black; padding: 5px; margin-bottom: 5px;"> <p style="text-align: center; background-color: #ccc; margin: 0;"><b>Target applications</b></p> <ul style="list-style-type: none"> <li>Industrial Drives</li> </ul> </div> <div style="border: 1px solid black; padding: 5px;"> <p style="text-align: center; background-color: #ccc; margin: 0;"><b>Types</b></p> <ul style="list-style-type: none"> <li>30-F212PMA075M7-L889A79</li> <li>30-P212PMA075M7-L889A79Y</li> </ul> </div>	<div style="border: 1px solid black; padding: 5px; margin-bottom: 5px;"> <p style="text-align: center; background-color: #ccc; margin: 0;"><i>flow 2 housing</i></p>  <p style="text-align: center; margin: 0;">Solder pins      Press-fit pins</p> </div> <div style="border: 1px solid black; padding: 5px;"> <p style="text-align: center; background-color: #ccc; margin: 0;"><b>Schematic</b></p>  </div>

## Maximum Ratings

$T_j = 25\text{ °C}$ , unless otherwise specified

Parameter	Symbol	Condition	Value	Unit
<b>Rectifier Diode</b>				
Peak Repetitive Reverse Voltage	$V_{RRM}$		1600	V
Continuous (direct) forward current	$I_F$		75	A
Surge (non-repetitive) forward current	$I_{FSM}$	$t_p = 10\text{ ms, sin } 180^\circ$ $T_j = 150\text{ °C}$	890	A
Surge current capability	$I^2t$		3960	A <sup>2</sup> s
Total power dissipation	$P_{tot}$	$T_j = T_{jmax}$ $T_s = 80\text{ °C}$	156	W
Maximum Junction Temperature	$T_{jmax}$		150	°C



Vincotech

## Maximum Ratings

$T_j = 25\text{ °C}$ , unless otherwise specified

Parameter	Symbol	Condition	Value	Unit
<b>Inverter Switch</b>				
Collector-emitter voltage	$V_{CES}$		1200	V
Collector current	$I_C$		75	A
Repetitive peak collector current	$I_{CRM}$	$t_p$ limited by $T_{jmax}$	150	A
Total power dissipation	$P_{tot}$	$T_j = T_{jmax}$ $T_s = 80\text{ °C}$	190	W
Gate-emitter voltage	$V_{GES}$		$\pm 20$	V
Maximum junction temperature	$T_{jmax}$		175	°C

<b>Inverter Diode</b>				
Peak repetitive reverse voltage	$V_{RRM}$		1200	V
Continuous (direct) forward current	$I_F$	$T_j = T_{jmax}$ $T_s = 80\text{ °C}$	80	A
Repetitive peak forward current	$I_{FRM}$	$T_j$ limited by $T_{jmax}$	200	A
Total power dissipation	$P_{tot}$	$T_j = T_{jmax}$ $T_s = 80\text{ °C}$	142	W
Maximum junction temperature	$T_{jmax}$		175	°C

<b>Brake Switch</b>				
Collector-emitter voltage	$V_{CES}$		1200	V
Collector current	$I_C$		50	A
Repetitive peak collector current	$I_{CRM}$	$t_p$ limited by $T_{jmax}$	100	A
Total power dissipation	$P_{tot}$	$T_j = T_{jmax}$ $T_s = 80\text{ °C}$	162	W
Gate-emitter voltage	$V_{GES}$		$\pm 20$	V
Maximum junction temperature	$T_{jmax}$		175	°C

<b>Brake Diode</b>				
Peak repetitive reverse voltage	$V_{RRM}$		1200	V
Continuous (direct) forward current	$I_F$		25	A
Repetitive peak forward current	$I_{FRM}$	$T_j$ limited by $T_{jmax}$	50	A
Total power dissipation	$P_{tot}$	$T_j = T_{jmax}$ $T_s = 80\text{ °C}$	70	W
Maximum junction temperature	$T_{jmax}$		175	°C



## Maximum Ratings

$T_j = 25\text{ °C}$ , unless otherwise specified

Parameter	Symbol	Condition	Value	Unit
<b>Brake Sw. Protection Diode</b>				
Peak repetitive reverse voltage	$V_{RRM}$		1200	V
Continuous (direct) forward current	$I_F$		5	A
Repetitive peak forward current	$I_{FRM}$		10	A
Total power dissipation	$P_{tot}$	$T_j = T_{jmax}$ $T_s = 80\text{ °C}$	34	W
Maximum junction temperature	$T_{jmax}$		175	°C

## Module Properties

### Thermal Properties

Storage temperature	$T_{stg}$		-40...+125	°C
Operation temperature under switching condition	$T_{top}$		-40...( $T_{jmax} - 25$ )	°C

### Isolation Properties

Isolation voltage	$V_{isol}$	DC Test Voltage* $t_p = 2\text{ s}$	6000	V
		AC Voltage $t_p = 1\text{ min}$	2500	V
Creepage distance			min. 12,7	mm
Clearance		Solder Pins	11,82	mm
		Press-fit Pins	11,58	mm
Comparative Tracking Index	CTI		> 200	

\*100 % tested in production



Vincotech

**30-F212PMA075M7-L889A79**  
**30-P212PMA075M7-L889A79Y**  
datasheet

## Characteristic Values

Parameter	Symbol	Conditions					Value			Unit
		$V_{GE}$ [V] $V_{GS}$ [V]	$V_{CE}$ [V] $V_{DS}$ [V] $V_F$ [V]	$I_C$ [A] $I_D$ [A] $I_F$ [A]	$T_j$ [°C]	Min	Typ	Max		

### Rectifier Diode

#### Static

Forward voltage	$V_F$			75	25 125 150		1,10 1,04 1,05	1,8	V
Reverse leakage current	$I_r$		1600		25 145			50 1100	$\mu$ A

#### Thermal

Thermal resistance junction to sink	$R_{th(j-s)}$	$\lambda_{paste} = 3,4$ W/mK (PSX)					0,45		K/W
-------------------------------------	---------------	---------------------------------------	--	--	--	--	------	--	-----



## Characteristic Values

Parameter	Symbol	Conditions					Value			Unit
		$V_{GS}$ [V]	$V_{GE}$ [V]	$V_{DS}$ [V]	$I_D$ [A]	$T_j$ [°C]	Min	Typ	Max	

### Inverter Switch

#### Static

Parameter	Symbol	$V_{GE} = V_{CE}$	$V_{GS}$ [V]	$V_{GE}$ [V]	$I_D$ [A]	$T_j$ [°C]	Min	Typ	Max	Unit
Gate-emitter threshold voltage	$V_{GE(th)}$				0,0075	25	5,4	6	6,6	V
Collector-emitter saturation voltage	$V_{CEsat}$		15		75	25 125 150		1,55 1,70 1,75	1,90	V
Collector-emitter cut-off current	$I_{CES}$		0	1200		25			100	μA
Gate-emitter leakage current	$I_{GES}$		20	0		25			500	nA
Internal gate resistance	$r_g$							4		Ω
Input capacitance	$C_{ies}$							16000		pF
Output capacitance	$C_{oes}$		0	10		25		480		
Reverse transfer capacitance	$C_{res}$							190		
Gate charge	$Q_g$		15	600	75	25		570		nC

#### Thermal

Parameter	Symbol	$\lambda_{paste} = 3,4$ W/mK (PSX)	$V_{GS}$ [V]	$V_{GE}$ [V]	$I_D$ [A]	$T_j$ [°C]	Min	Typ	Max	Unit
Thermal resistance junction to sink	$R_{th(j-s)}$							0,50		K/W

#### Dynamic

Parameter	Symbol	$R_{goff} = 4$ Ω $R_{gon} = 4$ Ω	$V_{GS}$ [V]	$V_{GE}$ [V]	$I_D$ [A]	$T_j$ [°C]	Min	Typ	Max	Unit
Turn-on delay time	$t_{d(on)}$					25 125 150		259 267 269		ns
Rise time	$t_r$					25 125 150		40 50 51		
Turn-off delay time	$t_{d(off)}$					25 125 150		227 259 266		
Fall time	$t_f$					25 125 150		87 106 111		
Turn-on energy (per pulse)	$E_{on}$	$Q_{t-FWD} = 8$ μC $Q_{t-FWD} = 12,6$ μC $Q_{t-FWD} = 14,2$ μC				25 125 150		6,83 9,29 9,94		mWs
Turn-off energy (per pulse)	$E_{off}$					25 125 150		5,17 6,89 7,30		



## Characteristic Values

Parameter	Symbol	Conditions					Value			Unit
		$V_{GE}$ [V] $V_{GS}$ [V]	$V_{CE}$ [V] $V_{DS}$ [V]	$I_C$ [A] $I_D$ [A]	$I_D$ [A] $I_F$ [A]	$T_j$ [°C]	Min	Typ	Max	

### Inverter Diode

#### Static

Forward voltage	$V_F$				100	25 125 150		1,82 1,96 1,97	2,1	V
Reverse leakage current	$I_R$			1200		25			60	μA

#### Thermal

Thermal resistance junction to sink	$R_{th(j-s)}$	$\lambda_{paste} = 3,4$ W/mK (PSX)						0,67		K/W
-------------------------------------	---------------	---------------------------------------	--	--	--	--	--	------	--	-----

#### Dynamic

Peak recovery current	$I_{RRM}$					25 125 150		63 64 66		A
Reverse recovery time	$t_{rr}$					25 125 150		297 458 502		ns
Recovered charge	$Q_r$	$di/dt = 1913$ A/μs $di/dt = 1557$ A/μs $di/dt = 1447$ A/μs	±15	600	75	25 125 150		8,02 12,63 14,17		μC
Reverse recovered energy	$E_{rec}$					25 125 150		2,75 4,59 5,24		mWs
Peak rate of fall of recovery current	$(di_{rr}/dt)_{max}$					25 125 150		592 340 314		A/μs



## Characteristic Values

Parameter	Symbol	Conditions					Value			Unit
		$V_{GE}$ [V] $V_{GS}$ [V]	$V_{CE}$ [V] $V_{DS}$ [V] $V_F$ [V]	$I_C$ [A] $I_D$ [A] $I_F$ [A]	$T_j$ [°C]	Min	Typ	Max		

### Brake Switch

#### Static

Gate-emitter threshold voltage	$V_{GE(th)}$	$V_{GE} = V_{CE}$			0,005	25	5,4	6	6,6	V
Collector-emitter saturation voltage	$V_{CEsat}$		15		50	25 125 150		1,55 1,77 1,83	1,9	V
Collector-emitter cut-off current	$I_{CES}$		0	1200		25			90	μA
Gate-emitter leakage current	$I_{GES}$		15	0		25			500	nA
Internal gate resistance	$r_g$							none		Ω
Input capacitance	$C_{ies}$							10000		pF
Output capacitance	$C_{oes}$		0	10		25		350		
Reverse transfer capacitance	$C_{res}$							130		
Gate charge	$Q_g$		15	600	50	25		410		nC

#### Thermal

Thermal resistance junction to sink	$R_{th(j-s)}$	$\lambda_{paste} = 3,4$ W/mK (PSX)						0,59		K/W
-------------------------------------	---------------	---------------------------------------	--	--	--	--	--	------	--	-----

#### Dynamic

Turn-on delay time	$t_{d(on)}$					25 125 150		116 105 105		ns
Rise time	$t_r$	$R_{goff} = 8 \Omega$ $R_{gon} = 8 \Omega$				25 125 150		58 64 66		
Turn-off delay time	$t_{d(off)}$		15/0	700	50	25 125 150		330 369 374		
Fall time	$t_f$					25 125 150		85 117 124		
Turn-on energy (per pulse)	$E_{on}$	$Q_{fFWD} = 3,8 \mu C$ $Q_{fFWD} = 5,6 \mu C$ $Q_{fFWD} = 6,2 \mu C$				25 125 150		4,49 5,50 5,80		
Turn-off energy (per pulse)	$E_{off}$					25 125 150		4,94 5,48 5,76		



## Characteristic Values

Parameter	Symbol	Conditions					Value			Unit
		$V_{GE}$ [V]	$V_{CE}$ [V]	$I_C$ [A]	$T_j$ [°C]	Min	Typ	Max		

### Brake Diode

#### Static

Parameter	Symbol	$V_{GE}$ [V]	$V_{CE}$ [V]	$I_C$ [A]	$T_j$ [°C]	Min	Typ	Max	Unit
Forward voltage	$V_F$			25	25 125 150		1,63 1,70 1,69	2,1	V
Reverse leakage current	$I_R$			1200	25			35	μA

#### Thermal

Parameter	Symbol	Conditions	Value	Unit
Thermal resistance junction to sink	$R_{th(j-s)}$	$\lambda_{paste} = 3,4$ W/mK (PSX)	1,36	K/W

#### Dynamic

Parameter	Symbol	$V_{GE}$ [V]	$V_{CE}$ [V]	$I_C$ [A]	$T_j$ [°C]	Min	Typ	Max	Unit
Peak recovery current	$I_{RRM}$				25 125 150		30 32 33		A
Reverse recovery time	$t_{rr}$				25 125 150		263 376 411		ns
Recovered charge	$Q_r$		15/0	700	50		3,82 5,59 6,19		μC
Reverse recovered energy	$E_{rec}$				25 125 150		1,70 2,62 2,95		mWs
Peak rate of fall of recovery current	$(di_{rr}/dt)_{max}$				25 125 150		272 192 183		A/μs

### Brake Sw. Protection Diode

#### Static

Parameter	Symbol	$V_{GE}$ [V]	$V_{CE}$ [V]	$I_C$ [A]	$T_j$ [°C]	Min	Typ	Max	Unit
Forward voltage	$V_F$			5	25 125 150		1,57 1,65 1,65	2,1	V
Reverse leakage current	$I_R$			1200	25			20	μA

#### Thermal

Parameter	Symbol	Conditions	Value	Unit
Thermal resistance junction to sink	$R_{th(j-s)}$	$\lambda_{paste} = 3,4$ W/mK (PSX)	2,76	K/W





### Characteristic Values

Parameter	Symbol	Conditions				Value			Unit
		$V_{GE}$ [V] $V_{GS}$ [V]	$V_{CE}$ [V] $V_{DS}$ [V]	$I_C$ [A] $I_D$ [A]	$T_j$ [°C]	Min	Typ	Max	

#### Thermistor

Rated resistance	$R$				25		22		kΩ
Deviation of $R_{100}$	$\Delta_{R/R}$	$R_{100} = 1484 \Omega$			100	-5		5	%
Power dissipation	$P$				25		5		mW
Power dissipation constant					25		1,5		mW/K
B-value	$B_{(25/50)}$	Tol. $\pm 1 \%$			25		3962		K
B-value	$B_{(25/100)}$	Tol. $\pm 1 \%$			25		4000		K
Vincotech NTC Reference								I	



## Rectifier Diode Characteristics

**figure 1. Rectifier Diode**  
**Typical forward characteristics**

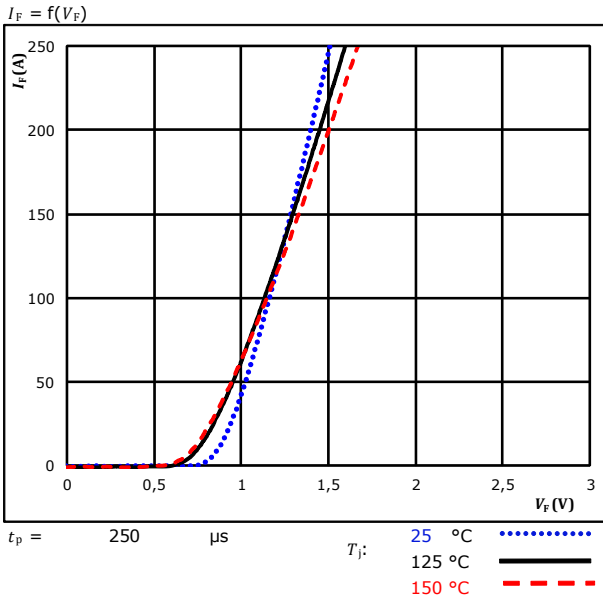

**figure 2. Rectifier Diode**  
**Transient thermal impedance as a function of pulse width**

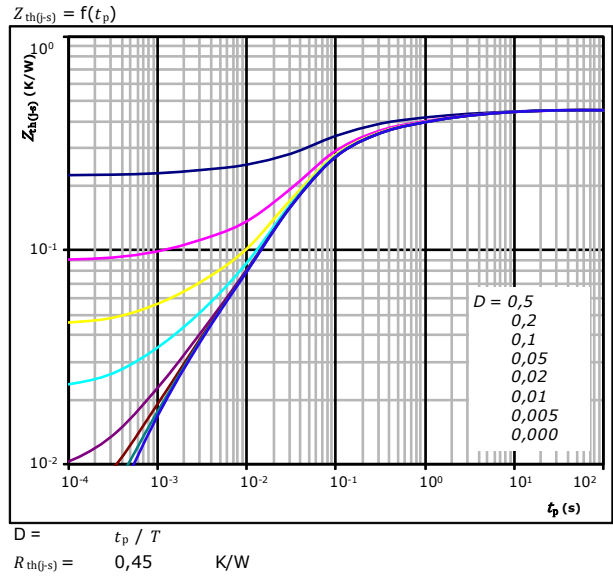

Diode thermal model values

$R$ (K/W)	$\tau$ (s)
3,06E-02	7,38E+00
5,87E-02	1,30E+00
1,21E-01	1,90E-01
2,00E-01	4,49E-02
2,12E-02	9,83E-03
1,85E-02	1,38E-03



## Inverter Switch Characteristics

**figure 1.** IGBT

Typical output characteristics

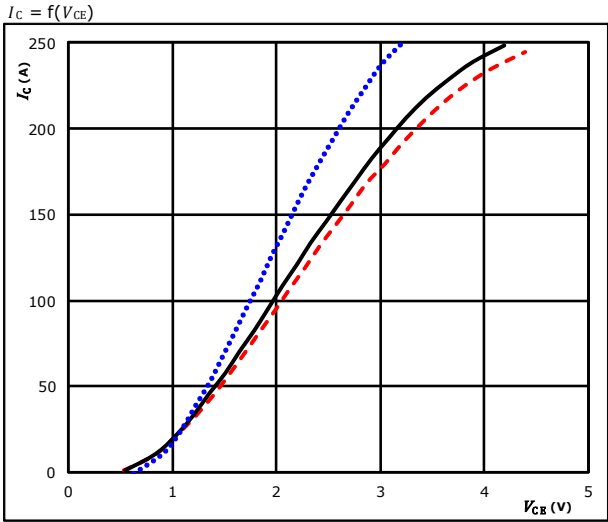

$t_p = 250 \mu s$   $T_j: 25 \text{ }^\circ C$  .....  
 $V_{GE} = 15 V$   $T_j: 125 \text{ }^\circ C$  ———  
 $T_j: 150 \text{ }^\circ C$  - - - - -

**figure 2.** IGBT

Typical output characteristics

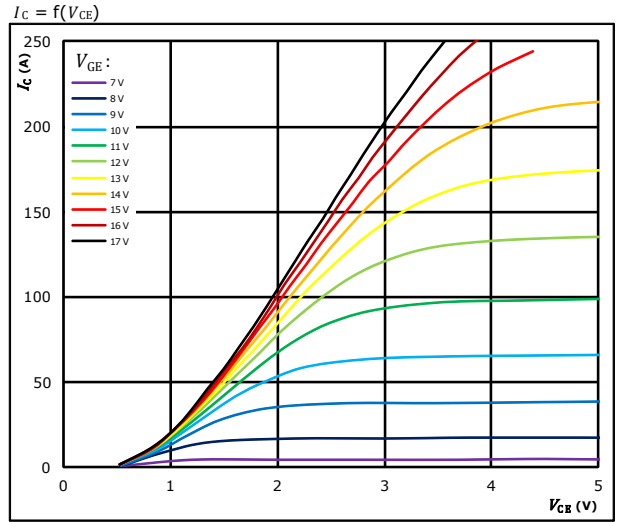

$t_p = 250 \mu s$   
 $T_j = 150 \text{ }^\circ C$   
 $V_{GE}$  from 7 V to 17 V in steps of 1 V

**figure 3.** IGBT

Typical transfer characteristics

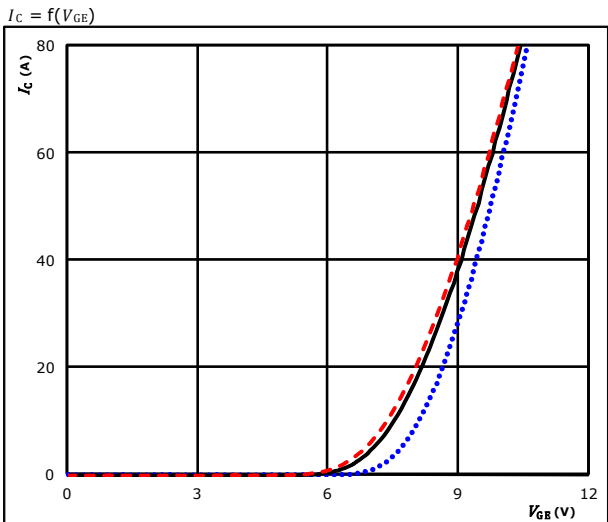

$t_p = 100 \mu s$   $T_j: 25 \text{ }^\circ C$  .....  
 $V_{CE} = 10 V$   $T_j: 125 \text{ }^\circ C$  ———  
 $T_j: 150 \text{ }^\circ C$  - - - - -

**figure 4.** IGBT

Transient thermal impedance as function of pulse duration

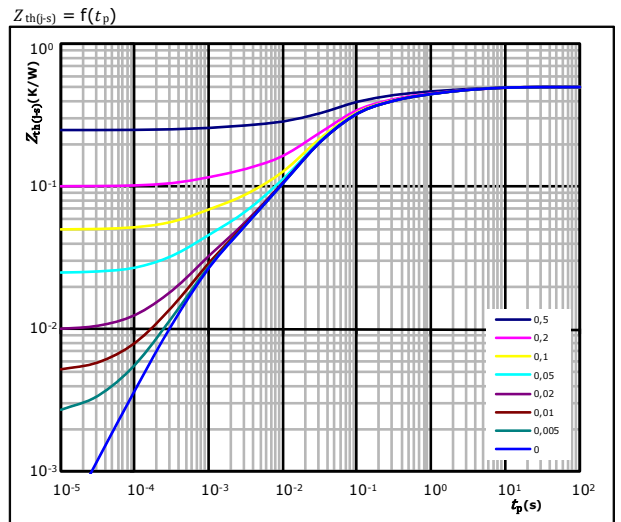

$D = t_p / T$   
 $R_{th(j-s)} = 0,50 \text{ K/W}$

IGBT thermal model values

R (K/W)	$\tau$ (s)
3,92E-02	4,73E+00
6,01E-02	9,48E-01
1,18E-01	1,70E-01
2,25E-01	3,80E-02
3,32E-02	9,18E-03
2,48E-02	8,63E-04



### Inverter Switch Characteristics

**figure 5. IGBT**

Safe operating area

$$I_C = f(V_{CE})$$

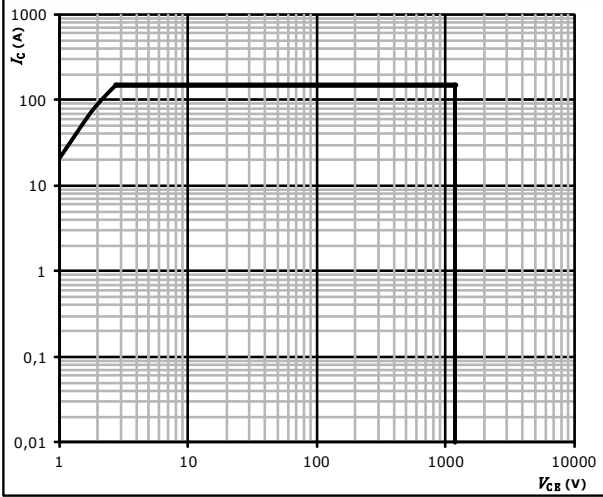

- $D =$  single pulse
- $T_s =$  80 °C
- $V_{GE} =$  ±15 V
- $T_j =$   $T_{jmax}$



### Inverter Diode Characteristics

**figure 1.** FWD

Typical forward characteristics

$$I_F = f(V_F)$$

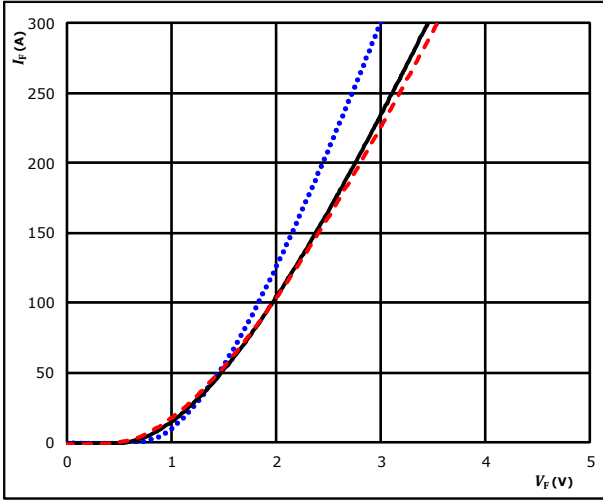

$t_p = 250 \mu s$   
 $T_j$ : 25 °C .....  
 125 °C ———  
 150 °C - - - -

**figure 2.** FWD

Transient thermal impedance as a function of pulse width

$$Z_{th(j-s)} = f(t_p)$$

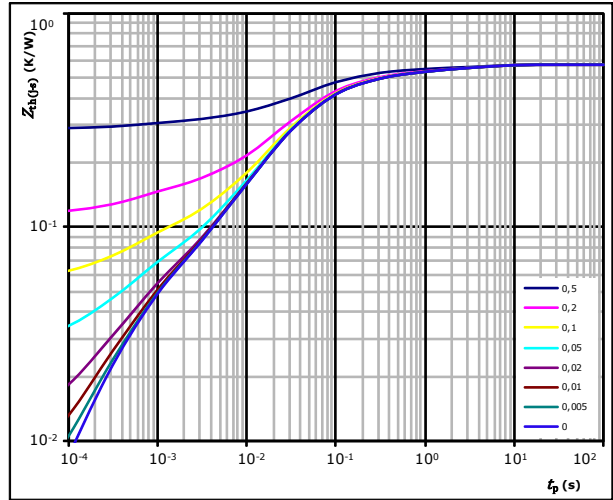

$D = t_p / T$   
 $R_{th(j-s)} = 0,58 \text{ K/W}$

FWD thermal model values

$R$ (K/W)	$\tau$ (s)
4,89E-02	3,41E+00
7,07E-02	4,06E-01
2,02E-01	7,46E-02
1,90E-01	2,27E-02
3,24E-02	3,47E-03
3,35E-02	4,78E-04



## Brake Switch Characteristics

**figure 1.** IGBT

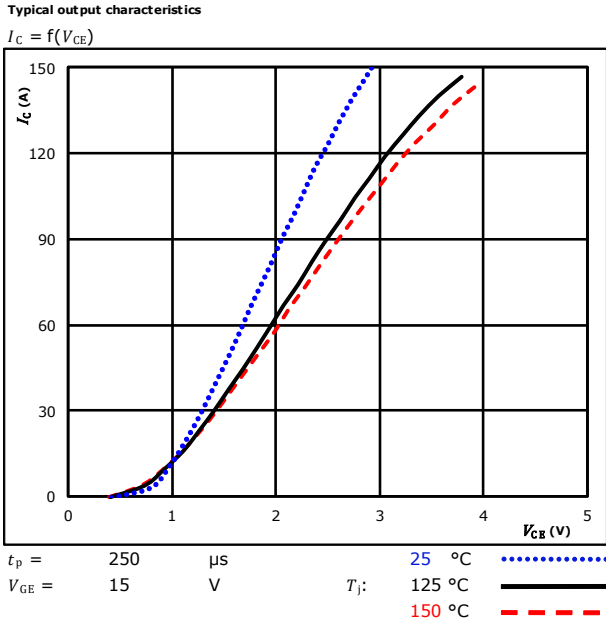

**figure 2.** IGBT

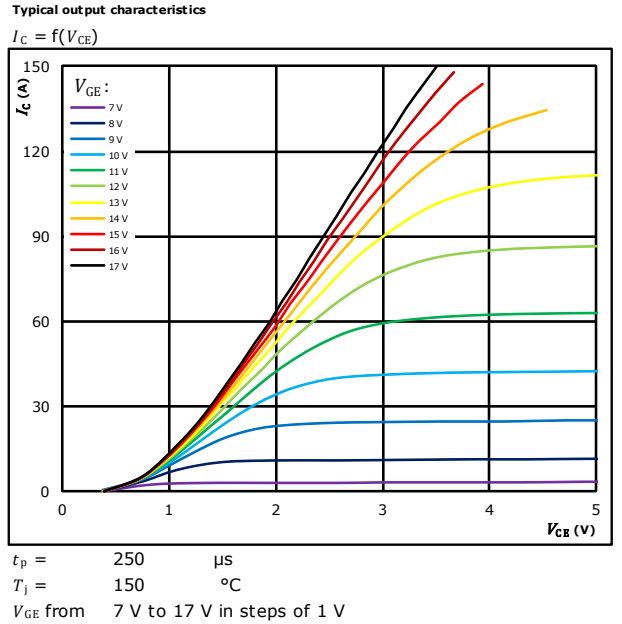

**figure 3.** IGBT

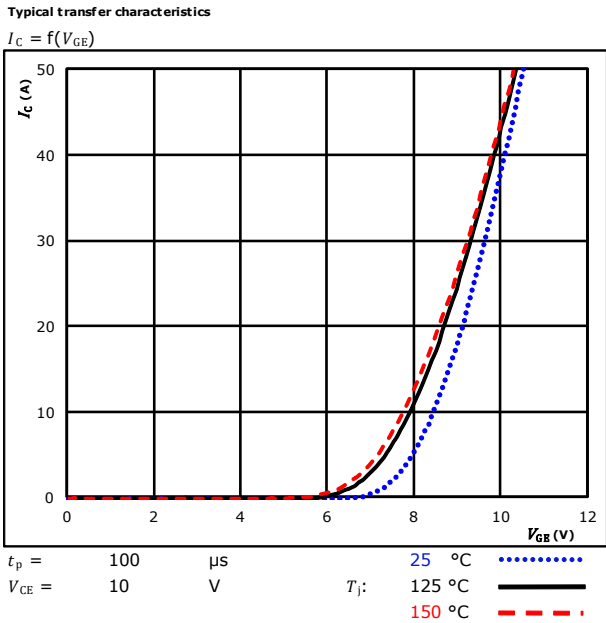

**figure 4.** IGBT

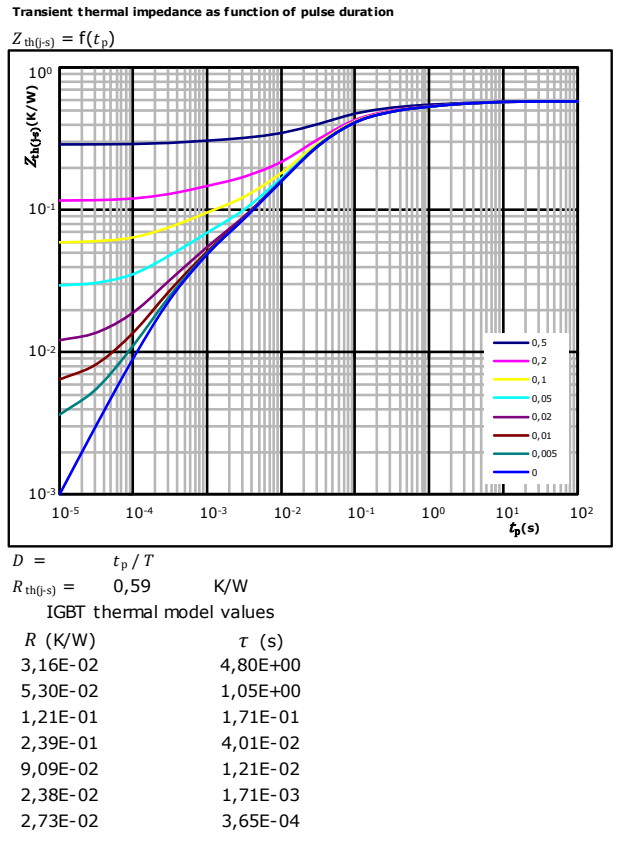



### Brake Switch Characteristics

**figure 5.** IGBT

Safe operating area

$I_C = f(V_{CE})$

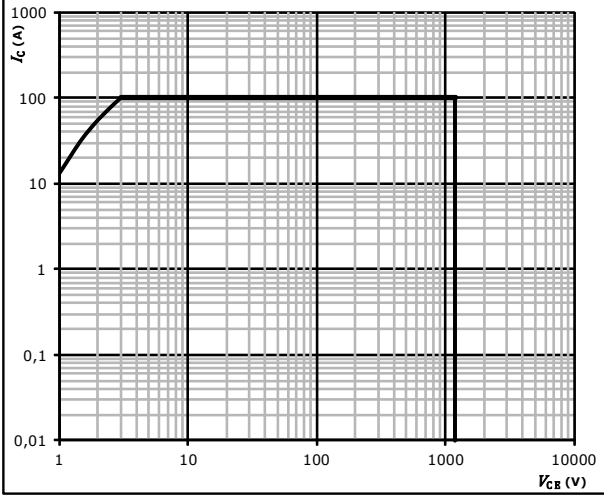

- $D =$  single pulse
- $T_s =$  80 °C
- $V_{GE} =$  ±15 V
- $T_j = T_{jmax}$



## Brake Diode Characteristics

**figure 1.** FWD

Typical forward characteristics

$$I_F = f(V_F)$$

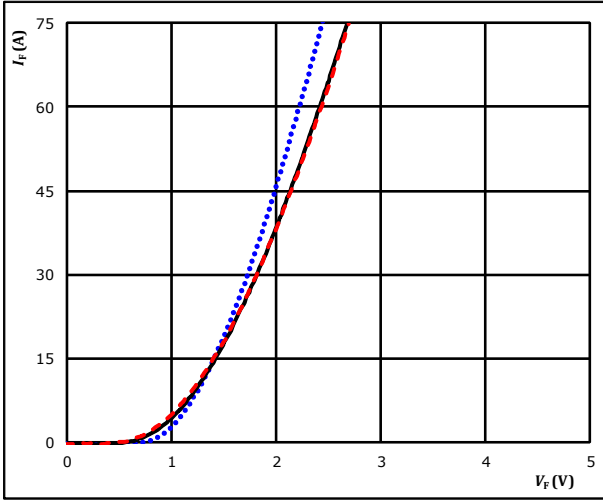

$t_p = 250 \mu s$

$T_j$ : 25 °C .....  
 125 °C ———  
 150 °C - - - -

**figure 2.** FWD

Transient thermal impedance as a function of pulse width

$$Z_{th(j-s)} = f(t_p)$$

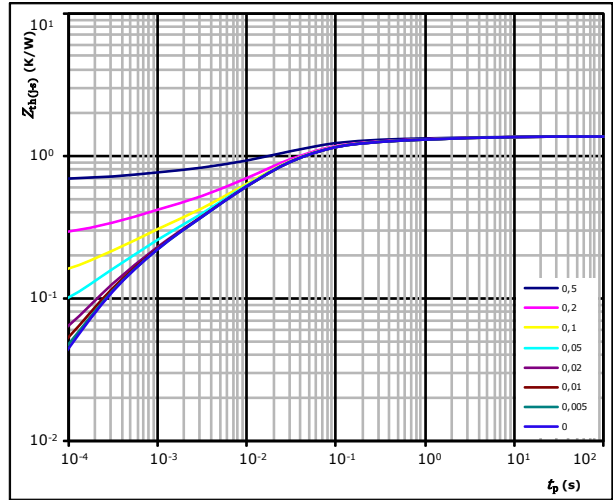

$D = t_p / T$

$R_{th(j-s)} = 1,36 \text{ K/W}$

FWD thermal model values

$R$ (K/W)	$\tau$ (s)
4,30E-02	6,93E+00
7,33E-02	1,01E+00
1,84E-01	1,33E-01
5,52E-01	2,95E-02
2,85E-01	7,43E-03
1,16E-01	1,34E-03
1,06E-01	3,07E-04





## Brake Sw. Protection Diode Characteristics

**figure 1.** Prot. Diode

Typical forward characteristics

$$I_F = f(V_F)$$

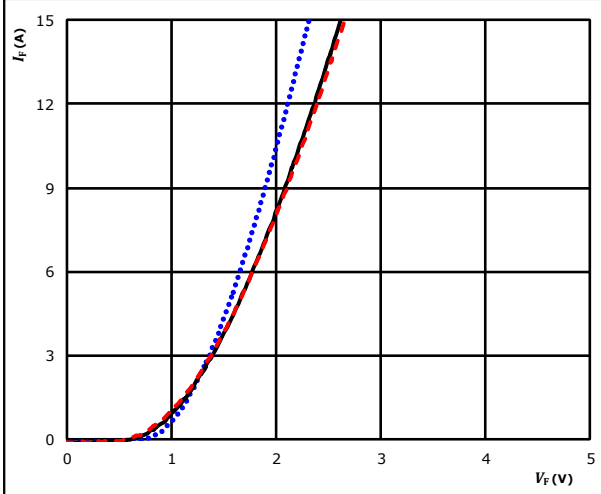

$t_p = 250 \mu s$   
 $T_j$ : 25 °C .....  
 125 °C ———  
 150 °C - - - -

**figure 2.** Prot. Diode

Transient thermal impedance as a function of pulse width

$$Z_{th(j-s)} = f(t_p)$$

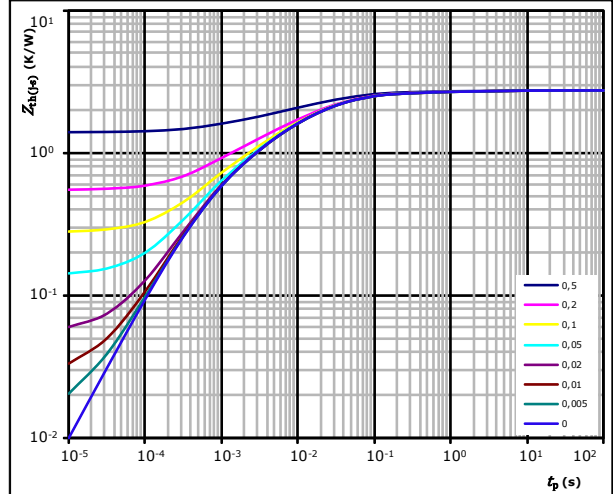

$D = t_p / T$   
 $R_{th(j-s)} = 2,76 \text{ K/W}$   
 Prot. Diode thermal model values

$R$ (K/W)	$\tau$ (s)
6,58E-02	4,81E+00
1,43E-01	3,47E-01
6,08E-01	4,61E-02
8,65E-01	1,40E-02
7,08E-01	2,91E-03
3,69E-01	5,42E-04

## Thermistor Characteristics

**figure 1.** Thermistor

Typical NTC characteristic as a function of temperature

$$R = f(T)$$

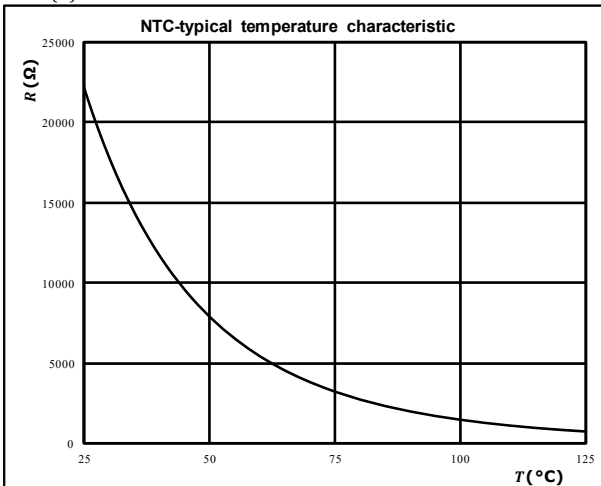



## Inverter Switching Characteristics

**figure 1.** IGBT

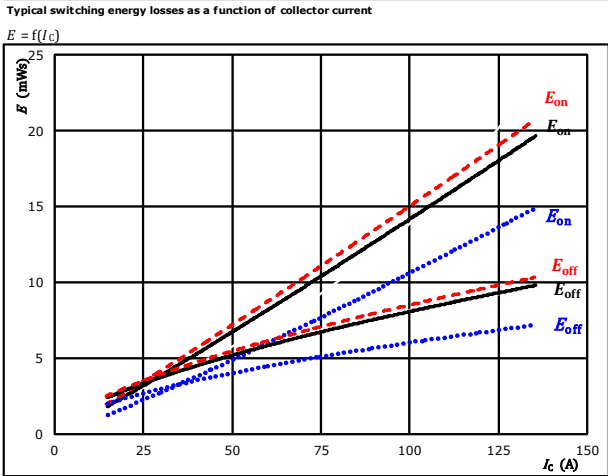

With an inductive load at

$V_{CE} = 600$ V	$T_j: 25$ °C	.....
$V_{GE} = \pm 15$ V	$125$ °C	————
$R_{gon} = 4$ Ω	$150$ °C	-----
$R_{goff} = 4$ Ω		

**figure 2.** IGBT

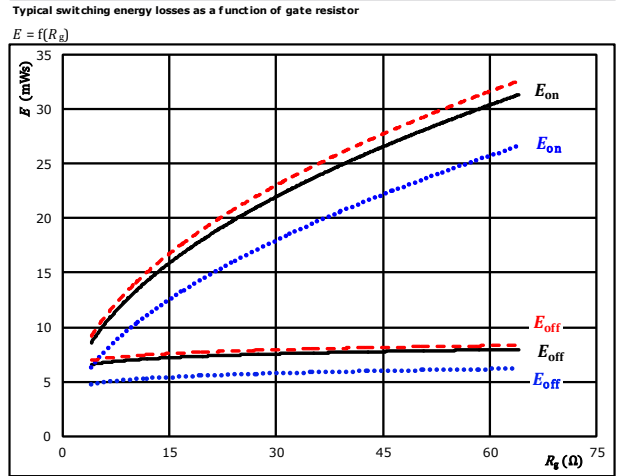

With an inductive load at

$V_{CE} = 600$ V	$T_j: 25$ °C	.....
$V_{GE} = \pm 15$ V	$125$ °C	————
$I_C = 75$ A	$150$ °C	-----

**figure 3.** FWD

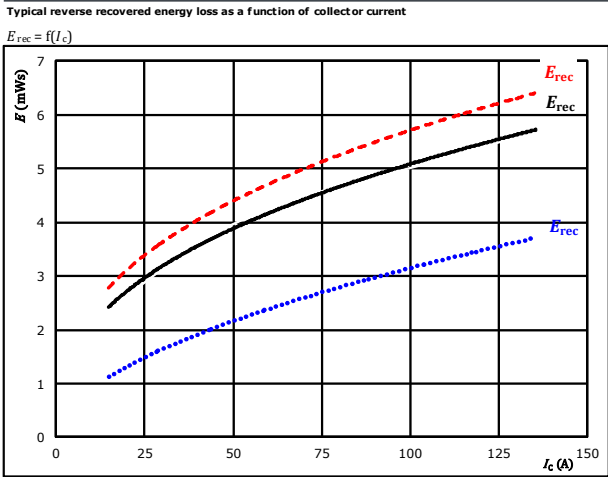

With an inductive load at

$V_{CE} = 600$ V	$T_j: 25$ °C	.....
$V_{GE} = \pm 15$ V	$125$ °C	————
$R_{gon} = 4$ Ω	$150$ °C	-----

**figure 4.** FWD

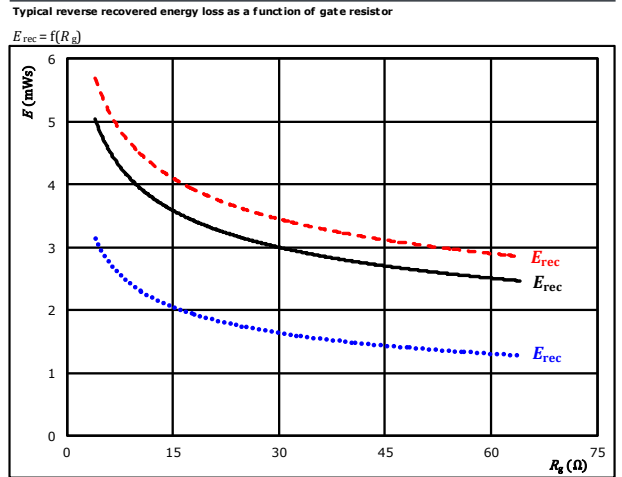

With an inductive load at

$V_{CE} = 600$ V	$T_j: 25$ °C	.....
$V_{GE} = \pm 15$ V	$125$ °C	————
$I_C = 75$ A	$150$ °C	-----



## Inverter Switching Characteristics

**figure 5. IGBT**

Typical switching times as a function of collector current

$$t = f(I_c)$$

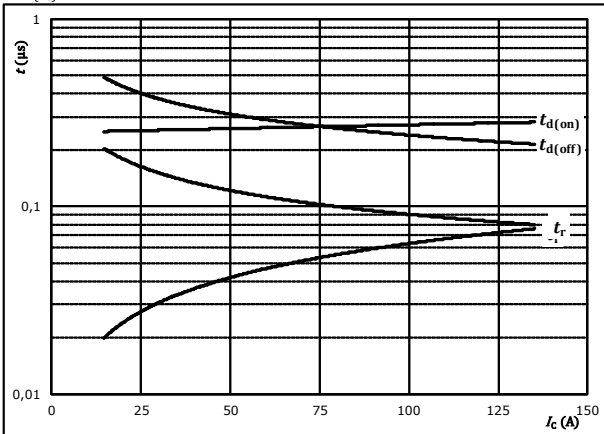

With an inductive load at

$T_j =$	150	°C
$V_{CE} =$	600	V
$V_{GE} =$	±15	V
$R_{gon} =$	4	Ω
$R_{goff} =$	4	Ω

**figure 6. IGBT**

Typical switching times as a function of gate resistor

$$t = f(R_g)$$

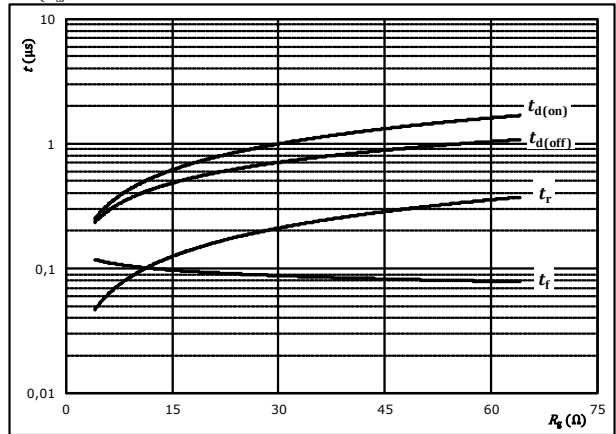

With an inductive load at

$T_j =$	150	°C
$V_{CE} =$	600	V
$V_{GE} =$	±15	V
$I_c =$	75	A

**figure 7. FWD**

Typical reverse recovery time as a function of collector current

$$t_{rr} = f(I_c)$$

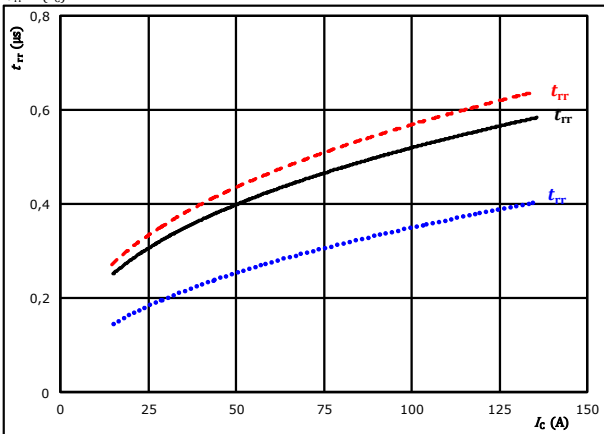

At

$V_{CE} =$	600	V	$T_j =$	25 °C	.....
$V_{GE} =$	±15	V		125 °C	————
$R_{gon} =$	4	Ω		150 °C	-----

**figure 8. FWD**

Typical reverse recovery time as a function of IGBT turn on gate resistor

$$t_{rr} = f(R_{gon})$$

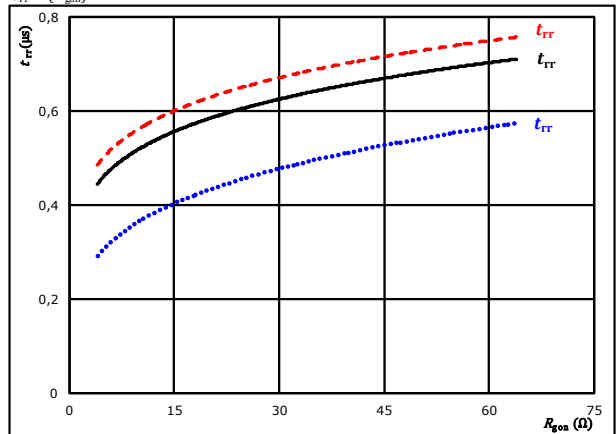

At

$V_{CE} =$	600	V	$T_j =$	25 °C	.....
$V_{GE} =$	±15	V		125 °C	————
$I_c =$	75	A		150 °C	-----



## Inverter Switching Characteristics

**figure 9.** FWD

Typical recovered charge as a function of collector current

$$Q_r = f(I_c)$$

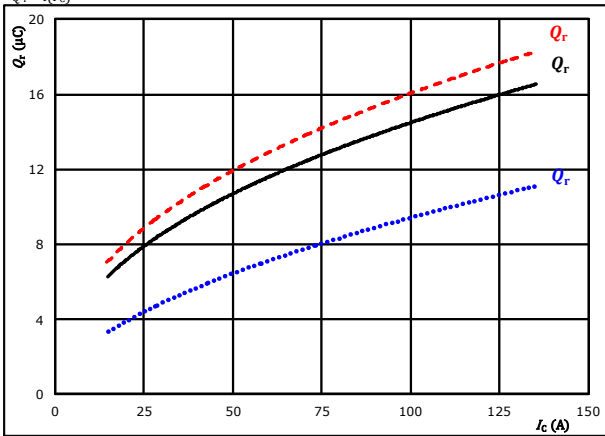

At  $V_{CE} = 600$  V  $T_j = 25$  °C (dotted blue)  
 $V_{GE} = \pm 15$  V  $T_j = 125$  °C (solid black)  
 $R_{gpn} = 4$  Ω  $T_j = 150$  °C (dashed red)

**figure 10.** FWD

Typical recovered charge as a function of IGBT turn on gate resistor

$$Q_r = f(R_{gpn})$$

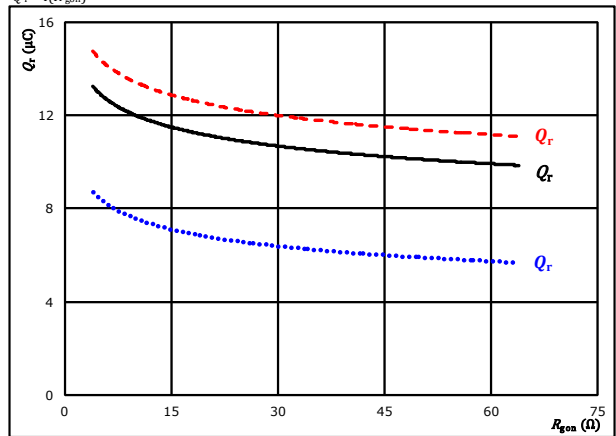

At  $V_{CE} = 600$  V  $T_j = 25$  °C (dotted blue)  
 $V_{GE} = \pm 15$  V  $T_j = 125$  °C (solid black)  
 $I_c = 75$  A  $T_j = 150$  °C (dashed red)

**figure 11.** FWD

Typical peak reverse recovery current current as a function of collector current

$$I_{RM} = f(I_c)$$

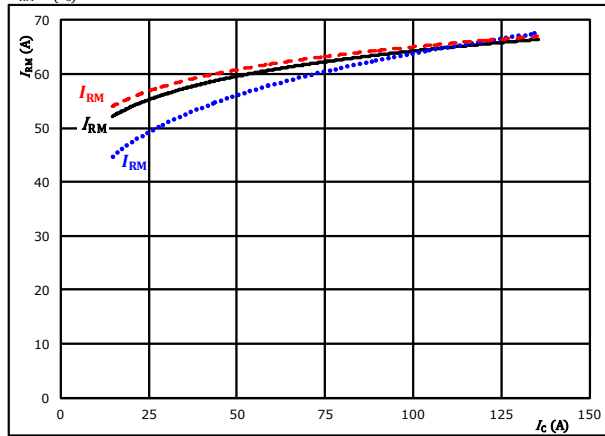

At  $V_{CE} = 600$  V  $T_j = 25$  °C (dotted blue)  
 $V_{GE} = \pm 15$  V  $T_j = 125$  °C (solid black)  
 $R_{gpn} = 4$  Ω  $T_j = 150$  °C (dashed red)

**figure 12.** FWD

Typical peak reverse recovery current current as a function of IGBT turn on gate resistor

$$I_{RM} = f(R_{gpn})$$

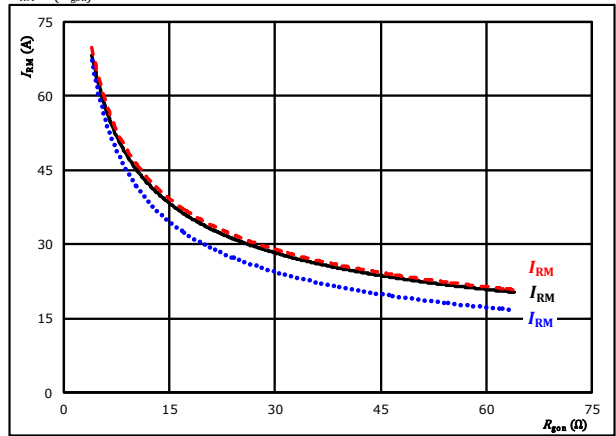

At  $V_{CE} = 600$  V  $T_j = 25$  °C (dotted blue)  
 $V_{GE} = \pm 15$  V  $T_j = 125$  °C (solid black)  
 $I_c = 75$  A  $T_j = 150$  °C (dashed red)



## Inverter Switching Characteristics

**figure 13.** FWD

Typical rate of fall of forward and reverse recovery current as a function of collector current  
 $di_f/dt, di_{rr}/dt = f(I_c)$

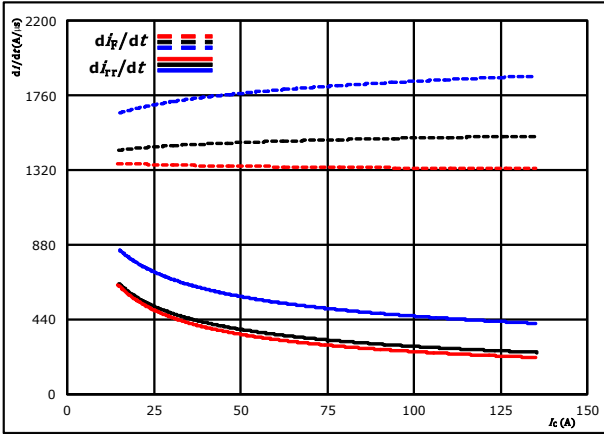

At  $V_{CE} = 600$  V  $T_j = 25$  °C (dotted blue)  
 $V_{GE} = \pm 15$  V  $T_j = 125$  °C (solid black)  
 $R_{g(on)} = 4$  Ω  $T_j = 150$  °C (dashed red)

**figure 14.** FWD

Typical rate of fall of forward and reverse recovery current as a function of IGBT turn on gate resistor  
 $di_f/dt, di_{rr}/dt = f(R_{g(on)})$

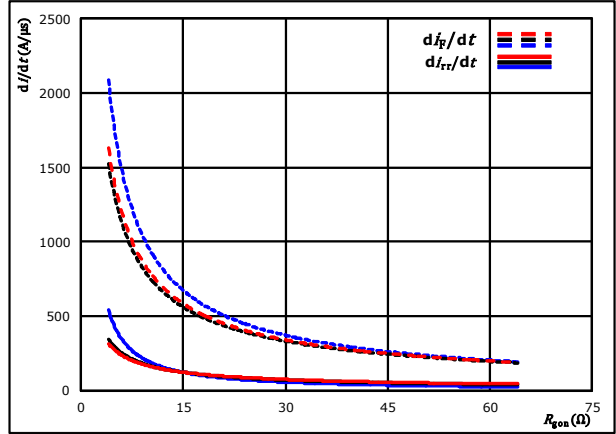

At  $V_{CE} = 600$  V  $T_j = 25$  °C (dotted blue)  
 $V_{GE} = \pm 15$  V  $T_j = 125$  °C (solid black)  
 $I_c = 75$  A  $T_j = 150$  °C (dashed red)

**figure 15.** IGBT

Reverse bias safe operating area  
 $I_c = f(V_{CE})$

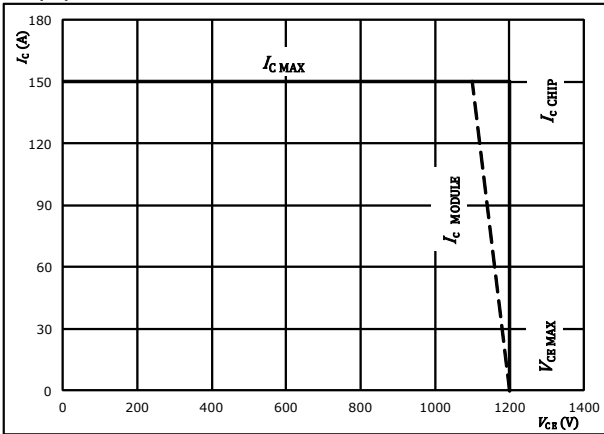

At  $T_j = 175$  °C  
 $R_{g(on)} = 4$  Ω  
 $R_{g(off)} = 4$  Ω



Vincotech

## Inverter Switching Definitions

**General conditions**

$T_j$	=	125 °C
$R_{gon}$	=	4 Ω
$R_{goff}$	=	4 Ω

**figure 1.** IGBT

Turn-off Switching Waveforms & definition of  $t_{doff}$ ,  $t_{Eoff}$  ( $t_{Eoff}$  = integrating time for  $E_{off}$ )

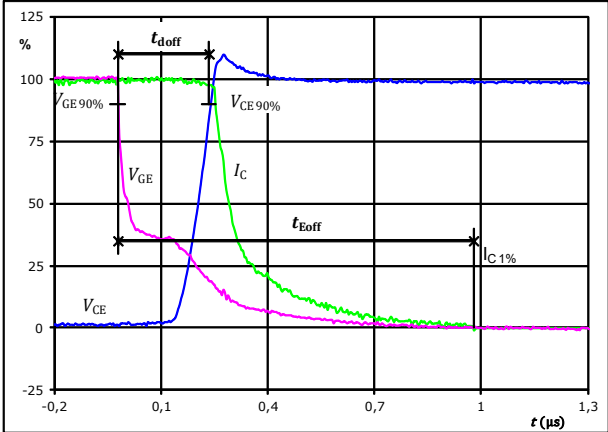

$V_{GE}(0\%) =$	-15	V
$V_{GE}(100\%) =$	15	V
$V_C(100\%) =$	600	V
$I_C(100\%) =$	75	A
$t_{doff} =$	0,259	μs
$t_{Eoff} =$	1,000	μs

**figure 2.** IGBT

Turn-on Switching Waveforms & definition of  $t_{don}$ ,  $t_{Eon}$  ( $t_{Eon}$  = integrating time for  $E_{on}$ )

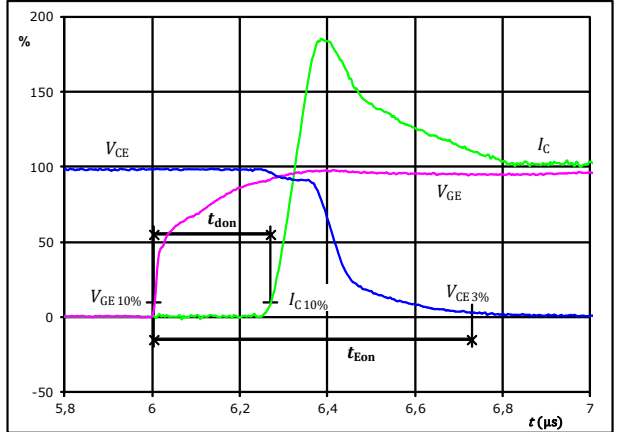

$V_{GE}(0\%) =$	-15	V
$V_{GE}(100\%) =$	15	V
$V_C(100\%) =$	600	V
$I_C(100\%) =$	75	A
$t_{don} =$	0,267	μs
$t_{Eon} =$	0,725	μs

**figure 3.** IGBT

Turn-off Switching Waveforms & definition of  $t_r$

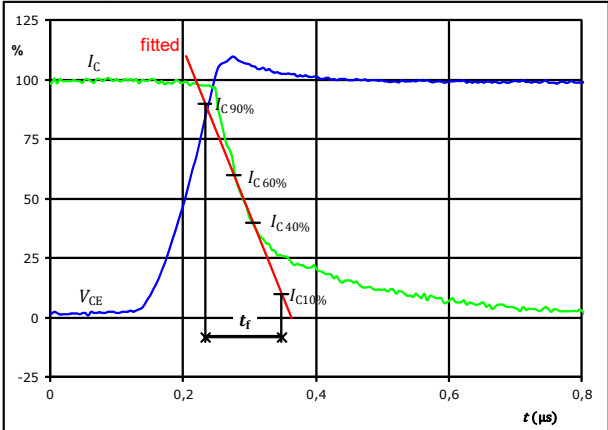

$V_C(100\%) =$	600	V
$I_C(100\%) =$	75	A
$t_r =$	0,106	μs

**figure 4.** IGBT

Turn-on Switching Waveforms & definition of  $t_r$

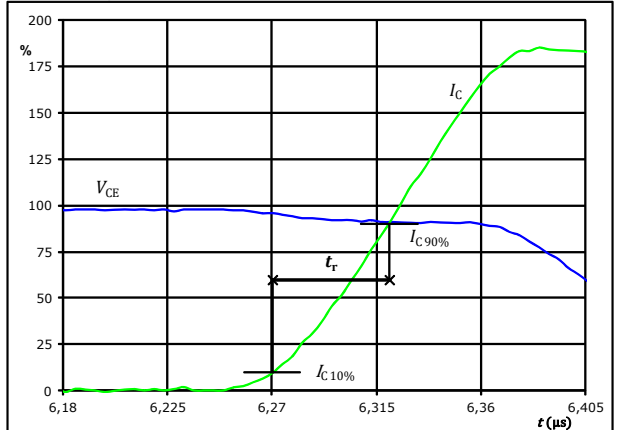

$V_C(100\%) =$	600	V
$I_C(100\%) =$	75	A
$t_r =$	0,050	μs



Vincotech

## Inverter Switching Characteristics

**figure 5.** IGBT

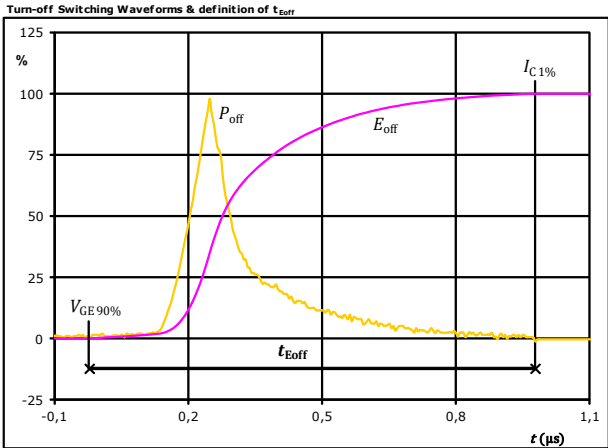

$P_{\text{off}}(100\%) =$	45,05	kW
$E_{\text{off}}(100\%) =$	6,89	mJ
$t_{\text{Eoff}} =$	1,00	μs

**figure 6.** IGBT

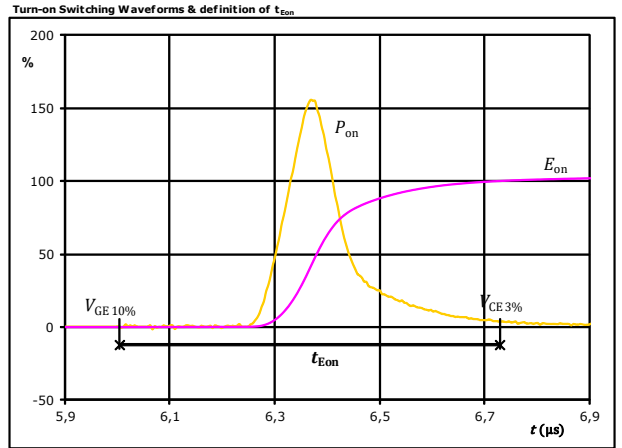

$P_{\text{on}}(100\%) =$	45,05	kW
$E_{\text{on}}(100\%) =$	9,29	mJ
$t_{\text{Eon}} =$	0,73	μs

**figure 7.** FWD

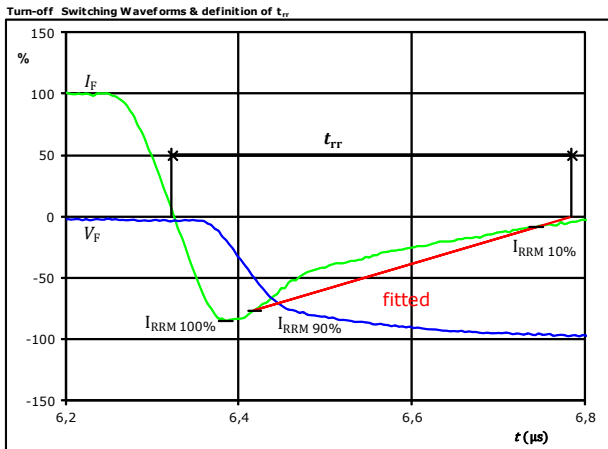

$V_F(100\%) =$	600	V
$I_F(100\%) =$	75	A
$I_{\text{RRM}}(100\%) =$	-64	A
$t_{\text{rr}} =$	0,458	μs



Vincotech

**30-F212PMA075M7-L889A79**  
**30-P212PMA075M7-L889A79Y**  
 datasheet

## Inverter Switching Characteristics

**figure 8.** FWD

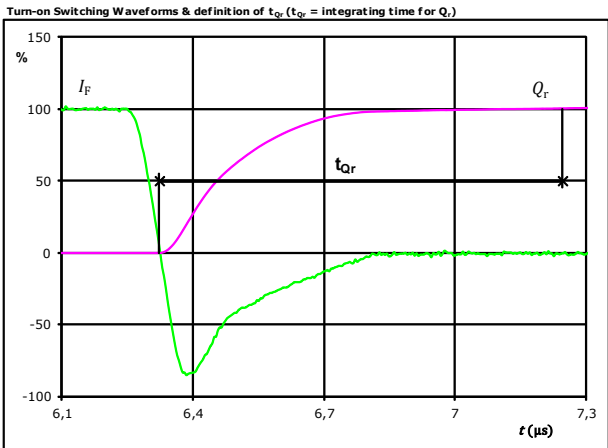

$I_F$ (100%) =	75	A
$Q_r$ (100%) =	12,63	$\mu\text{C}$
$t_{Qr}$ =	0,92	$\mu\text{s}$

**figure 9.** FWD

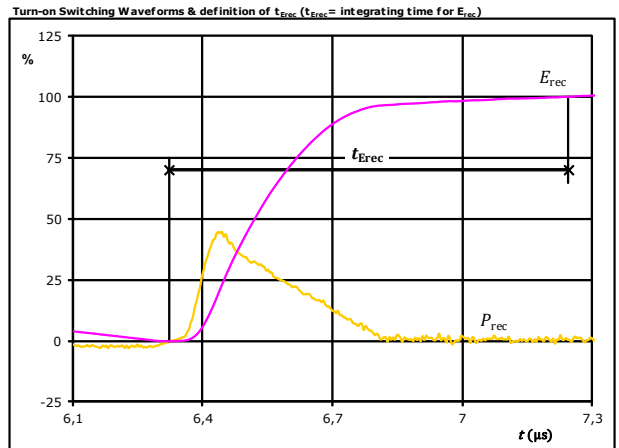

$P_{rec}$ (100%) =	45,05	kW
$E_{rec}$ (100%) =	4,59	mJ
$t_{Erec}$ =	0,92	$\mu\text{s}$





## Brake Switching Characteristics

**figure 1.** IGBT

Typical switching energy losses as a function of collector current

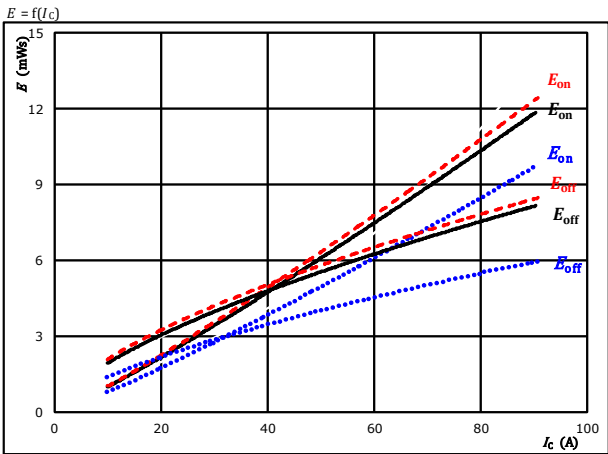

With an inductive load at  
 $V_{CE} = 700$  V  
 $V_{GE} = 15/0$  V  
 $R_{gon} = 8$   $\Omega$   
 $R_{goff} = 8$   $\Omega$

$T_j$ : 25 °C (dotted blue), 125 °C (solid black), 150 °C (dashed red)

**figure 2.** IGBT

Typical switching energy losses as a function of gate resistor

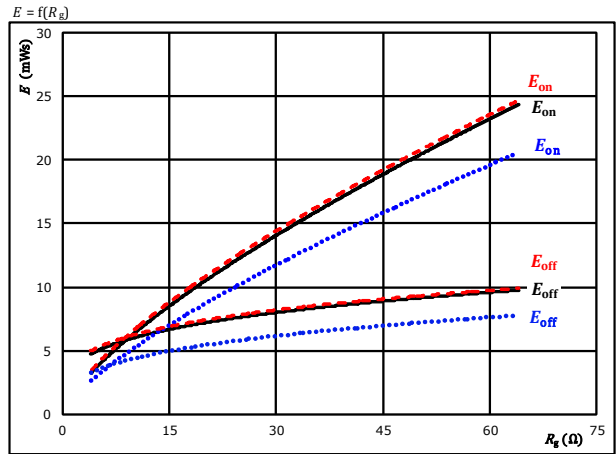

With an inductive load at  
 $V_{CE} = 700$  V  
 $V_{GE} = 15/0$  V  
 $I_C = 50$  A

$T_j$ : 25 °C (dotted blue), 125 °C (solid black), 150 °C (dashed red)

**figure 3.** FWD

Typical reverse recovered energy loss as a function of collector current

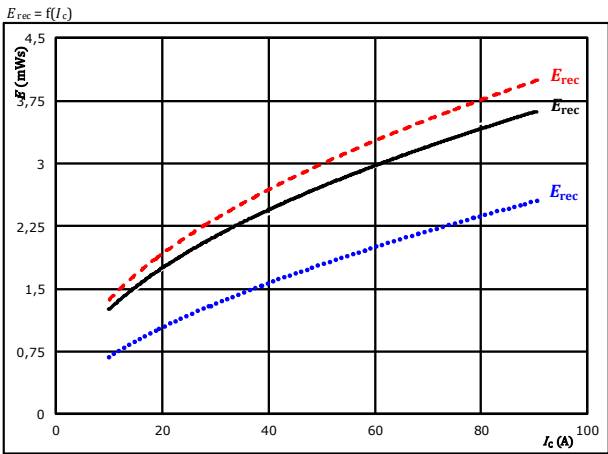

With an inductive load at  
 $V_{CE} = 700$  V  
 $V_{GE} = 15/0$  V  
 $R_{gon} = 8$   $\Omega$

$T_j$ : 25 °C (dotted blue), 125 °C (solid black), 150 °C (dashed red)

**figure 4.** FWD

Typical reverse recovered energy loss as a function of gate resistor

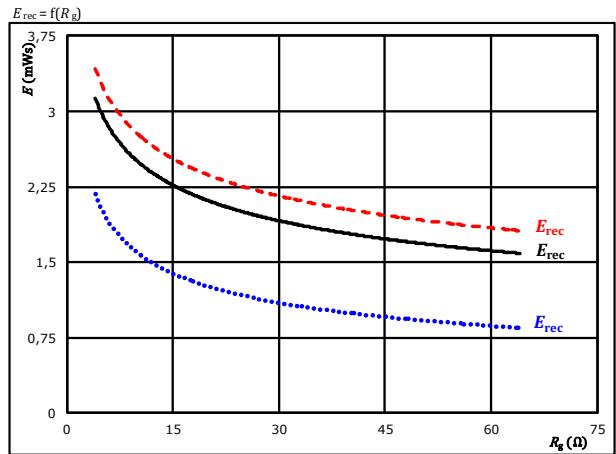

With an inductive load at  
 $V_{CE} = 700$  V  
 $V_{GE} = 15/0$  V  
 $I_C = 50$  A

$T_j$ : 25 °C (dotted blue), 125 °C (solid black), 150 °C (dashed red)



## Brake Switching Characteristics

**figure 5.** IGBT

Typical switching times as a function of collector current

$$t = f(I_c)$$

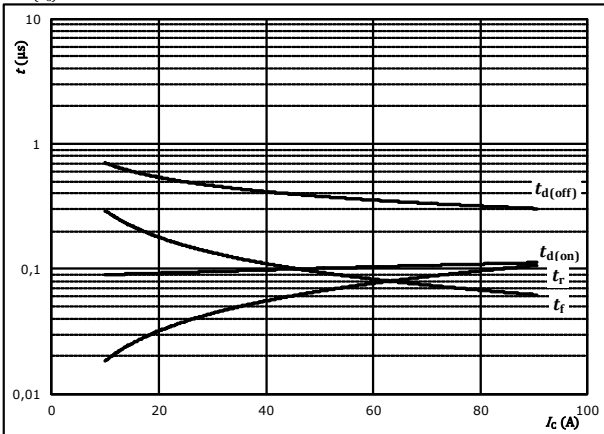

With an inductive load at

$T_j =$	150	°C
$V_{CE} =$	700	V
$V_{GE} =$	15/0	V
$R_{gon} =$	8	Ω
$R_{goff} =$	8	Ω

**figure 6.** IGBT

Typical switching times as a function of gate resistor

$$t = f(R_g)$$

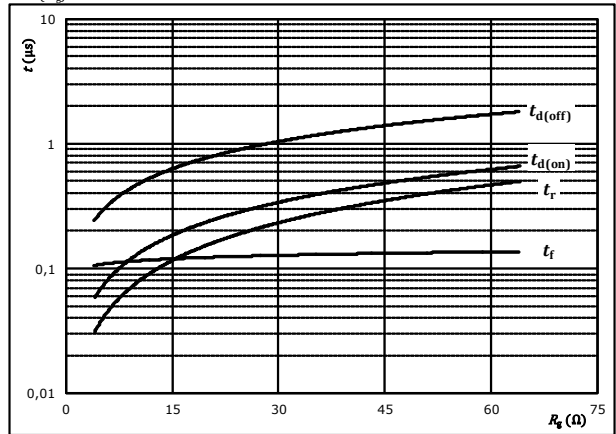

With an inductive load at

$T_j =$	150	°C
$V_{CE} =$	700	V
$V_{GE} =$	15/0	V
$I_c =$	50	A

**figure 7.** FWD

Typical reverse recovery time as a function of collector current

$$t_{rr} = f(I_c)$$

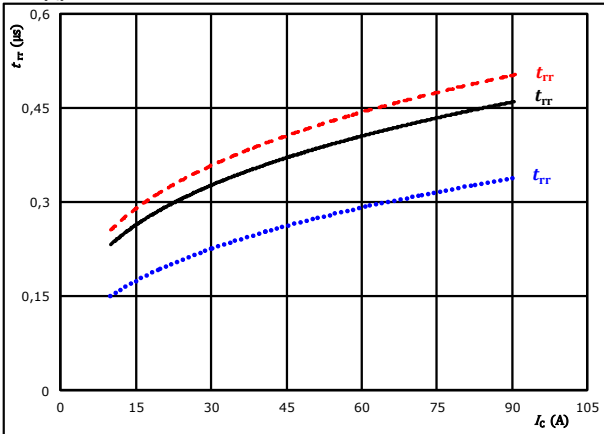

At	$V_{CE} =$	700	V	$T_j:$	25 °C	.....
	$V_{GE} =$	15/0	V		125 °C	————
	$R_{gon} =$	8	Ω		150 °C	-----

**figure 8.** FWD

Typical reverse recovery time as a function of IGBT turn on gate resistor

$$t_{rr} = f(R_{gon})$$

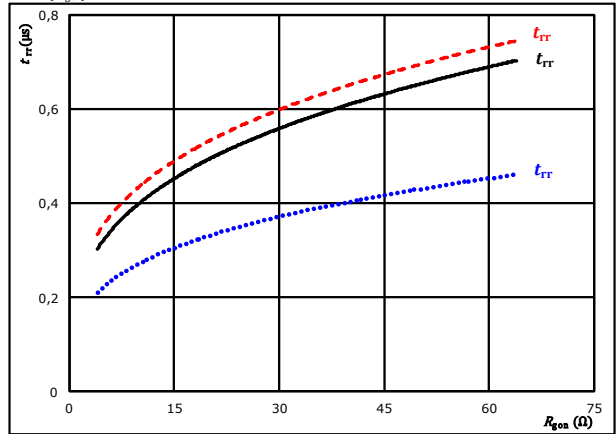

At	$V_{CE} =$	700	V	$T_j:$	25 °C	.....
	$V_{GE} =$	15/0	V		125 °C	————
	$I_c =$	50	A		150 °C	-----



## Brake Switching Characteristics

**figure 9.** FWD

Typical recovered charge as a function of collector current

$$Q_r = f(I_c)$$

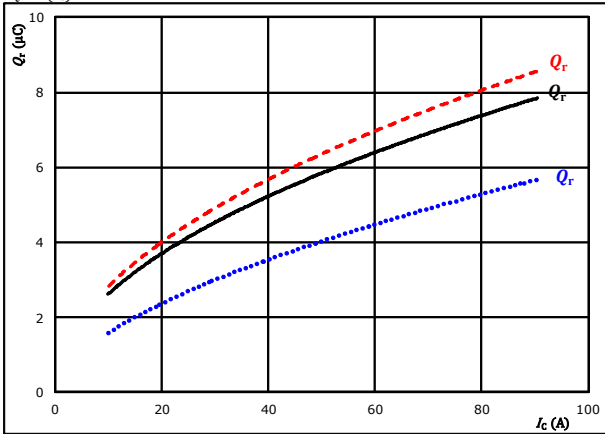

At  $V_{CE} = 700$  V  $T_j = 25$  °C .....  
 $V_{GE} = 15/0$  V  $T_j = 125$  °C ———  
 $R_{gpn} = 8$  Ω  $T_j = 150$  °C - - - - -

**figure 10.** FWD

Typical recovered charge as a function of IGBT turn on gate resistor

$$Q_r = f(R_{gpn})$$

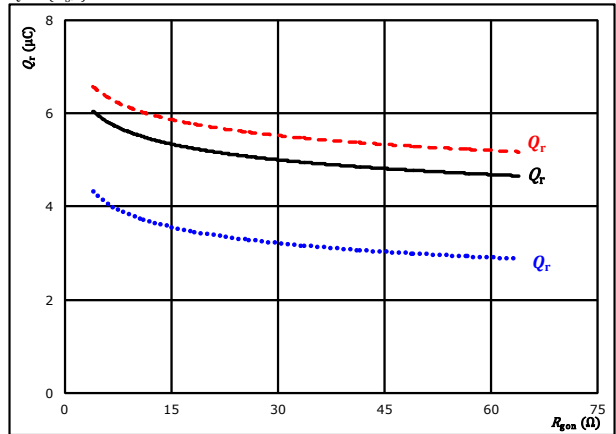

At  $V_{CE} = 700$  V  $T_j = 25$  °C .....  
 $V_{GE} = 15/0$  V  $T_j = 125$  °C ———  
 $I_c = 50$  A  $T_j = 150$  °C - - - - -

**figure 11.** FWD

Typical peak reverse recovery current current as a function of collector current

$$I_{RM} = f(I_c)$$

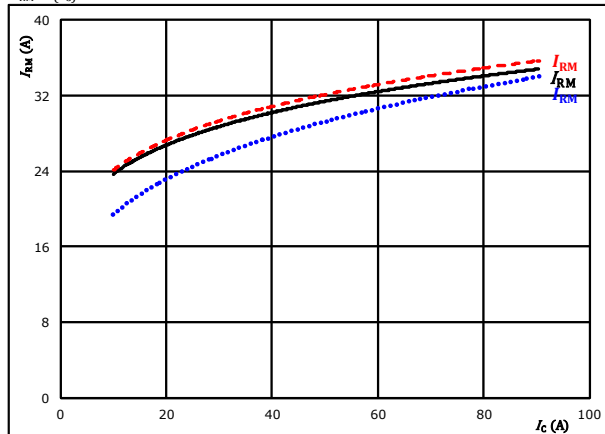

At  $V_{CE} = 700$  V  $T_j = 25$  °C .....  
 $V_{GE} = 15/0$  V  $T_j = 125$  °C ———  
 $R_{gpn} = 8$  Ω  $T_j = 150$  °C - - - - -

**figure 12.** FWD

Typical peak reverse recovery current current as a function of IGBT turn on gate resistor

$$I_{RM} = f(R_{gpn})$$

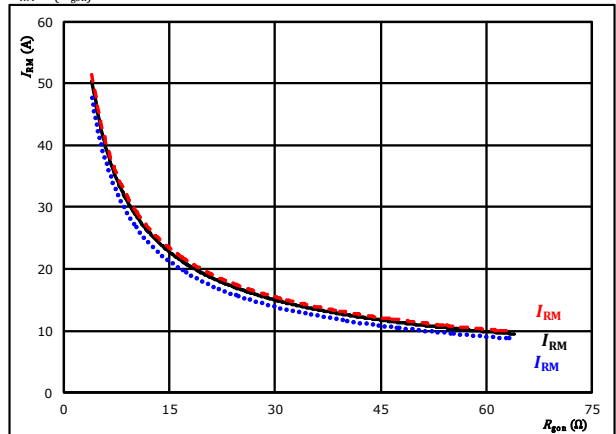

At  $V_{CE} = 700$  V  $T_j = 25$  °C .....  
 $V_{GE} = 15/0$  V  $T_j = 125$  °C ———  
 $I_c = 50$  A  $T_j = 150$  °C - - - - -



## Brake Switching Characteristics

**figure 13.** FWD

Typical rate of fall of forward and reverse recovery current as a function of collector current  
 $di_f/dt, di_{rr}/dt = f(I_c)$

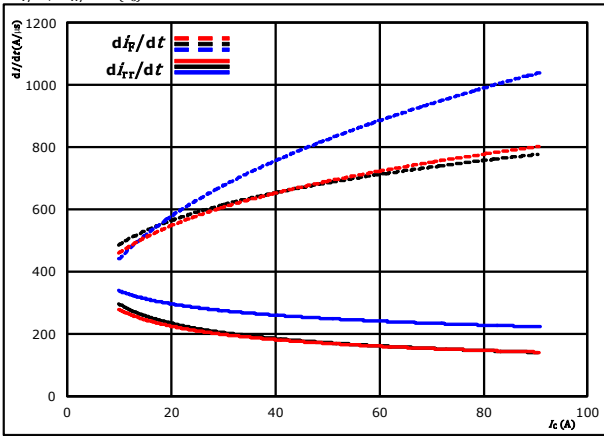

At  $V_{CE} = 700$  V  $T_j = 25$  °C .....  
 $V_{GE} = 15/0$  V  $T_j = 125$  °C ———  
 $R_{g(on)} = 8$  Ω  $T_j = 150$  °C - - - - -

**figure 14.** FWD

Typical rate of fall of forward and reverse recovery current as a function of IGBT turn on gate resistor  
 $di_f/dt, di_{rr}/dt = f(R_{g(on)})$

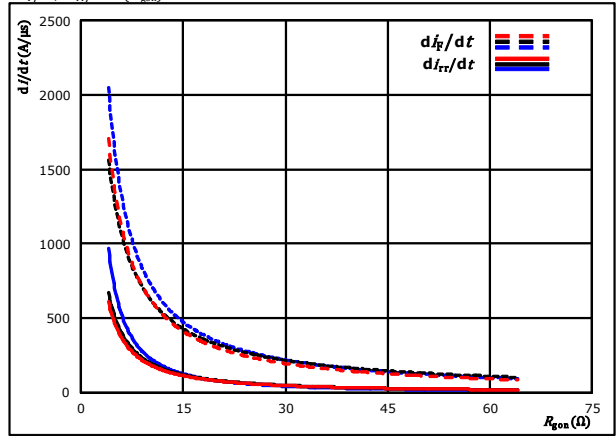

At  $V_{CE} = 700$  V  $T_j = 25$  °C .....  
 $V_{GE} = 15/0$  V  $T_j = 125$  °C ———  
 $I_c = 50$  A  $T_j = 150$  °C - - - - -

**figure 15.** IGBT

Reverse bias safe operating area

$I_c = f(V_{CE})$

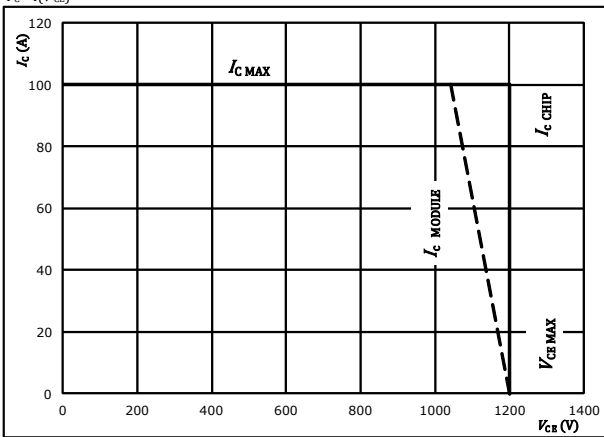

At  $T_j = 175$  °C  
 $R_{g(on)} = 8$  Ω  
 $R_{g(off)} = 8$  Ω



## Brake Switching Definitions

**General conditions**

$T_j$	=	125 °C
$R_{gon}$	=	8 Ω
$R_{goff}$	=	8 Ω

**figure 1.** IGBT

Turn-off Switching Waveforms & definition of  $t_{doff}$ ,  $t_{Eoff}$  ( $t_{Eoff}$  = integrating time for  $E_{off}$ )

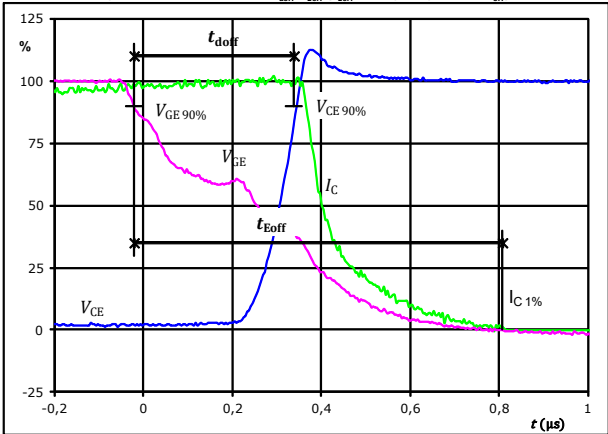

$V_{CE}(0\%) =$	0	V
$V_{GE}(100\%) =$	15	V
$V_C(100\%) =$	700	V
$I_C(100\%) =$	50	A
$t_{doff} =$	0,369	$\mu s$
$t_{Eoff} =$	0,829	$\mu s$

**figure 2.** IGBT

Turn-on Switching Waveforms & definition of  $t_{don}$ ,  $t_{Eon}$  ( $t_{Eon}$  = integrating time for  $E_{on}$ )

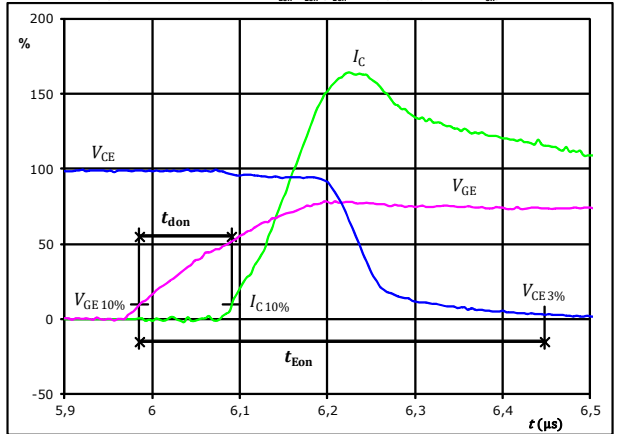

$V_{CE}(0\%) =$	0	V
$V_{GE}(100\%) =$	15	V
$V_C(100\%) =$	700	V
$I_C(100\%) =$	50	A
$t_{don} =$	0,105	$\mu s$
$t_{Eon} =$	0,462	$\mu s$

**figure 3.** IGBT

Turn-off Switching Waveforms & definition of  $t_r$

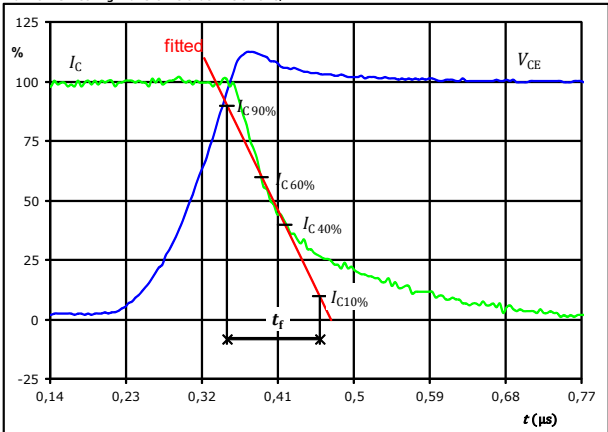

$V_C(100\%) =$	700	V
$I_C(100\%) =$	50	A
$t_r =$	0,117	$\mu s$

**figure 4.** IGBT

Turn-on Switching Waveforms & definition of  $t_r$

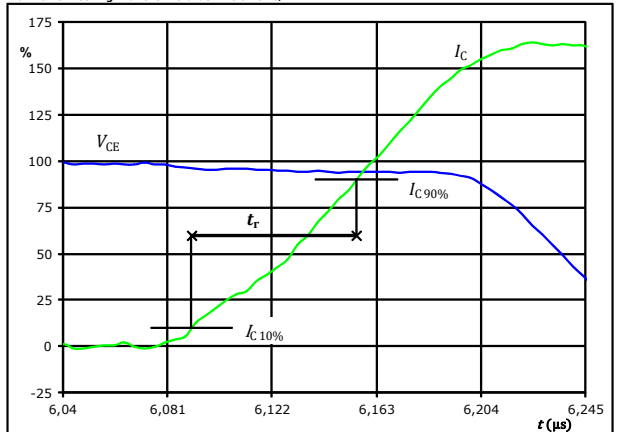

$V_C(100\%) =$	700	V
$I_C(100\%) =$	50	A
$t_r =$	0,064	$\mu s$



## Brake Switching Characteristics

**figure 5.** IGBT

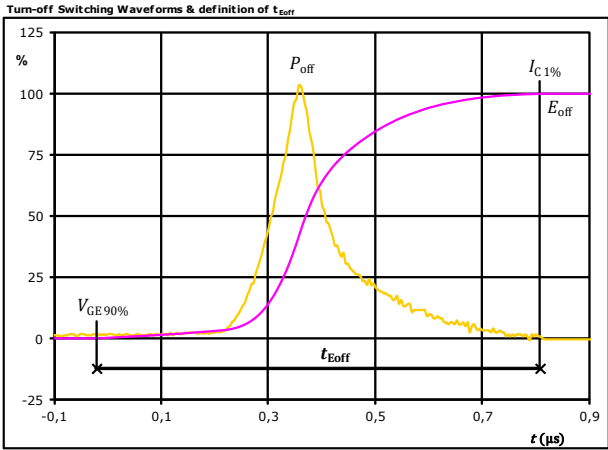

$P_{off}(100\%) = 35,10$  kW  
 $E_{off}(100\%) = 5,48$  mJ  
 $t_{Eoff} = 0,83$  µs

**figure 6.** IGBT

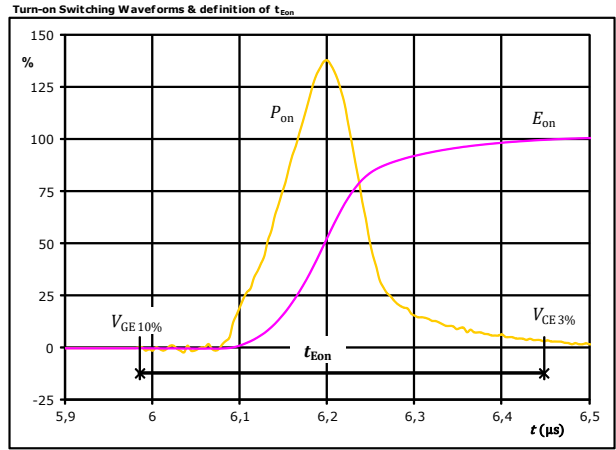

$P_{on}(100\%) = 35,10$  kW  
 $E_{on}(100\%) = 5,50$  mJ  
 $t_{Eon} = 0,46$  µs

**figure 7.** FWD

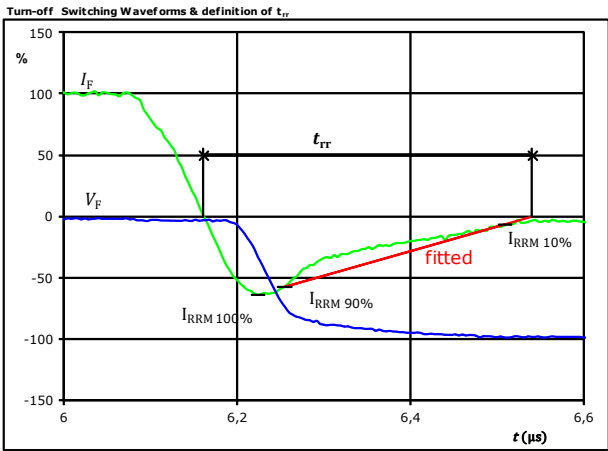

$V_F(100\%) = 700$  V  
 $I_F(100\%) = 50$  A  
 $I_{RRM}(100\%) = -32$  A  
 $t_{rr} = 0,375$  µs



Vincotech

**30-F212PMA075M7-L889A79**  
**30-P212PMA075M7-L889A79Y**  
 datasheet

## Brake Switching Characteristics

**figure 8.** FWD

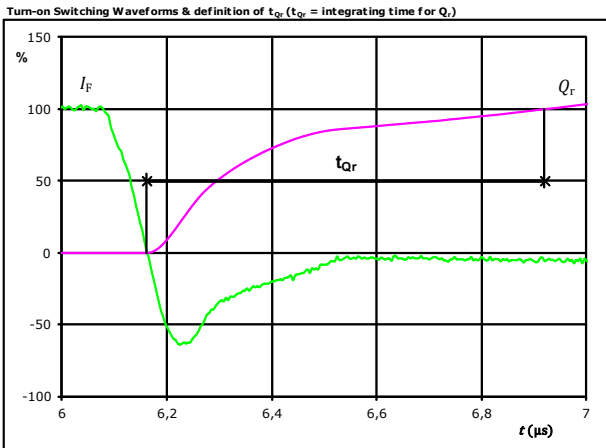

$I_F$  (100%) = 50 A  
 $Q_r$  (100%) = 5,59  $\mu\text{C}$   
 $t_{Qr}$  = 0,76  $\mu\text{s}$

**figure 9.** FWD

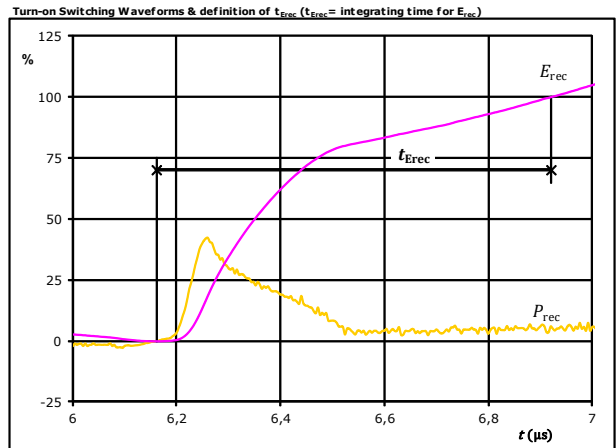

$P_{rec}$  (100%) = 35,10 kW  
 $E_{rec}$  (100%) = 2,62 mJ  
 $t_{Erec}$  = 0,76  $\mu\text{s}$



# 30-F212PMA075M7-L889A79 30-P212PMA075M7-L889A79Y

datasheet

Vincotech

Ordering Code & Marking								
Version			Ordering Code					
without thermal paste 17 mm housing with solder pins			30-F212PMA075M7-L889A79					
with thermal paste 17 mm housing with solder pins			30-F212PMA075M7-L889A79-/3/					
without thermal paste 17 mm housing with press-fit pins			30-P212PMA075M7-L889A79Y					
with thermal paste 17 mm housing with press-fit pins			30-P212PMA075M7-L889A79Y-/3/					
NN-NNNNNNNNNNNNNN TTTTIVVWWYY UL VIN LLLLL SSSS			<b>Text</b>	<b>Name</b>	<b>Date code</b>	<b>UL &amp; VIN</b>	<b>Lot</b>	<b>Serial</b>
				NN-NNNNNNNNNNNNNN-TTTTIVV	WWYY	UL VIN	LLLLL	SSSS
			<b>Datamatrix</b>	<b>Type&amp;Ver</b>	<b>Lot number</b>	<b>Serial</b>	<b>Date code</b>	
			TTTTIVV	LLLLL	SSSS	WWYY		

Outline							
Pin table							
Pin	X	Y	Function	Pin	X	Y	Function
1	71,2	0	DC-Rect	52	71,2	20,2	ACIn3
2	68,7	0	DC-Rect	53	71,2	12,8	Br
3	66,2	0	DC-Rect	54	68,7	12,8	Br
4	63,7	0	DC-Rect	55	71,2	5,6	G27
5	55,95	0	DC+Rect	56	71,2	2,8	DC-Br
6	53,45	0	DC+Rect	52	71,2	20,2	ACIn3
7	55,95	2,8	DC+Rect	53	71,2	12,8	Br
8	53,45	2,8	DC+Rect	54	68,7	12,8	Br
9	48,4	0	DC+Inv1	55	71,2	5,6	G27
10	45,9	0	DC+Inv1	56	71,2	2,8	DC-Br
11	38,9	0	S11				
12	36,1	0	DC-1				
13	38,9	2,8	G11				
14	36,1	2,8	DC-1				
15	31,3	0	DC-2				
16	28,5	0	S13				
17	31,3	2,8	DC-2				
18	28,5	2,8	G13				
19	19,3	0	Therm2				
20	19,3	2,8	Therm1				
21	12,3	0	DC+Inv2				
22	9,8	0	DC+Inv2				
23	12,3	2,8	DC+Inv2				
24	9,8	2,8	DC+Inv2				
25	2,8	0	S15				
26	0	0	DC-3				
27	2,8	2,8	G15				
28	0	2,8	DC-3				
29	0	37,2	Ph3				
30	2,5	37,2	Ph3				
31	5	37,2	Ph3				
32	7,8	37,2	S16				
33	10,6	37,2	G16				
34	18,45	37,2	G14				
35	21,25	37,2	S14				
36	24,05	37,2	Ph2				
37	26,55	37,2	Ph2				
38	29,05	37,2	Ph2				
39	36,1	37,2	Ph1				
40	38,6	37,2	Ph1				
41	41,1	37,2	Ph1				
42	43,9	37,2	S12				
43	46,7	37,2	G12				
44	53,7	37,2	ACIn1				
45	56,2	37,2	ACIn1				
46	58,7	37,2	ACIn1				
47	71,2	37,2	ACIn2				
48	71,2	34,7	ACIn2				
49	71,2	32,2	ACIn2				
50	71,2	25,2	ACIn3				
51	71,2	22,7	ACIn3				

**Solder pins**

**Press-fit**

**Top View**

Tolerance of pinpositions  $\pm 0.5\text{mm}$  at the end of pins  
Dimension of coordinate axis is only offset without tolerance



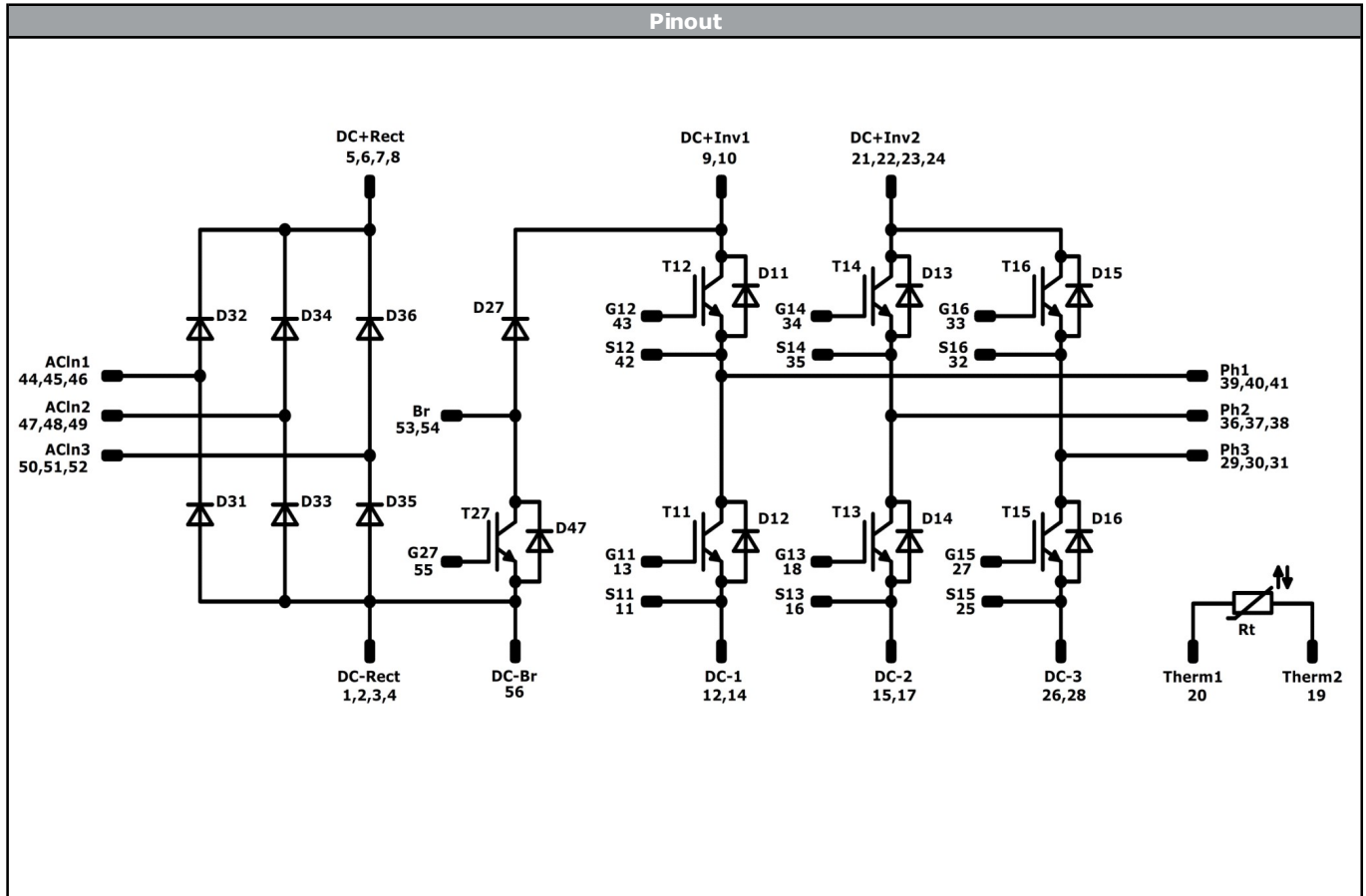

<b>Identification</b>					
<b>ID</b>	<b>Component</b>	<b>Voltage</b>	<b>Current</b>	<b>Function</b>	<b>Comment</b>
D31, D32, D33, D34, D35, D36	Rectifier	1600 V	75 A	Rectifier Diode	
T11, T12, T13, T14, T15, T16	IGBT	1200 V	75 A	Inverter Switch	
D11, D12, D13, D14, D15, D16	FWD	1200 V	100 A	Inverter Diode	
T27	IGBT	1200 V	50 A	Brake Switch	
D27	FWD	1200 V	25 A	Brake Diode	
D47	FWD	1200 V	5 A	Brake Sw. Protection Diode	
Rt	NTC			Thermistor	



Vincotech

Packaging instruction			
Standard packaging quantity (SPQ) 36	>SPQ	Standard	<SPQ Sample

Handling instruction
Handling instructions for <i>flow 2</i> packages see vincotech.com website.

Package data
Package data for <i>flow 2</i> packages see vincotech.com website.

UL recognition and file number
This device is certified according to UL 1557 standard, UL file number E192116. For more information see vincotech.com website. 

Document No.:	Date:	Modification:	Pages
30-x212PMA075M7-L889A79x-D1-14	18 Dec. 2017		

**DISCLAIMER**

The information, specifications, procedures, methods and recommendations herein (together "information") are presented by Vincotech to reader in good faith, are believed to be accurate and reliable, but may well be incomplete and/or not applicable to all conditions or situations that may exist or occur. Vincotech reserves the right to make any changes without further notice to any products to improve reliability, function or design. No representation, guarantee or warranty is made to reader as to the accuracy, reliability or completeness of said information or that the application or use of any of the same will avoid hazards, accidents, losses, damages or injury of any kind to persons or property or that the same will not infringe third parties rights or give desired results. It is reader's sole responsibility to test and determine the suitability of the information and the product for reader's intended use.

**LIFE SUPPORT POLICY**

Vincotech products are not authorised for use as critical components in life support devices or systems without the express written approval of Vincotech.

As used herein:

1. Life support devices or systems are devices or systems which, (a) are intended for surgical implant into the body, or (b) support or sustain life, or (c) whose failure to perform when properly used in accordance with instructions for use provided in labelling can be reasonably expected to result in significant injury to the user.
2. A critical component is any component of a life support device or system whose failure to perform can be reasonably expected to cause the failure of the life support device or system, or to affect its safety or effectiveness.