

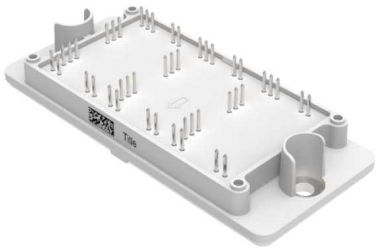
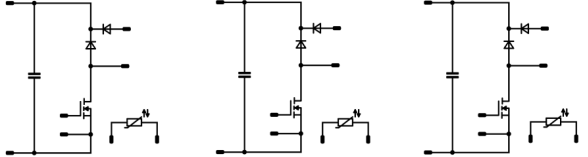

Vincotech

| <i>flow 3xBOOST 2 SiC</i> | 1200 V / 40 mΩ |
|---|--|
| <div style="background-color: #eee; padding: 2px; margin-bottom: 5px;">Features</div> <ul style="list-style-type: none"> Three-leg Booster module Full SiC for ultra fast switching frequency Low inductive package Ultra high efficient | <div style="background-color: #eee; padding: 2px; margin-bottom: 5px;">flow 2 13mm housing</div>  |
| <div style="background-color: #eee; padding: 2px; margin-bottom: 5px;">Target applications</div> <ul style="list-style-type: none"> Solar | <div style="background-color: #eee; padding: 2px; margin-bottom: 5px;">Schematic</div>  |
| <div style="background-color: #eee; padding: 2px; margin-bottom: 5px;">Types</div> <ul style="list-style-type: none"> 30-FT123BA040MR-L878L08 | |

Maximum Ratings

$T_j = 25\text{ °C}$, unless otherwise specified

| Parameter | Symbol | Condition | Value | Unit |
|------------------------------|------------|---------------------------------------|-------|------|
| Boost Switch | | | | |
| Drain-source voltage | V_{DSS} | | 1200 | V |
| Drain current | I_D | $T_j = T_{jmax}$ $T_s = 80\text{ °C}$ | 31 | A |
| Peak drain current | I_{DM} | t_p limited by T_{jmax} | 137 | A |
| Total power dissipation | P_{tot} | $T_j = T_{jmax}$ $T_s = 80\text{ °C}$ | 66 | W |
| Gate-source voltage | V_{GSS} | | -4/22 | V |
| Maximum Junction Temperature | T_{jmax} | | 175 | °C |



Vincotech

Maximum Ratings

$T_j = 25\text{ °C}$, unless otherwise specified

| Parameter | Symbol | Condition | Value | Unit |
|-------------------------------------|------------|---------------------------------------|-------|------|
| Boost Diode | | | | |
| Peak Repetitive Reverse Voltage | V_{RRM} | | 1200 | V |
| Continuous (direct) forward current | I_F | $T_j = T_{jmax}$ $T_s = 80\text{ °C}$ | 39 | A |
| Total power dissipation | P_{tot} | $T_j = T_{jmax}$ $T_s = 80\text{ °C}$ | 93 | W |
| Maximum Junction Temperature | T_{jmax} | | 175 | °C |

ByPass Diode

| | | | | |
|--|------------|---|------|------------------|
| Peak Repetitive Reverse Voltage | V_{RRM} | | 1600 | V |
| Continuous (direct) forward current | I_F | $T_j = T_{jmax}$ $T_s = 80\text{ °C}$ | 53 | A |
| Surge (non-repetitive) forward current | I_{FSM} | 50 Hz Single Half Sine Wave $t_p = 10\text{ ms}$ $T_j = 150\text{ °C}$ | 490 | A |
| Surge current capability | I^2t | | 1200 | A ² s |
| Total power dissipation | P_{tot} | $T_j = T_{jmax}$ $T_s = 80\text{ °C}$ | 86 | W |
| Maximum Junction Temperature | T_{jmax} | | 150 | °C |

Capacitor (DC)

| | | | | |
|-----------------------|-----------|--|------------|----|
| Maximum DC voltage | V_{MAX} | | 1500 | V |
| Operation Temperature | T_{op} | | -55...+125 | °C |

Module Properties

Thermal Properties

| | | | | |
|---|-----------|--|---------------------------|----|
| Storage temperature | T_{stg} | | -40...+125 | °C |
| Operation temperature under switching condition | T_{jop} | | -40...($T_{jmax} - 25$) | °C |

Isolation Properties

| | | | | |
|----------------------------|------------|------------------------------------|-----------|----|
| Isolation voltage | V_{isol} | DC Test Voltage $t_p = 2\text{ s}$ | 4000 | V |
| Creepage distance | | | min. 12,7 | mm |
| Clearance | | | min. 12,7 | mm |
| Comparative Tracking Index | CTI | | > 200 | |



Vincotech

Characteristic Values

| Parameter | Symbol | Conditions | | | | | Value | | | Unit |
|-----------|--------|--------------|--------------|--------------|-----------|------------|-------|-----|-----|------|
| | | V_{GS} [V] | V_{GE} [V] | V_{DS} [V] | I_C [A] | T_j [°C] | Min | Typ | Max | |

Boost Switch

Static

| Parameter | Symbol | V_{GS} [V] | V_{GE} [V] | V_{DS} [V] | I_C [A] | T_j [°C] | Min | Typ | Max | Unit |
|----------------------------------|--------------|-------------------|--------------|--------------|-----------|------------------|-----|----------------|-------------|------|
| Drain-source on-state resistance | $r_{DS(on)}$ | 18 | | | 20 | 25 125 150 | | 39 52 60 | 50 | mΩ |
| Gate-source threshold voltage | $V_{GS(th)}$ | $V_{GS} = V_{DS}$ | | | 0,01 | 25 | 2,7 | | 5,6 | V |
| Gate to Source Leakage Current | I_{GSS} | 22 -4 | 0 | | | 25 | | | 100 -100 | nA |
| Zero Gate Voltage Drain Current | I_{DSS} | 0 | 1200 | | | 25 | | | 10 | μA |
| Internal gate resistance | r_g | | | | | | | 7 | | Ω |
| Gate charge | Q_g | | | | | | | 107 | | nC |
| Gate to source charge | Q_{GS} | 18 | 600 | 20 | 25 | | | 22 | | |
| Gate to drain charge | Q_{GD} | | | | | | | 41 | | |
| Short-circuit input capacitance | C_{iss} | | | | | | | 1337 | | pF |
| Short-circuit output capacitance | C_{oss} | $f = 1$ MHz | | 0 | 800 | 25 | | 76 | | |
| Reverse transfer capacitance | C_{rss} | | | | | | | 27 | | |

Thermal

| | | | | | | | | | | |
|-------------------------------------|---------------|---|--|--|--|--|--|------|--|-----|
| Thermal resistance junction to sink | $R_{th(j-s)}$ | phase-change material $\lambda = 3,4$ W/mK | | | | | | 1,45 | | K/W |
|-------------------------------------|---------------|---|--|--|--|--|--|------|--|-----|

Boost Diode

Static

| Parameter | Symbol | V_{GS} [V] | V_{GE} [V] | V_{DS} [V] | I_C [A] | T_j [°C] | Min | Typ | Max | Unit |
|-------------------------|--------|--------------|--------------|--------------|-----------|------------------|-----|----------------------|-----|------|
| Forward voltage | V_F | | | | 30 | 25 125 150 | | 1,43 1,76 1,89 | 1,4 | V |
| Reverse leakage current | I_r | | | 1200 | | 25 | | | 600 | μA |

Thermal

| | | | | | | | | | | |
|-------------------------------------|---------------|---|--|--|--|--|--|------|--|-----|
| Thermal resistance junction to sink | $R_{th(j-s)}$ | phase-change material $\lambda = 3,4$ W/mK | | | | | | 1,02 | | K/W |
|-------------------------------------|---------------|---|--|--|--|--|--|------|--|-----|



Vincotech

Characteristic Values

| Parameter | Symbol | Conditions | | | | | Value | | | Unit |
|-----------|--------|--------------|--------------|--------------|-----------|------------|-------|-----|-----|------|
| | | V_{GS} [V] | V_{GE} [V] | V_{DS} [V] | I_D [A] | T_j [°C] | Min | Typ | Max | |

ByPass Diode

Static

| Parameter | Symbol | V_{GS} [V] | V_{GE} [V] | V_{DS} [V] | I_D [A] | T_j [°C] | Min | Typ | Max | Unit |
|-------------------------|--------|--------------|--------------|--------------|-----------|------------|-----|--------------|------------|---------|
| Forward voltage | V_F | | | | 50 | 25 125 | | 1,22 1,48 | 1,8 | V |
| Reverse leakage current | I_r | | | 1600 | | 25 150 | | | 50 1100 | μ A |

Thermal

| Parameter | Symbol | Conditions | Min | Typ | Max | Unit |
|-------------------------------------|---------------|---|-----|-----|-----|-------------|
| Thermal resistance junction to sink | $R_{th(j-s)}$ | phase-change material $\lambda = 3,4$ W/mK | | | | 0,82 K/W |

Capacitor (DC)

| Parameter | Symbol | Conditions | Min | Typ | Max | Unit |
|-------------|--------|------------|-----|-----|-----|------|
| Capacitance | C | | | 78 | | nF |
| Tolerance | | | -10 | | +10 | % |

Thermistor

| Parameter | Symbol | Conditions | Min | Typ | Max | Unit |
|----------------------------|----------------|----------------------|-----|-----|---------|------------|
| Rated resistance | R | | | 25 | 22 | k Ω |
| Deviation of R100 | $\Delta_{R/R}$ | R100 = 1484 Ω | | 100 | -5 5 | % |
| Power dissipation | P | | | 25 | 5 | mW |
| Power dissipation constant | | | | 25 | 1,5 | mW/K |
| B-value | $B_{(25/50)}$ | Tol. $\pm 1\%$ | | 25 | 3962 | K |
| B-value | $B_{(25/100)}$ | Tol. $\pm 1\%$ | | 25 | 4000 | K |
| Vincotech NTC Reference | | | | | I | |



Vincotech

| Ordering Code & Marking | | | | | | | |
|---|------------|------------------------------|------------|-------------------------|-----------|------|--------|
| Version | | | | Ordering Code | | | |
| without thermal paste 13mm housing with solder pins | | | | 30-FT123BA040MR-L878L08 | | | |
| | Text | Name | | Date code | UL & VIN | Lot | Serial |
| | | NN-NNNNNNNNNNNNNNNNNN-TTTTIV | | WWYY | UL VIN | LLLL | SSSS |
| | Datamatrix | Type&Ver | Lot number | Serial | Date code | | |
| | | TTTTTIV | LLLL | SSSS | WWYY | | |

| Outline | | | | | | | |
|----------------|------|------|-----------|----------------|------|------|-----------|
| Pin table [mm] | | | | Pin table [mm] | | | |
| Pin | X | Y | Function | Pin | X | Y | Function |
| 1 | 69,1 | 0 | G29 | 30 | 0 | 26,1 | DC+Boost1 |
| 2 | 66,1 | 0 | S29 | 31 | 0 | 35,2 | Boost1 |
| 3 | 53,6 | 0 | Therm31 | 32 | 2,5 | 35,2 | Boost1 |
| 4 | 50,6 | 0 | Therm32 | 33 | 5 | 35,2 | Boost1 |
| 5 | 43,8 | 0 | G27 | 34 | 13,8 | 35,2 | DC+In1 |
| 6 | 40,8 | 0 | S27 | 35 | 16,3 | 35,2 | DC+In1 |
| 7 | 28,3 | 0 | Therm21 | 36 | 25,3 | 35,2 | Boost2 |
| 8 | 25,3 | 0 | Therm22 | 37 | 27,8 | 35,2 | Boost2 |
| 9 | 18,5 | 0 | G25 | 38 | 30,3 | 35,2 | Boost2 |
| 10 | 15,5 | 0 | S25 | 39 | 39,1 | 35,2 | DC+In2 |
| 11 | 3 | 0 | Therm11 | 40 | 41,6 | 35,2 | DC+In2 |
| 12 | 0 | 0 | Therm12 | 41 | 50,6 | 35,2 | Boost3 |
| 13 | 0 | 4,1 | DC-Boost1 | 42 | 53,1 | 35,2 | Boost3 |
| 14 | 0 | 6,6 | DC-Boost1 | 43 | 55,6 | 35,2 | Boost3 |
| 15 | 0 | 9,1 | DC-Boost1 | 44 | 64,4 | 35,2 | DC+In3 |
| 16 | 25,3 | 4,1 | DC-Boost2 | 45 | 66,9 | 35,2 | DC+In3 |
| 17 | 25,3 | 6,6 | DC-Boost2 | | | | |
| 18 | 25,3 | 9,1 | DC-Boost2 | | | | |
| 19 | 50,6 | 4,1 | DC-Boost3 | | | | |
| 20 | 50,6 | 6,6 | DC-Boost3 | | | | |
| 21 | 50,6 | 9,1 | DC-Boost3 | | | | |
| 22 | 50,6 | 21,1 | DC+Boost3 | | | | |
| 23 | 50,6 | 23,6 | DC+Boost3 | | | | |
| 24 | 50,6 | 26,1 | DC+Boost3 | | | | |
| 25 | 25,3 | 21,1 | DC+Boost2 | | | | |
| 26 | 25,3 | 23,6 | DC+Boost2 | | | | |
| 27 | 25,3 | 26,1 | DC+Boost2 | | | | |
| 28 | 0 | 21,1 | DC+Boost1 | | | | |
| 29 | 0 | 23,6 | DC+Boost1 | | | | |

Tolerance of pinpositions: ±0,5mm at the end of pins
Dimension of coordinate axis is only offset without tolerance



Vincotech

Pinout

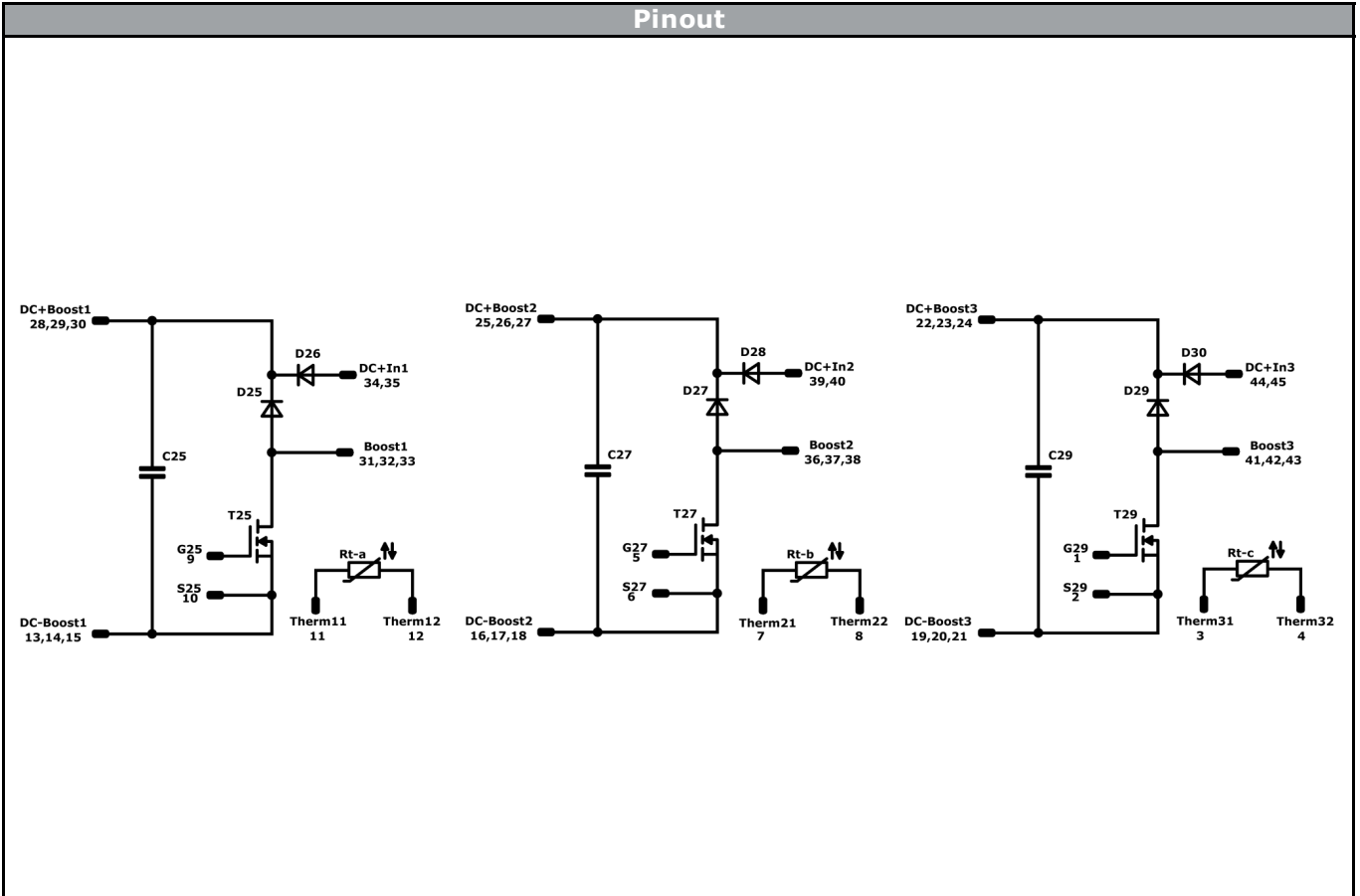

Identification

| ID | Component | Voltage | Current | Function | Comment |
|------------------|------------|---------|---------|----------------|---------|
| T25, T27, T29 | MOSFET | 1200 V | 40 mΩ | Boost Switch | |
| D25, D27, D29 | FWD | 1200 V | 30 A | Boost Diode | |
| D26, D28, D30 | Rectifier | 1600 V | 50 A | ByPass Diode | |
| C25, C27, C29 | Capacitor | 1500 V | | Capacitor (DC) | |
| Rt-a, Rt-b, Rt-c | Thermistor | | | Thermistor | |



Vincotech

| Packaging instruction | | | |
|--------------------------------------|------|----------|-------------|
| Standard packaging quantity (SPQ) 42 | >SPQ | Standard | <SPQ Sample |

| Handling instruction |
|---|
| Handling instructions for <i>flow 2</i> packages see vincotech.com website. |

| Package data |
|--|
| Package data for <i>flow 2</i> packages see vincotech.com website. |

| UL recognition and file number |
|---|
| This device is certified according to UL 1557 standard, UL file number E192116. For more information see vincotech.com website.  |

| Document No.: | Date: | Modification: | Pages |
|-------------------------------|--------------|---------------|-------|
| 30-FT123BA040MR-L878L08-T1-14 | 20 Apr. 2016 | | |

| Product status definition | | |
|---------------------------|------------------------|--|
| Datasheet Status | Product Status | Definition |
| Target | Formative or In Design | This datasheet contains the design specifications for product development. Specifications may change in any manner without notice. The data contained is exclusively intended for technically trained staff. |

DISCLAIMER

The information, specifications, procedures, methods and recommendations herein (together "information") are presented by Vincotech to reader in good faith, are believed to be accurate and reliable, but may well be incomplete and/or not applicable to all conditions or situations that may exist or occur. Vincotech reserves the right to make any changes without further notice to any products to improve reliability, function or design. No representation, guarantee or warranty is made to reader as to the accuracy, reliability or completeness of said information or that the application or use of any of the same will avoid hazards, accidents, losses, damages or injury of any kind to persons or property or that the same will not infringe third parties rights or give desired results. It is reader's sole responsibility to test and determine the suitability of the information and the product for reader's intended use.

LIFE SUPPORT POLICY

Vincotech products are not authorised for use as critical components in life support devices or systems without the express written approval of Vincotech.

As used herein:

1. Life support devices or systems are devices or systems which, (a) are intended for surgical implant into the body, or (b) support or sustain life, or (c) whose failure to perform when properly used in accordance with instructions for use provided in labelling can be reasonably expected to result in significant injury to the user.
2. A critical component is any component of a life support device or system whose failure to perform can be reasonably expected to cause the failure of the life support device or system, or to affect its safety or effectiveness.