

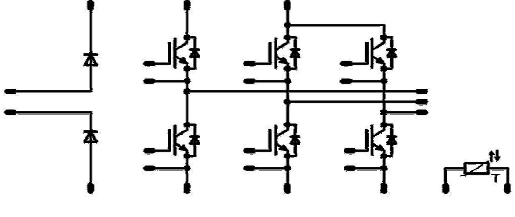





Vincotech

flowPACK 2	600V/75A										
<table border="1" style="width:100%; border-collapse: collapse;"> <tr> <th style="background-color: #cccccc;">Features</th> </tr> <tr> <td> <ul style="list-style-type: none"> Inverter, blocking diodes Built-in thermistor IGBT4 technology for low saturation losses </td> </tr> <tr> <th style="background-color: #cccccc;">Target Applications</th> </tr> <tr> <td> <ul style="list-style-type: none"> Power Regeneration </td> </tr> <tr> <th style="background-color: #cccccc;">Types</th> </tr> <tr> <td> <ul style="list-style-type: none"> 30-F206R6A075SB-M443E 30-F206R6A075SB01-M443E10 </td> </tr> </table>	Features	<ul style="list-style-type: none"> Inverter, blocking diodes Built-in thermistor IGBT4 technology for low saturation losses 	Target Applications	<ul style="list-style-type: none"> Power Regeneration 	Types	<ul style="list-style-type: none"> 30-F206R6A075SB-M443E 30-F206R6A075SB01-M443E10 	<table border="1" style="width:100%; border-collapse: collapse;"> <tr> <th style="background-color: #cccccc;">flow 2 housing</th> </tr> <tr> <td style="text-align: center;">  </td> </tr> <tr> <th style="background-color: #cccccc;">Schematic</th> </tr> <tr> <td style="text-align: center;">  </td> </tr> </table>	flow 2 housing		Schematic	
Features											
<ul style="list-style-type: none"> Inverter, blocking diodes Built-in thermistor IGBT4 technology for low saturation losses 											
Target Applications											
<ul style="list-style-type: none"> Power Regeneration 											
Types											
<ul style="list-style-type: none"> 30-F206R6A075SB-M443E 30-F206R6A075SB01-M443E10 											
flow 2 housing											
											
Schematic											
											

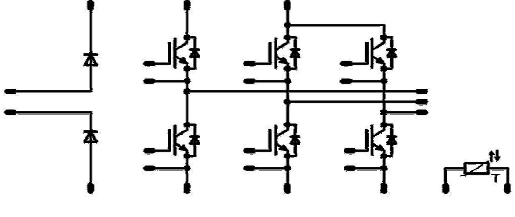
Maximum Ratings

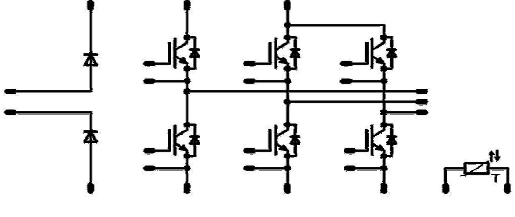
$T_j=25^{\circ}\text{C}$, unless otherwise specified

Parameter	Symbol	Condition	Value	Unit
DC Blocking Diode				
Repetitive peak reverse voltage	V_{RRM}		1600	V
DC forward current	I_{FAV}	$T_j=T_{jmax}$ $T_h=80^{\circ}\text{C}$ $T_c=80^{\circ}\text{C}$	154 208	A
Surge forward current	I_{FSM}	$t_p=10\text{ms}$ $T_j=25^{\circ}\text{C}$	1270	A
I^2t -value	I^2t		2400	A^2s
Power dissipation per Diode	P_{tot}	$T_j=T_{jmax}$ $T_h=80^{\circ}\text{C}$ $T_c=80^{\circ}\text{C}$	189 287	W
Maximum Junction Temperature	T_{jmax}		150	$^{\circ}\text{C}$
Inverter Switch				
Collector-emitter break down voltage	V_{CE}		600	V
DC collector current	I_C	$T_j=T_{jmax}$ $T_h=80^{\circ}\text{C}$ $T_c=80^{\circ}\text{C}$	82 107	A
Pulsed collector current	I_{Cpulse}	t_p limited by T_{jmax}	225	A
Turn off safe operating area		$V_{CE} \leq 1200\text{V}$, $T_j \leq T_{op max}$	225	A
Power dissipation per IGBT	P_{tot}	$T_j=T_{jmax}$ $T_h=80^{\circ}\text{C}$ $T_c=80^{\circ}\text{C}$	160 242	W
Gate-emitter peak voltage	V_{GE}		± 20	V
Short circuit ratings	t_{SC} V_{CC}	$T_j \leq 150^{\circ}\text{C}$ $V_{GE}=15\text{V}$	6 360	μs V
Maximum Junction Temperature	T_{jmax}		175	$^{\circ}\text{C}$

**Maximum Ratings** $T_j=25^{\circ}\text{C}$, unless otherwise specified

Parameter	Symbol	Condition	Value	Unit
-----------	--------	-----------	-------	------

Inverter Diode

Peak Repetitive Reverse Voltage	V_{RRM}		600	V	
DC forward current	I_F	$T_j=T_{jmax}$	$T_h=80^{\circ}\text{C}$	59	A
			$T_c=80^{\circ}\text{C}$	60	
Repetitive peak forward current	I_{FRM}	t_p limited by T_{jmax}	100	A	
Power dissipation per Diode	P_{tot}	$T_j=T_{jmax}$	$T_h=80^{\circ}\text{C}$	94	W
			$T_c=80^{\circ}\text{C}$	143	
Maximum Junction Temperature	T_{jmax}		175	$^{\circ}\text{C}$	

Thermal Properties

Storage temperature	T_{stg}		-40...+kell	$^{\circ}\text{C}$
Operation temperature under switching condition	T_{op}		-40...+($T_{jmax} - 25$)	$^{\circ}\text{C}$

Insulation Properties

Insulation voltage	V_{is}	$t=2\text{s}$ DC voltage	4000	V
Creepage distance			min 12,7	mm
Clearance			min 12,7	mm
Comparative tracking index	CTI		>200	



Characteristic Values

Parameter	Symbol	Conditions					Value			Unit
		$V_{GE}[V]$ or $V_{GS}[V]$	$V_r[V]$ or $V_{CE}[V]$ or $V_{DS}[V]$	$I_c[A]$ or $I_F[A]$ or $I_b[A]$	T_j	Min	Typ	Max		
DC Blocking Diode										
Forward voltage	V_F				100	$T_j=25^\circ C$ $T_j=125^\circ C$	1,12 1,07	1,21		V
Threshold voltage (for power loss calc. only)	V_{to}				100	$T_j=25^\circ C$ $T_j=125^\circ C$	0,89 0,76			V
Slope resistance (for power loss calc. only)	r_t				100	$T_j=25^\circ C$ $T_j=125^\circ C$	2 3			m Ω
Reverse current	I_r			1600		$T_j=25^\circ C$ $T_j=125^\circ C$		0,05		mA
Thermal resistance chip to heatsink per chip	R_{thJH}	Phase-Change Material						0,37		K/W
Thermal resistance chip to heatsink per chip	R_{thJC}							0,24		
Inverter Switch										
Gate emitter threshold voltage	$V_{GE(th)}$	$V_{CE}=V_{GE}$			0,0024	$T_j=25^\circ C$ $T_j=150^\circ C$	5 5,8	6,5		V
Collector-emitter saturation voltage	$V_{CE(sat)}$		15		75	$T_j=25^\circ C$ $T_j=150^\circ C$	1 1,51 1,76	2		V
Collector-emitter cut-off current incl. Diode	I_{CES}		0	600		$T_j=25^\circ C$ $T_j=150^\circ C$		0,005		mA
Gate-emitter leakage current	I_{GES}		20	0		$T_j=25^\circ C$ $T_j=150^\circ C$		600		nA
Integrated Gate resistor	R_{gint}							none		Ω
Turn-on delay time	$t_{d(on)}$	$R_{goff}=4 \Omega$ $R_{gon}=4 \Omega$	± 15	300	75	$T_j=25^\circ C$ $T_j=150^\circ C$	90 91		ns	
Rise time	t_r					$T_j=25^\circ C$ $T_j=150^\circ C$	17 19			
Turn-off delay time	$t_{d(off)}$					$T_j=25^\circ C$ $T_j=150^\circ C$	143 167			
Fall time	t_f					$T_j=25^\circ C$ $T_j=150^\circ C$	54 80			
Turn-on energy loss per pulse	E_{on}					$T_j=25^\circ C$ $T_j=150^\circ C$	0,52 0,84	mWs		
Turn-off energy loss per pulse	E_{off}	$T_j=25^\circ C$ $T_j=150^\circ C$	1,54 2,25							
Input capacitance	C_{ies}						4620		pF	
Output capacitance	C_{oss}	$f=1MHz$	0	25		$T_j=25^\circ C$	288			
Reverse transfer capacitance	C_{riss}						137			
Gate charge	Q_{Gate}		± 15	480	75	$T_j=25^\circ C$		470		nC
Thermal resistance chip to heatsink per chip	R_{thJH}	Phase-Change Material						0,59		K/W
Thermal resistance chip to case per chip	R_{thJC}							0,39		
Inverter Diode										
Diode forward voltage	V_F				50	$T_j=25^\circ C$ $T_j=150^\circ C$	1,1 1,63 1,52	2,2		V
Peak reverse recovery current	I_{RRM}	$R_{gon}=4 \Omega$	± 15	300	75	$T_j=25^\circ C$ $T_j=150^\circ C$	65 79		A	
Reverse recovery time	t_{rr}					$T_j=25^\circ C$ $T_j=150^\circ C$	109 141			
Reverse recovered charge	Q_{rr}					$T_j=25^\circ C$ $T_j=150^\circ C$	2,73 6,02	μC		
Peak rate of fall of recovery current	$di(rec)max/dt$					$T_j=25^\circ C$ $T_j=150^\circ C$	5301 2434	A/ μs		
Reverse recovered energy	E_{rec}					$T_j=25^\circ C$ $T_j=150^\circ C$	0,66 1,5	mWs		
Thermal resistance chip to heatsink per chip	R_{thJH}	Phase-Change Material						1,01		K/W
Thermal resistance chip to case per chip	R_{thJC}							0,67		
Thermistor										
Rated resistance	R					$T_j=25^\circ C$		22000		Ω
Deviation of R100	$\Delta R/R$	R100=1486 Ω				T=100 $^\circ C$	-12	14		%
Power dissipation	P					Tc=100 $^\circ C$		200		mW
Power dissipation constant						$T_j=25^\circ C$		2		mW/K
B-value	$B_{(25/50)}$	Tol. $\pm 3\%$				$T_j=25^\circ C$		3950		K
B-value	$B_{(25/100)}$	Tol. $\pm 3\%$				$T_j=25^\circ C$		3998		K
Vincotech NTC Reference						$T_j=25^\circ C$			B	



T1,T2,T3,T4,T5,T6/D1,D2,D3,D4,D5,D6

Figure 1 T1,T2,T3,T4,T5,T6 IGBT

Typical output characteristics

$I_C = f(V_{CE})$

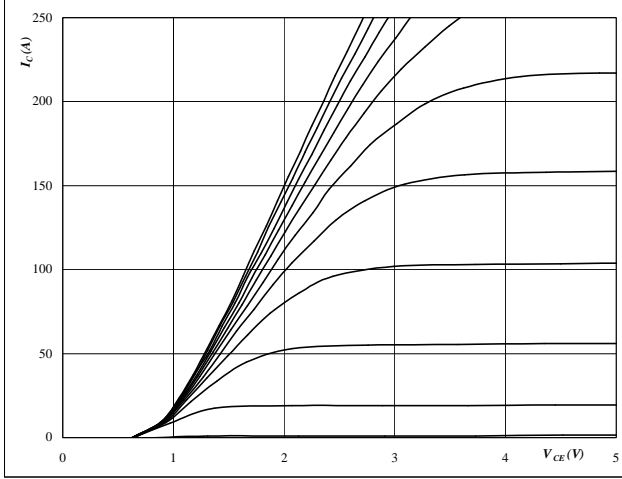

At
 $t_p = 250 \mu s$
 $T_j = 25 \text{ } ^\circ C$
 V_{GE} from 7 V to 17 V in steps of 1 V

Figure 2 T1,T2,T3,T4,T5,T6 IGBT

Typical output characteristics

$I_C = f(V_{CE})$

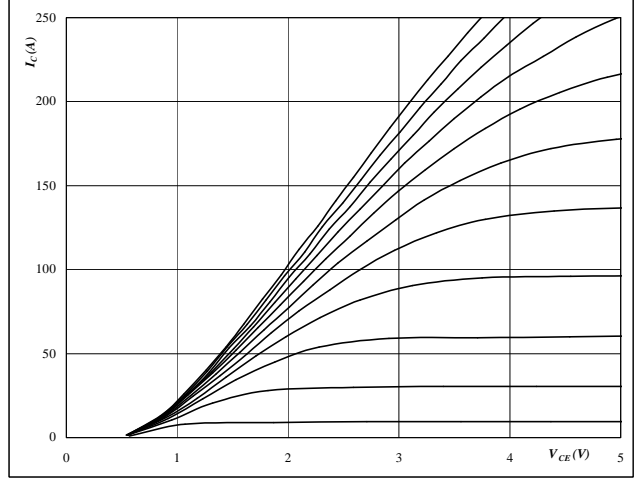

At
 $t_p = 250 \mu s$
 $T_j = 150 \text{ } ^\circ C$
 V_{GE} from 7 V to 17 V in steps of 1 V

Figure 3 T1,T2,T3,T4,T5,T6 IGBT

Typical transfer characteristics

$I_C = f(V_{GE})$

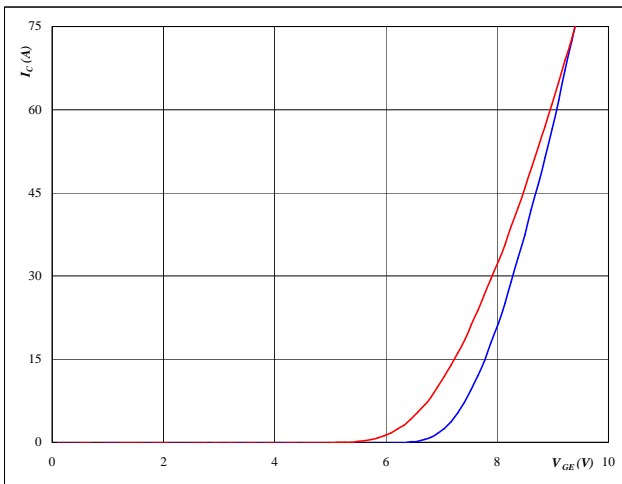

At
 $T_j = 25/150 \text{ } ^\circ C$
 $t_p = 250 \mu s$
 $V_{CE} = 10 \text{ V}$

Figure 4 D1,D2,D3,D4,D5,D6 FWD

Typical diode forward current as a function of forward voltage

$I_F = f(V_F)$

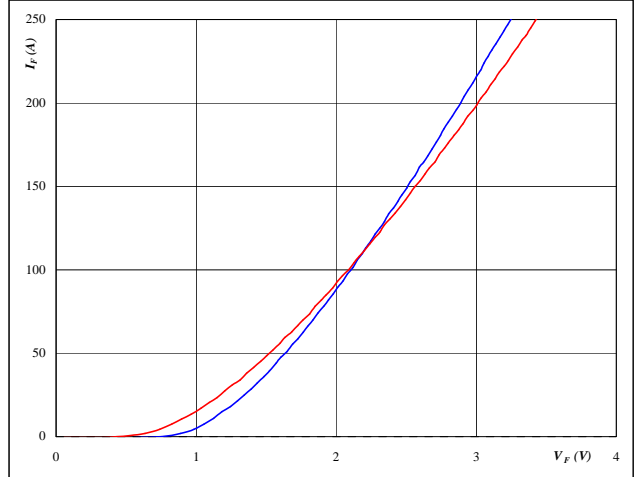

At
 $T_j = 25/150 \text{ } ^\circ C$
 $t_p = 250 \mu s$



T1,T2,T3,T4,T5,T6/D1,D2,D3,D4,D5,D6

Figure 5 T1,T2,T3,T4,T5,T6 IGBT

Typical switching energy losses
as a function of collector current

$E = f(I_C)$

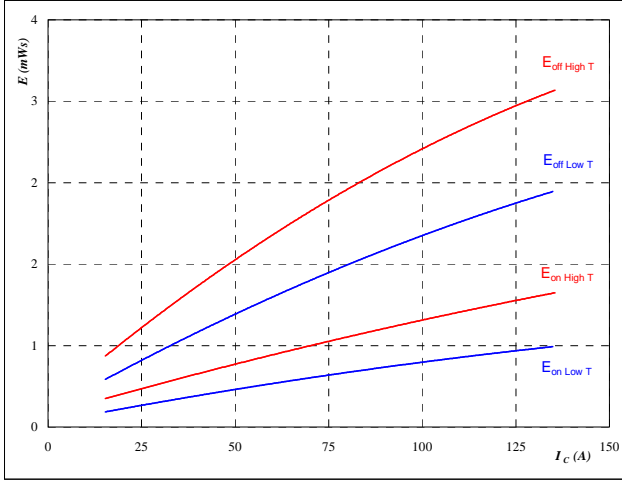

With an inductive load at

- $T_J = 25/150 \text{ } ^\circ\text{C}$
- $V_{CE} = 300 \text{ V}$
- $V_{GE} = \pm 15 \text{ V}$
- $R_{gon} = 4 \text{ } \Omega$
- $R_{goff} = 4 \text{ } \Omega$

Figure 6 T1,T2,T3,T4,T5,T6 IGBT

Typical switching energy losses
as a function of gate resistor

$E = f(R_G)$

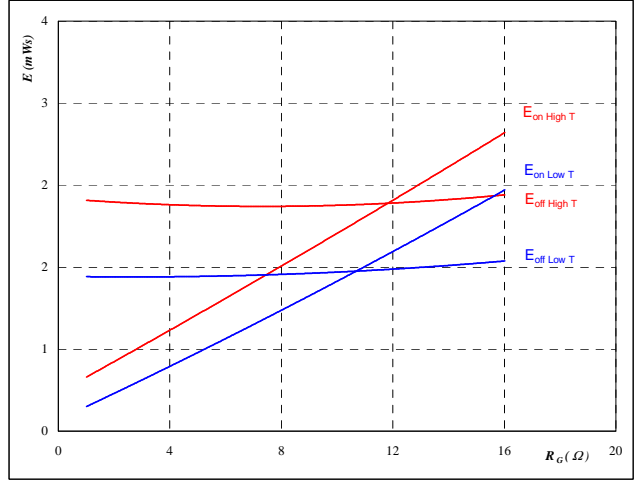

With an inductive load at

- $T_J = 25/150 \text{ } ^\circ\text{C}$
- $V_{CE} = 300 \text{ V}$
- $V_{GE} = \pm 15 \text{ V}$
- $I_C = 75 \text{ A}$

Figure 7 D1,D2,D3,D4,D5,D6 FWD

Typical reverse recovery energy loss
as a function of collector current

$E_{rec} = f(I_C)$

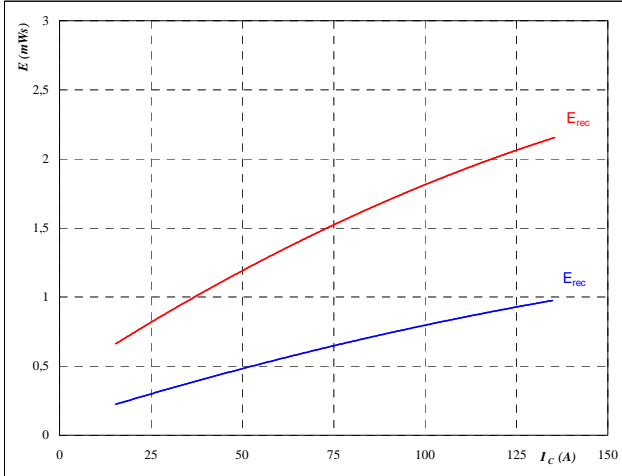

With an inductive load at

- $T_J = 25/150 \text{ } ^\circ\text{C}$
- $V_{CE} = 300 \text{ V}$
- $V_{GE} = \pm 15 \text{ V}$
- $R_{gon} = 4 \text{ } \Omega$

Figure 8 D1,D2,D3,D4,D5,D6 FWD

Typical reverse recovery energy loss
as a function of gate resistor

$E_{rec} = f(R_G)$

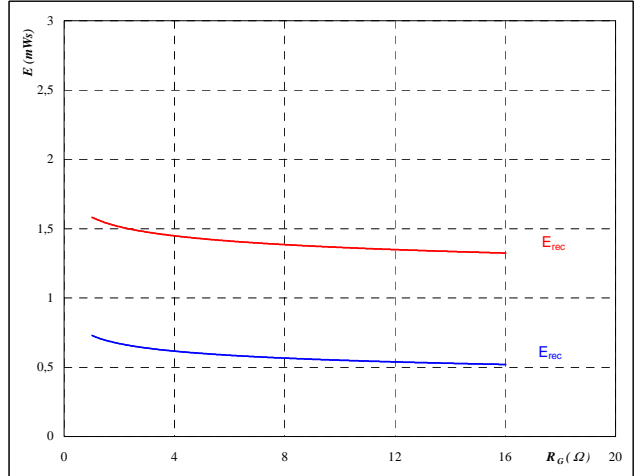

With an inductive load at

- $T_J = 25/150 \text{ } ^\circ\text{C}$
- $V_{CE} = 300 \text{ V}$
- $V_{GE} = \pm 15 \text{ V}$
- $I_C = 75 \text{ A}$



T1,T2,T3,T4,T5,T6/D1,D2,D3,D4,D5,D6

Figure 9 T1,T2,T3,T4,T5,T6 IGBT

Typical switching times as a function of collector current

$t = f(I_C)$

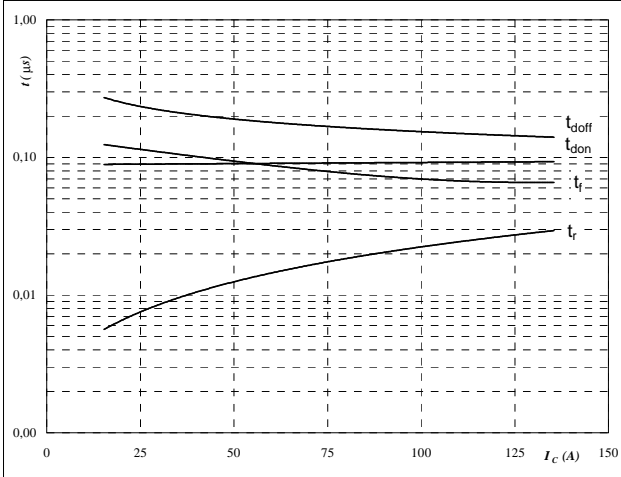

With an inductive load at

- $T_j = 150$ °C
- $V_{CE} = 300$ V
- $V_{GE} = \pm 15$ V
- $R_{gon} = 4$ Ω
- $R_{goff} = 4$ Ω

Figure 10 T1,T2,T3,T4,T5,T6 IGBT

Typical switching times as a function of gate resistor

$t = f(R_G)$

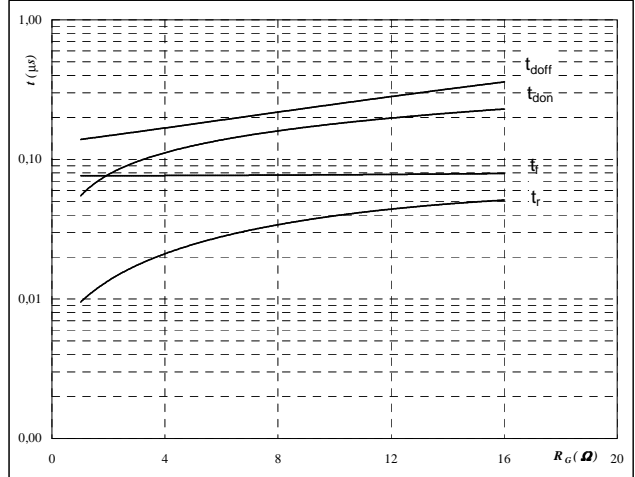

With an inductive load at

- $T_j = 150$ °C
- $V_{CE} = 300$ V
- $V_{GE} = \pm 15$ V
- $I_C = 75$ A

Figure 11 D1,D2,D3,D4,D5,D6 FWD

Typical reverse recovery time as a function of collector current

$t_{rr} = f(I_C)$

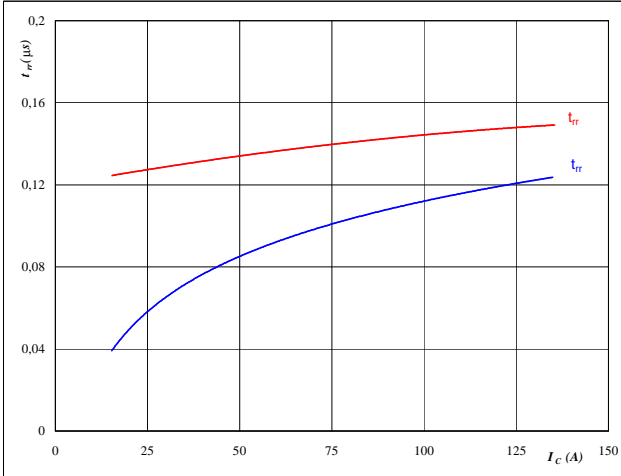

At

- $T_j = 25/150$ °C
- $V_{CE} = 300$ V
- $V_{GE} = \pm 15$ V
- $R_{gon} = 4$ Ω

Figure 12 D1,D2,D3,D4,D5,D6 FWD

Typical reverse recovery time as a function of IGBT turn on gate resistor

$t_{rr} = f(R_{gon})$

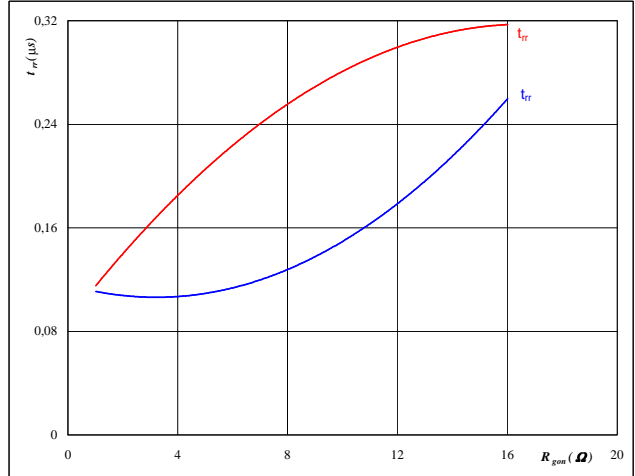

At

- $T_j = 25/150$ °C
- $V_R = 300$ V
- $I_F = 75$ A
- $V_{GE} = \pm 15$ V



T1,T2,T3,T4,T5,T6/D1,D2,D3,D4,D5,D6

Figure 13 D1,D2,D3,D4,D5,D6 FWD

Typical reverse recovery charge as a function of collector current

$Q_{rr} = f(I_C)$

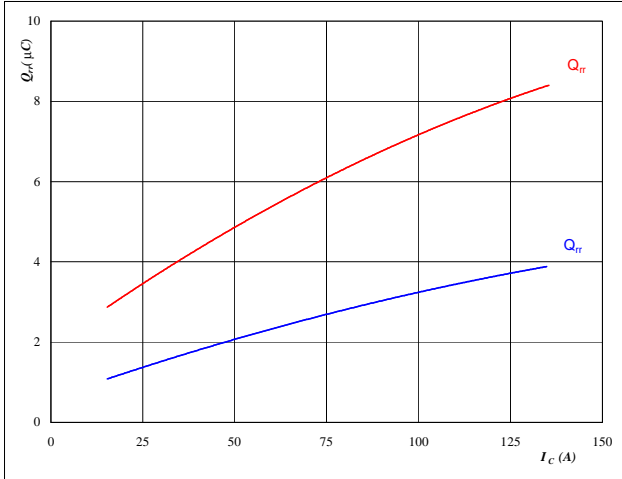

At

- $T_j = 25/150$ °C
- $V_{CE} = 300$ V
- $V_{GE} = \pm 15$ V
- $R_{gon} = 4$ Ω

Figure 14 D1,D2,D3,D4,D5,D6 FWD

Typical reverse recovery charge as a function of IGBT turn on gate resistor

$Q_{rr} = f(R_{gon})$

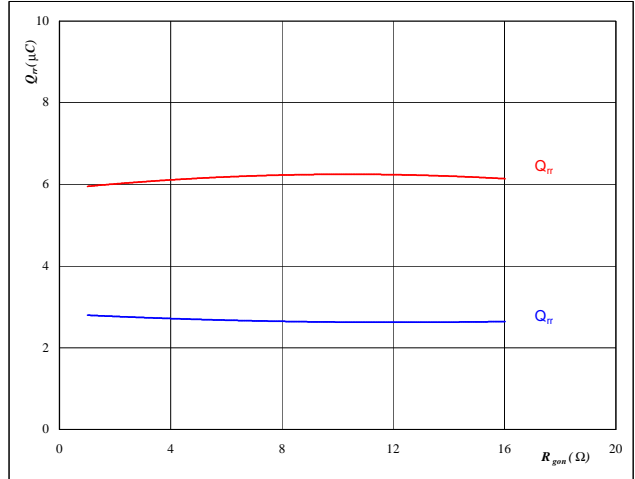

At

- $T_j = 25/150$ °C
- $V_R = 300$ V
- $I_F = 75$ A
- $V_{GE} = \pm 15$ V

Figure 15 D1,D2,D3,D4,D5,D6 FWD

Typical reverse recovery current as a function of collector current

$I_{RRM} = f(I_C)$

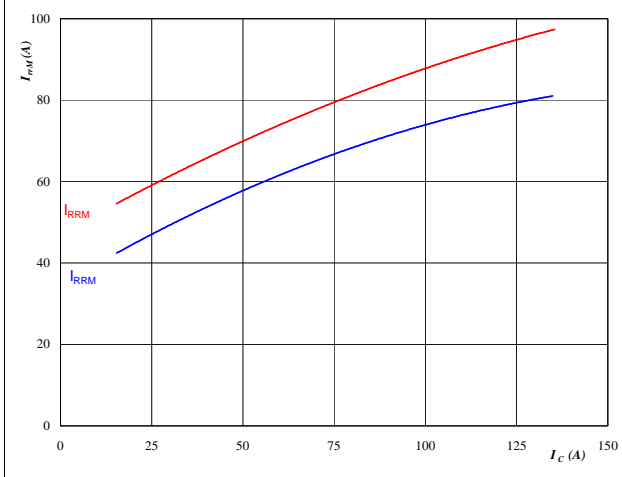

At

- $T_j = 25/150$ °C
- $V_{CE} = 300$ V
- $V_{GE} = \pm 15$ V
- $R_{gon} = 4$ Ω

Figure 16 D1,D2,D3,D4,D5,D6 FWD

Typical reverse recovery current as a function of IGBT turn on gate resistor

$I_{RRM} = f(R_{gon})$

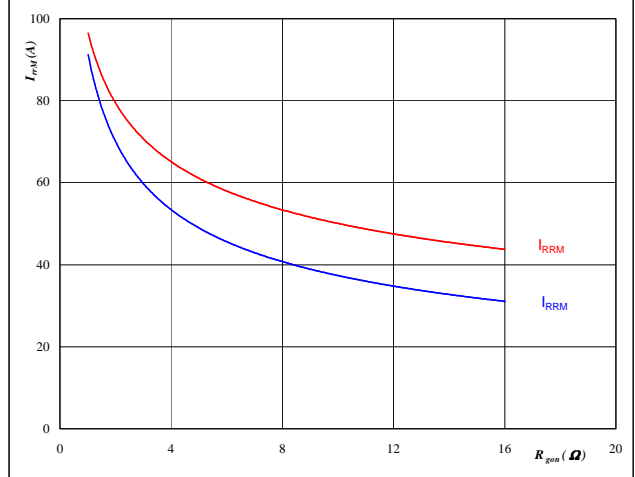

At

- $T_j = 25/150$ °C
- $V_R = 300$ V
- $I_F = 75$ A
- $V_{GE} = \pm 15$ V



T1,T2,T3,T4,T5,T6/D1,D2,D3,D4,D5,D6

Figure 17 D1,D2,D3,D4,D5,D6 FWD

Typical rate of fall of forward and reverse recovery current as a function of collector current

$dI_f/dt, dI_{rec}/dt = f(I_C)$

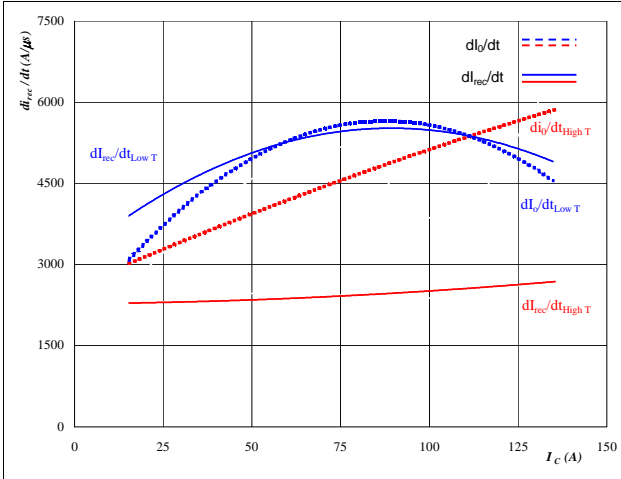

At
 $T_j = 25/150 \text{ } ^\circ\text{C}$
 $V_{CE} = 300 \text{ V}$
 $V_{GE} = \pm 15 \text{ V}$
 $R_{gon} = 4 \text{ } \Omega$

Figure 18 D1,D2,D3,D4,D5,D6 FWD

Typical rate of fall of forward and reverse recovery current as a function of IGBT turn on gate resistor

$dI_f/dt, dI_{rec}/dt = f(R_{gon})$

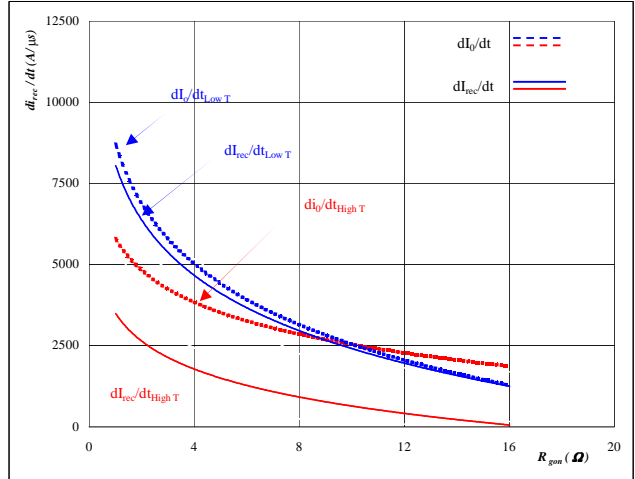

At
 $T_j = 25/150 \text{ } ^\circ\text{C}$
 $V_R = 300 \text{ V}$
 $I_F = 75 \text{ A}$
 $V_{GE} = \pm 15 \text{ V}$

Figure 19 T1,T2,T3,T4,T5,T6 IGBT

IGBT transient thermal impedance as a function of pulse width

$Z_{thJH} = f(t_p)$

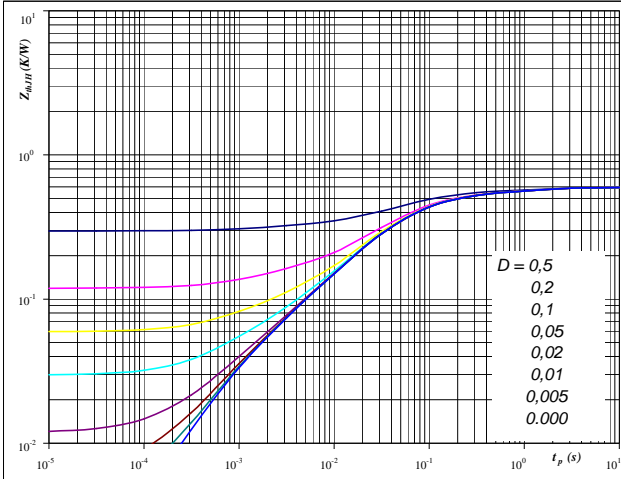

At
 $D = t_p / T$
 $R_{thJH} = 0,59 \text{ K/W}$

IGBT thermal model values

Phase-Change Material	
R (C/W)	Tau (s)
0,07	1,2E+00
0,15	1,3E-01
0,26	3,8E-02
0,07	1,0E-02
0,03	1,1E-03

Figure 20 D1,D2,D3,D4,D5,D6 FWD

FWD transient thermal impedance as a function of pulse width

$Z_{thJH} = f(t_p)$

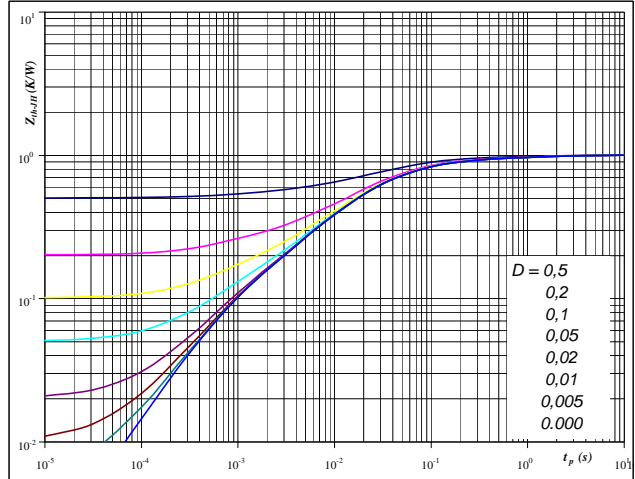

At
 $D = t_p / T$
 $R_{thJH} = 1,01 \text{ K/W}$

FWD thermal model values

Phase-Change Material	
R (C/W)	Tau (s)
0,04	3,5E+00
0,08	4,7E-01
0,28	7,2E-02
0,41	2,0E-02
0,13	5,0E-03
0,07	6,9E-04



T1,T2,T3,T4,T5,T6/D1,D2,D3,D4,D5,D6

Figure 21 T1,T2,T3,T4,T5,T6 IGBT

Power dissipation as a function of heatsink temperature

$P_{tot} = f(T_h)$

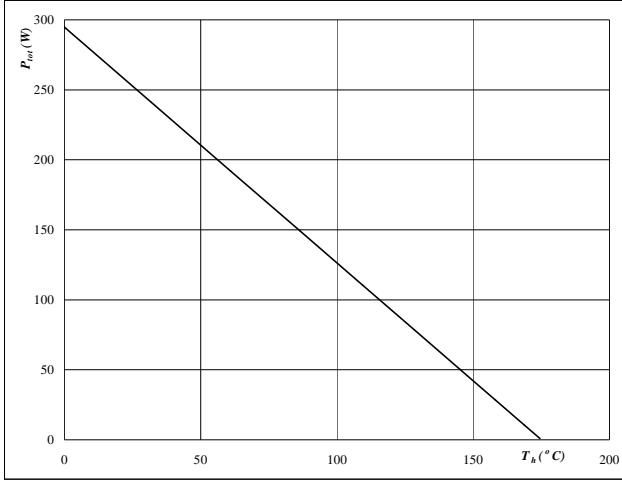

At
 $T_j = 175 \text{ } ^\circ\text{C}$

Figure 22 T1,T2,T3,T4,T5,T6 IGBT

Collector current as a function of heatsink temperature

$I_C = f(T_h)$

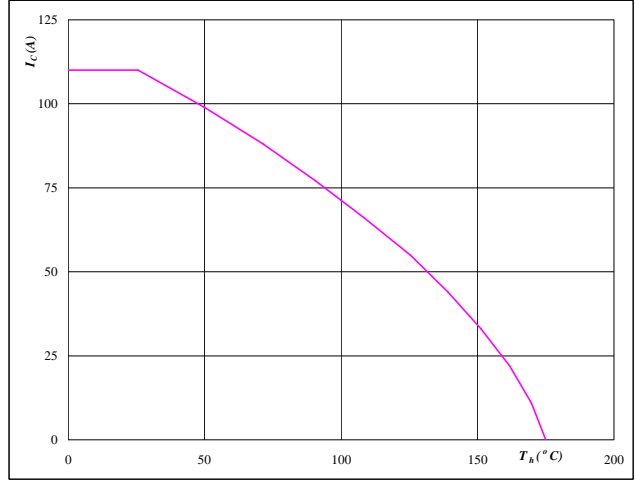

At
 $T_j = 175 \text{ } ^\circ\text{C}$
 $V_{GE} = 15 \text{ V}$

Figure 23 D1,D2,D3,D4,D5,D6 FWD

Power dissipation as a function of heatsink temperature

$P_{tot} = f(T_h)$

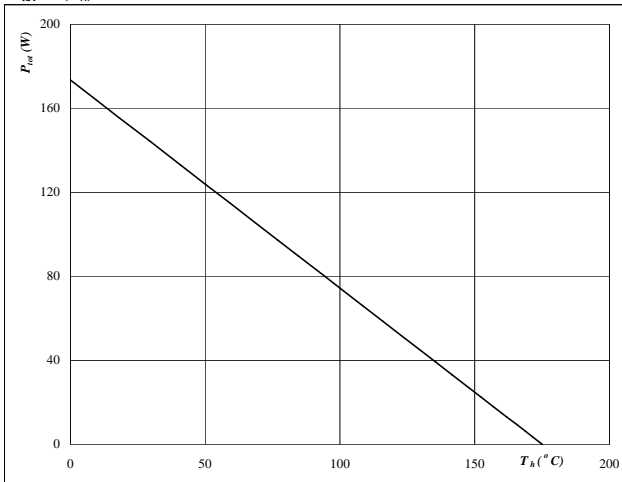

At
 $T_j = 175 \text{ } ^\circ\text{C}$

Figure 24 D1,D2,D3,D4,D5,D6 FWD

Forward current as a function of heatsink temperature

$I_F = f(T_h)$

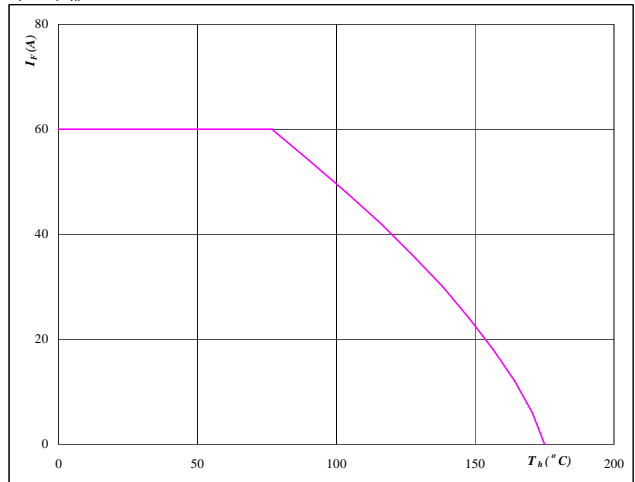

At
 $T_j = 175 \text{ } ^\circ\text{C}$



T1,T2,T3,T4,T5,T6/D1,D2,D3,D4,D5,D6

Figure 25 T1,T2,T3,T4,T5,T6 IGBT

Safe operating area as a function of collector-emitter voltage
 $I_C = f(V_{CE})$

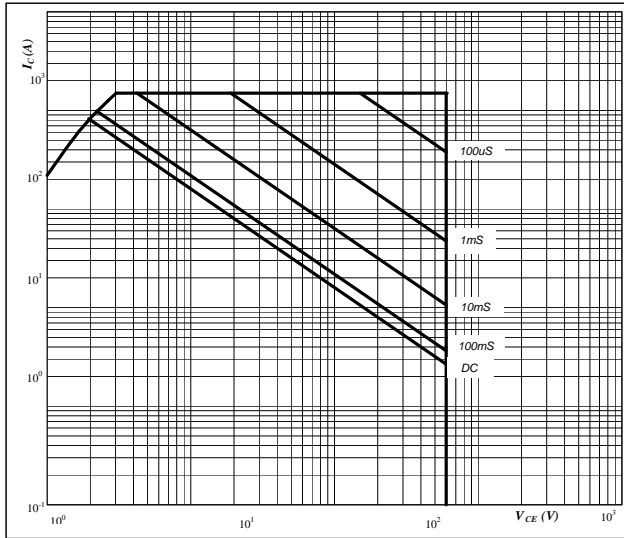

At
 D = single pulse
 $T_h = 80$ °C
 $V_{GE} = \pm 15$ V
 $T_j = T_{jmax}$ °C

Figure 26 T1,T2,T3,T4,T5,T6 IGBT

Gate voltage vs Gate charge

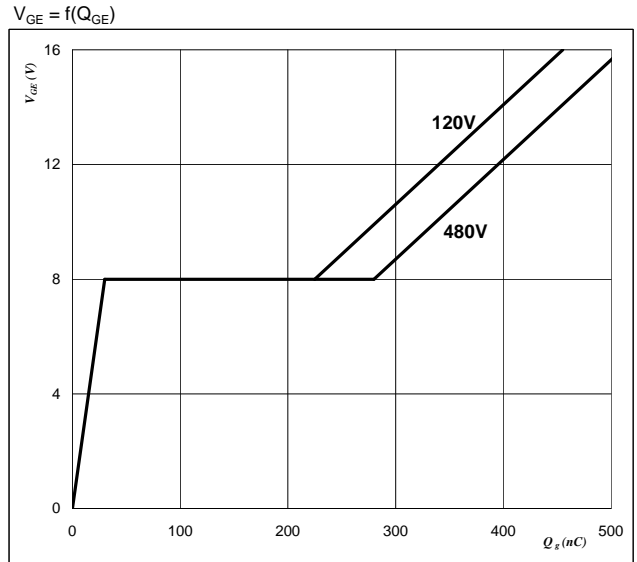

At
 $I_C = 75$ A

Figure 27 T1,T2,T3,T4,T5,T6 IGBT

Short circuit withstand time as a function of gate-emitter voltage
 $t_{sc} = f(V_{GE})$

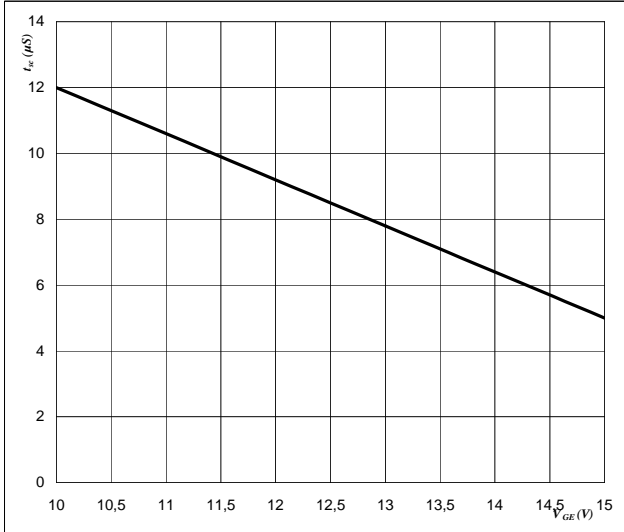

At
 $V_{CE} = 600$ V
 $T_j \leq 175$ °C

Figure 28 T1,T2,T3,T4,T5,T6 IGBT

Typical short circuit collector current as a function of gate-emitter voltage
 $V_{GE} = f(Q_{GE})$

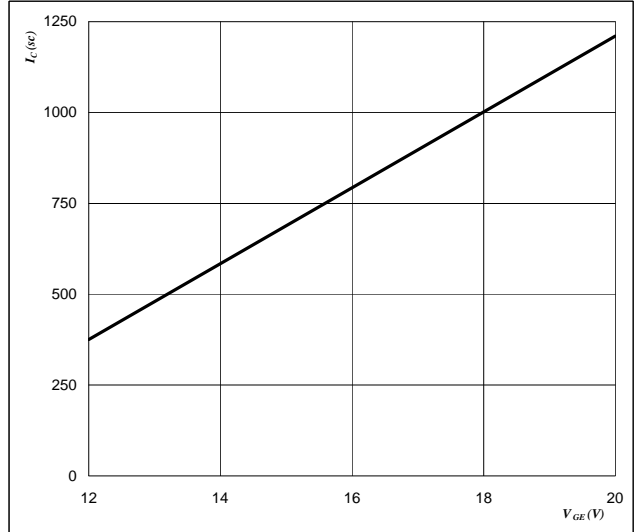

At
 $V_{CE} \leq 600$ V
 $T_j = 175$ °C



Vincotech

Figure 29 T1,T2,T3,T4,T5,T6 IGBT

Reverse bias safe operating area

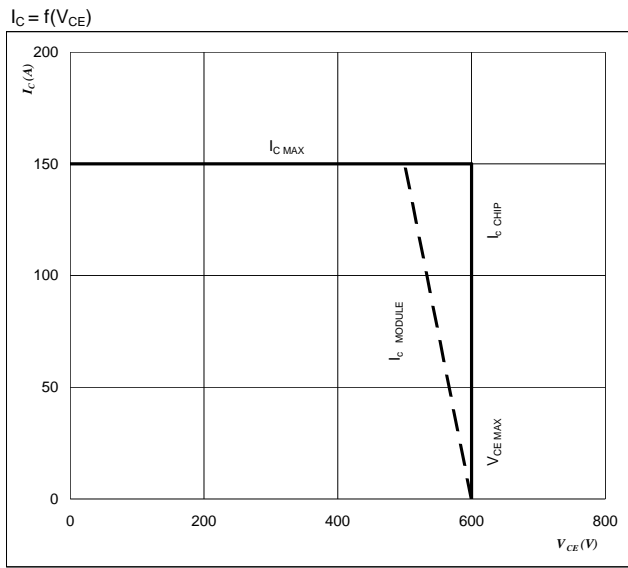

At
 $T_j = 150\ ^\circ\text{C}$
 $R_{gon} = 4\ \Omega$
 $R_{goff} = 4\ \Omega$



D7a-b,D8a-b

Figure 1 D7a-b,D8a-b

Typical diode forward current as a function of forward voltage

$I_F = f(V_F)$

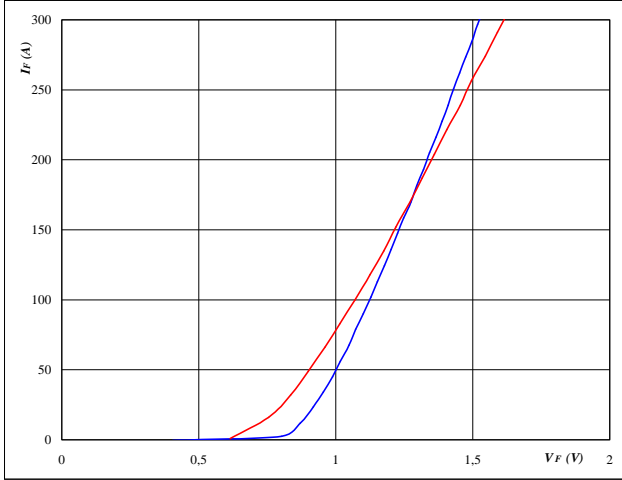

At
 $T_j = 25/125 \text{ } ^\circ\text{C}$
 $t_p = 250 \text{ } \mu\text{s}$

Figure 2 D7a-b,D8a-b

Diode transient thermal impedance as a function of pulse width

$Z_{thJH} = f(t_p)$

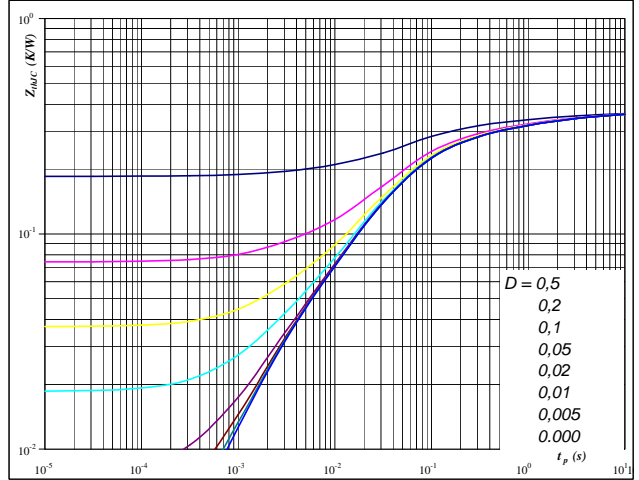

At
 $D = t_p / T$
 $R_{thJH} = 0,37 \text{ K/W}$

Figure 3 D7a-b,D8a-b

Power dissipation as a function of heatsink temperature

$P_{tot} = f(T_h)$

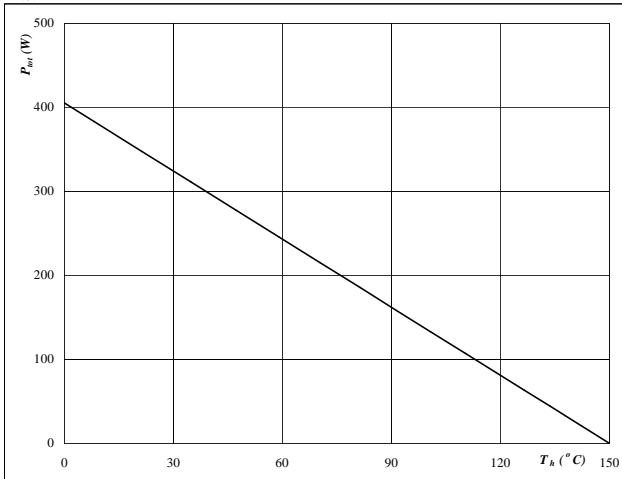

At
 $T_j = 150 \text{ } ^\circ\text{C}$

Figure 4 D7a-b,D8a-b

Forward current as a function of heatsink temperature

$I_F = f(T_h)$

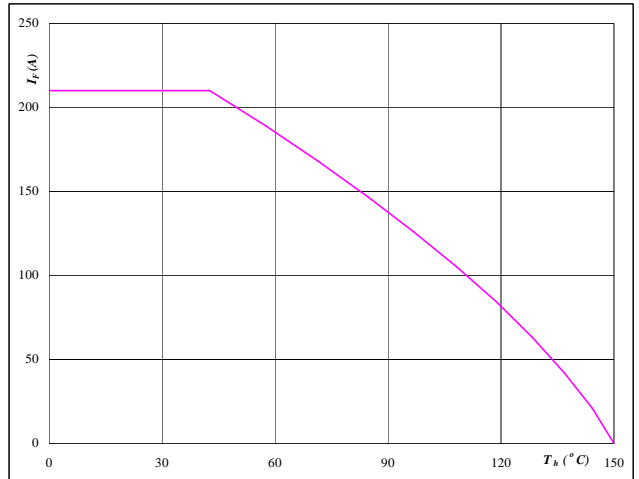

At
 $T_j = 150 \text{ } ^\circ\text{C}$



Thermistor

Figure 1 Thermistor

Typical NTC characteristic
as a function of temperature

$$R_T = f(T)$$

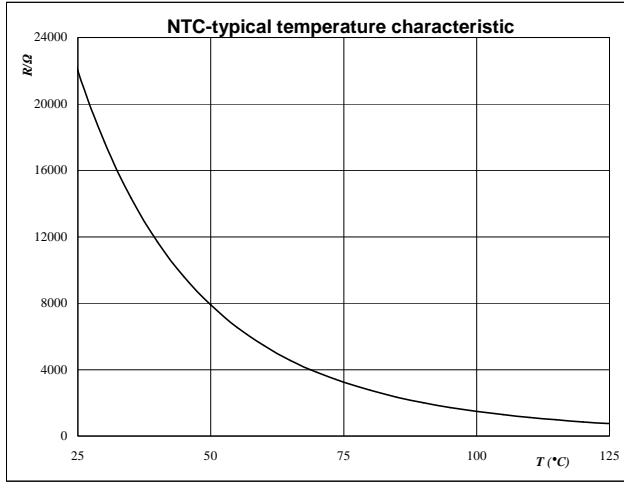



Switching Definitions Output Inverter

General conditions	
T_j	= 150 °C
R_{gon}	= 4 Ω
R_{goff}	= 4 Ω

Figure 1 T1,T2,T3,T4,T5,T6 IGBT

Turn-off Switching Waveforms & definition of t_{doff} , t_{Eoff}
 (t_{Eoff} = integrating time for E_{off})

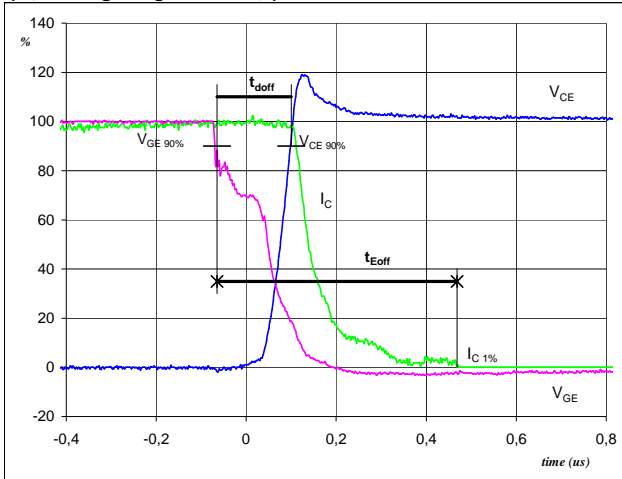

$V_{GE}(0\%) =$	-15	V
$V_{GE}(100\%) =$	15	V
$V_C(100\%) =$	300	V
$I_C(100\%) =$	75	A
$t_{doff} =$	0,17	μs
$t_{Eoff} =$	0,53	μs

Figure 2 T1,T2,T3,T4,T5,T6 IGBT

Turn-on Switching Waveforms & definition of t_{don} , t_{Eon}
 (t_{Eon} = integrating time for E_{on})

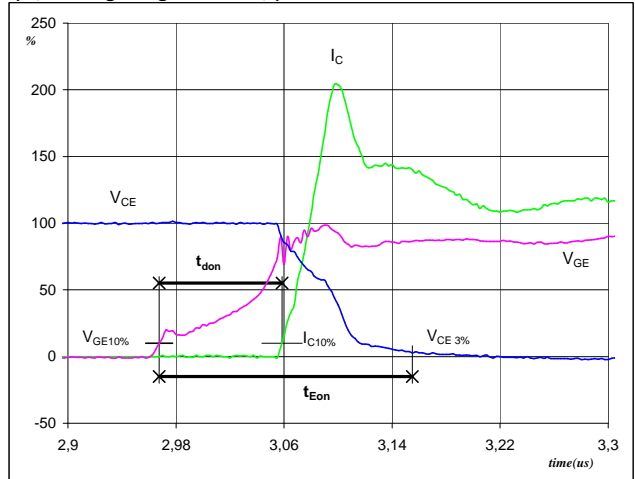

$V_{GE}(0\%) =$	-15	V
$V_{GE}(100\%) =$	15	V
$V_C(100\%) =$	300	V
$I_C(100\%) =$	75	A
$t_{don} =$	0,09	μs
$t_{Eon} =$	0,19	μs

Figure 3 T1,T2,T3,T4,T5,T6 IGBT

Turn-off Switching Waveforms & definition of t_f

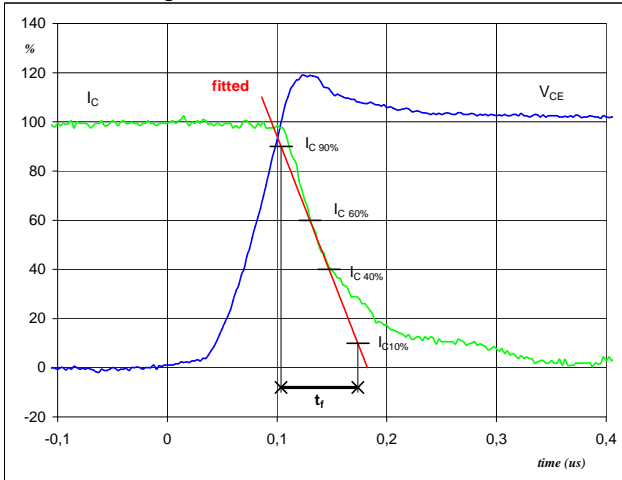

$V_C(100\%) =$	300	V
$I_C(100\%) =$	75	A
$t_f =$	0,08	μs

Figure 4 T1,T2,T3,T4,T5,T6 IGBT

Turn-on Switching Waveforms & definition of t_r

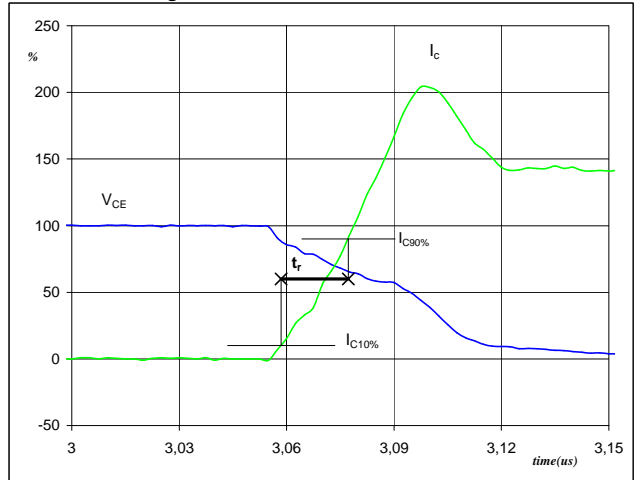

$V_C(100\%) =$	300	V
$I_C(100\%) =$	75	A
$t_r =$	0,02	μs



Switching Definitions Output Inverter

Figure 5 T1,T2,T3,T4,T5,T6 IGBT

Turn-off Switching Waveforms & definition of t_{Eoff}

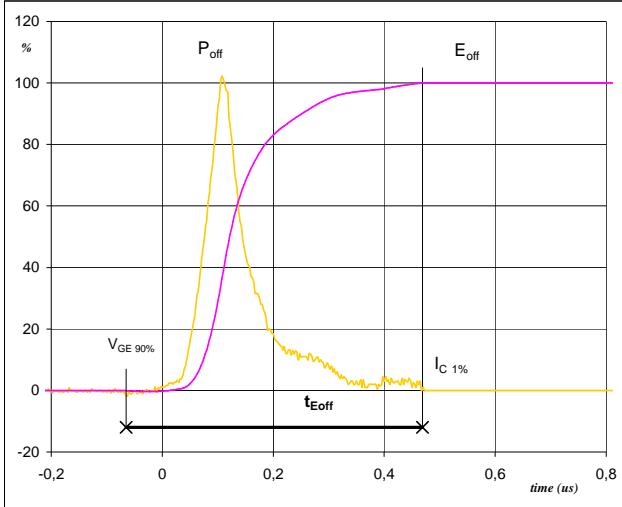

$P_{off}(100\%) = 22,37 \text{ kW}$
 $E_{off}(100\%) = 2,25 \text{ mJ}$
 $t_{Eoff} = 0,53 \text{ }\mu\text{s}$

Figure 6 T1,T2,T3,T4,T5,T6 IGBT

Turn-on Switching Waveforms & definition of t_{Eon}

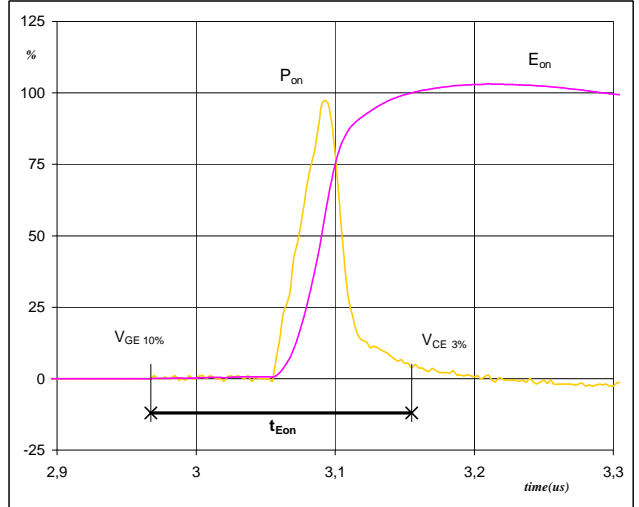

$P_{on}(100\%) = 22,37 \text{ kW}$
 $E_{on}(100\%) = 0,84 \text{ mJ}$
 $t_{Eon} = 0,19 \text{ }\mu\text{s}$

Figure 7 D1,D2,D3,D4,D5,D6 FWD

Turn-off Switching Waveforms & definition of t_{rr}

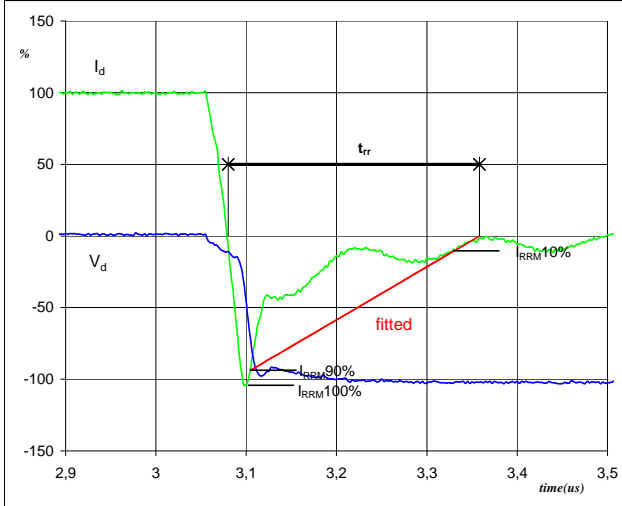

$V_d(100\%) = 300 \text{ V}$
 $I_d(100\%) = 75 \text{ A}$
 $I_{RRM}(100\%) = -79 \text{ A}$
 $t_{rr} = 0,14 \text{ }\mu\text{s}$



Switching Definitions Output Inverter

Figure 8 D1,D2,D3,D4,D5,D6 FWD

Turn-on Switching Waveforms & definition of t_{Qrr}
 (t_{Qrr} = integrating time for Q_{rr})

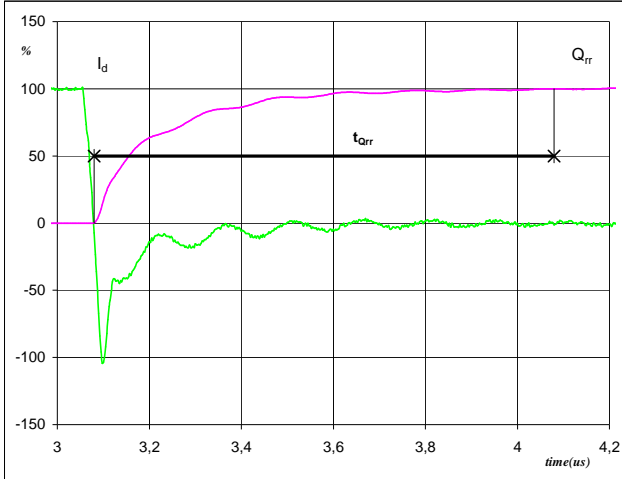

I_d (100%) =	75	A
Q_{rr} (100%) =	6,02	μC
t_{Qrr} =	1,00	μs

Figure 9 D1,D2,D3,D4,D5,D6 FWD

Turn-on Switching Waveforms & definition of t_{Erec}
 (t_{Erec} = integrating time for E_{rec})

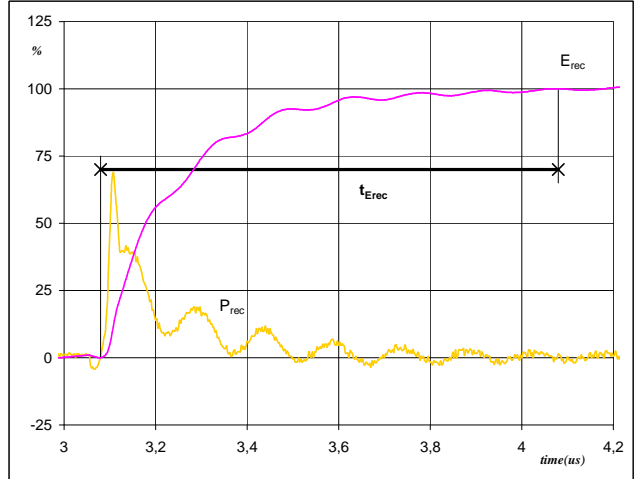

P_{rec} (100%) =	22,37	kW
E_{rec} (100%) =	1,50	mJ
t_{Erec} =	1,00	μs



Ordering Code and Marking - Outline - Pinout

Ordering Code & Marking			
Version	Ordering Code	in DataMatrix as	in packaging barcode as
17mm housing	30-F206R6A075SB-M443E	M443-E	M443-E
17mm housing, without thermistor	30-F206R6A075SB01-M443E10	M443-E10	M443-E10

Outline

Pin table			Pin table		
Pin	X	Y	Pin	X	Y
1	712	0	29	0	372
2	68,7	0	30	2,5	372
3	66,2	0	31	5	372
4	63,7	0	32	7,8	372
5	55,95	0	33	10,6	372
6	53,45	0	34	18,45	372
7	55,95	2,8	35	2125	372
8	53,45	2,8	36	24,05	372
9	48,4	0	37	26,55	372
10	45,9	0	38	29,05	372
11	38,9	0	39	36,1	372
12	36,1	0	40	38,6	372
13	38,9	2,8	41	41,1	372
14	36,1	2,8	42	43,9	372
15	31,3	0	43	46,7	372
16	28,5	0	44	53,7	372
17	31,3	2,8	45	56,2	372
18	28,5	2,8	46	58,7	372
19	19,3	0	47	71,2	372
20	19,3	2,8	48	71,2	34,7
21	12,3	0	49	71,2	25,2
22	9,8	0	50	71,2	22,7
23	12,3	2,8	51	71,2	20,2
24	9,8	2,8	52	71,2	12,8
25	2,8	0	53	68,7	12,8
26	0	0			
27	2,8	2,8			
28	0	2,8			

Tolerance of pinpositions: ±0.05mm at the end of pins
Dimension of coordinate axis is only offset without tolerance

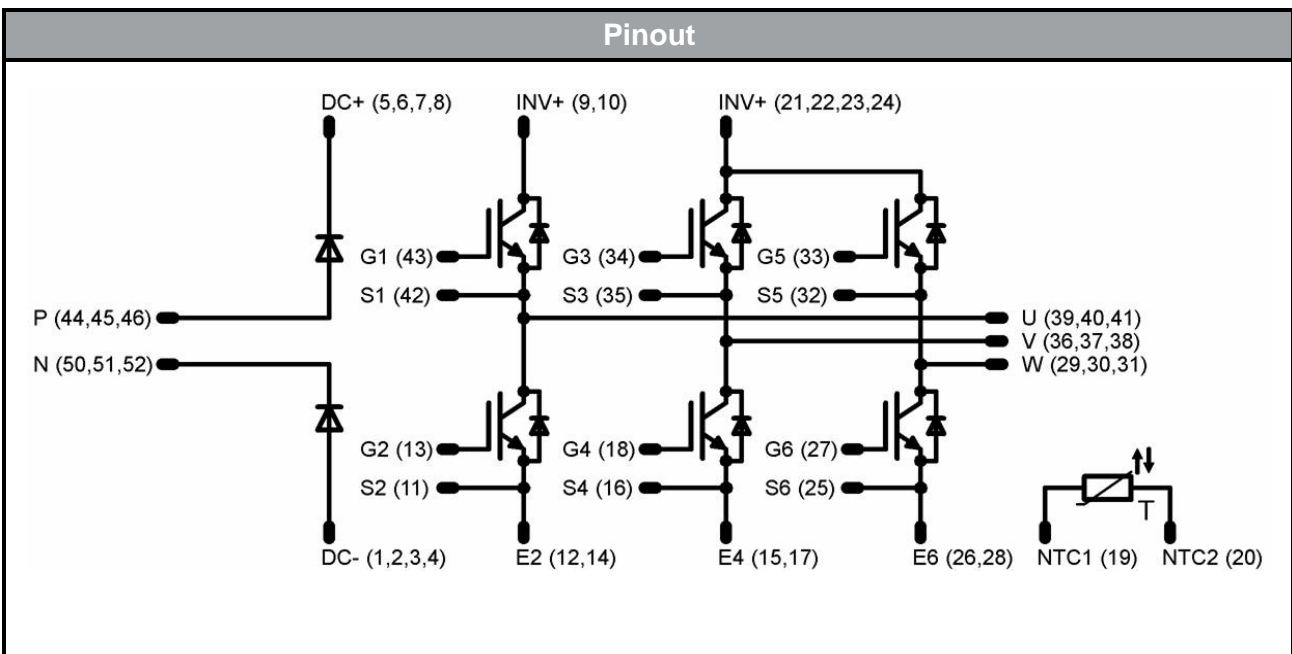



DISCLAIMER

The information given in this datasheet describes the type of component and does not represent assured characteristics. For tested values please contact Vincotech. Vincotech reserves the right to make changes without further notice to any products herein to improve reliability, function or design. Vincotech does not assume any liability arising out of the application or use of any product or circuit described herein; neither does it convey any license under its patent rights, nor the rights of others.

LIFE SUPPORT POLICY

Vincotech products are not authorised for use as critical components in life support devices or systems without the express written approval of Vincotech.

As used herein:

1. Life support devices or systems are devices or systems which, (a) are intended for surgical implant into the body, or (b) support or sustain life, or (c) whose failure to perform when properly used in accordance with instructions for use provided in labelling can be reasonably expected to result in significant injury to the user.
2. A critical component is any component of a life support device or system whose failure to perform can be reasonably expected to cause the failure of the life support device or system, or to affect its safety or effectiveness.