







Vincotech

**10-FY12PMA025M7-P588A78**  
**10-PY12PMA025M7-P588A78Y**  
**10-F112PMA025M7-P588A79**  
**10-P112PMA025M7-P588A79Y**  
 datasheet

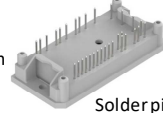
<i>flow PIM 1</i>	1200 V / 25 A
<div style="background-color: #eee; padding: 2px; text-align: center; font-weight: bold; margin-bottom: 5px;">Features</div> <ul style="list-style-type: none"> <li>IGBT M7 with low <math>V_{CEsat}</math> and improved EMC behavior</li> <li>Open emitter configuration</li> <li>Compact and low inductive design</li> <li>Built-in NTC</li> </ul>	<div style="background-color: #eee; padding: 2px; text-align: center; font-weight: bold; margin-bottom: 5px;">flow 1 housing</div> <div style="display: flex; justify-content: space-around;"> <div style="text-align: center;"> <p>12 mm</p>  </div> <div style="text-align: center;">  </div> </div> <div style="display: flex; justify-content: space-around; margin-top: 10px;"> <div style="text-align: center;"> <p>17 mm</p>  <p>Solder pins</p> </div> <div style="text-align: center;">  <p>Press-fit pins</p> </div> </div>
<div style="background-color: #eee; padding: 2px; text-align: center; font-weight: bold; margin-bottom: 5px;">Target applications</div> <ul style="list-style-type: none"> <li>Industrial Drives</li> </ul>	<div style="background-color: #eee; padding: 2px; text-align: center; font-weight: bold; margin-bottom: 5px;">Schematic</div> 
<div style="background-color: #eee; padding: 2px; text-align: center; font-weight: bold; margin-bottom: 5px;">Types</div> <ul style="list-style-type: none"> <li>10-FY12PMA025M7-P588A78</li> <li>10-PY12PMA025M7-P588A78Y</li> <li>10-F112PMA025M7-P588A79</li> <li>10-P112PMA025M7-P588A79Y</li> </ul>	

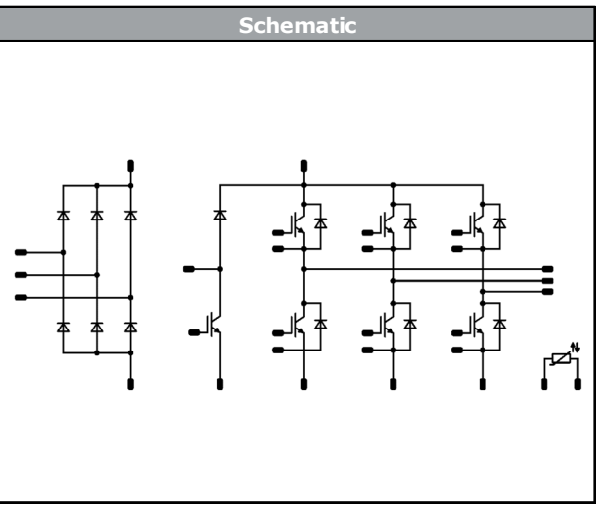
## Maximum Ratings

$T_j = 25\text{ °C}$ , unless otherwise specified

Parameter	Symbol	Condition	Value	Unit	
<b>Rectifier Diode</b>					
Peak Repetitive Reverse Voltage	$V_{RRM}$		1600	V	
Continuous (direct) forward current	$I_F$		35	A	
Surge (non-repetitive) forward current	$I_{FSM}$	50 Hz Single Half Sine Wave $t_p = 10\text{ ms}$	270	A	
Surge current capability	$I_{Pt}$		$T_j = 150\text{ °C}$	370	A <sup>2</sup> s
Total power dissipation	$P_{tot}$	$T_j = T_{jmax}$	$T_s = 80\text{ °C}$	56	W
Maximum Junction Temperature	$T_{jmax}$		150	°C	



## Maximum Ratings

$T_j = 25\text{ °C}$ , unless otherwise specified

Parameter	Symbol	Condition	Value	Unit
<b>Inverter Switch</b>				
Collector-emitter voltage	$V_{CES}$		1200	V
Collector current	$I_C$		25	A
Repetitive peak collector current	$I_{CRM}$	$t_p$ limited by $T_{jmax}$	50	A
Total power dissipation	$P_{tot}$	$T_j = T_{jmax}$ $T_s = 80\text{ °C}$	82	W
Gate-emitter voltage	$V_{GES}$		$\pm 20$	V
Short circuit ratings	$t_{SC}$	$V_{GE} = 15\text{ V}$ $V_{ce} = 800\text{ V}$ $T_j = 150\text{ °C}$	9,5	$\mu\text{s}$
Maximum junction temperature	$T_{jmax}$		175	$^{\circ}\text{C}$
<b>Inverter Diode</b>				
Peak repetitive reverse voltage	$V_{RRM}$		1200	V
Continuous (direct) forward current	$I_F$		25	A
Repetitive peak forward current	$I_{FRM}$	$T_j$ limited by $T_{jmax}$	50	A
Total power dissipation	$P_{tot}$	$T_j = T_{jmax}$ $T_s = 80\text{ °C}$	62	W
Maximum junction temperature	$T_{jmax}$		175	$^{\circ}\text{C}$
<b>Brake Switch</b>				
Collector-emitter voltage	$V_{CES}$		1200	V
Collector current	$I_C$		15	A
Repetitive peak collector current	$I_{CRM}$	$t_p$ limited by $T_{jmax}$	30	A
Total power dissipation	$P_{tot}$	$T_j = T_{jmax}$ $T_s = 80\text{ °C}$	60	W
Gate-emitter voltage	$V_{GES}$		$\pm 20$	V
Short circuit ratings	$t_{SC}$	$V_{GE} = 15\text{ V}$ $V_{ce} = 800\text{ V}$ $T_j = 150\text{ °C}$	9,5	$\mu\text{s}$
Maximum junction temperature	$T_{jmax}$		175	$^{\circ}\text{C}$
<b>Brake Diode</b>				
Peak repetitive reverse voltage	$V_{RRM}$		1200	V
Continuous (direct) forward current	$I_F$		10	A
Repetitive peak forward current	$I_{FRM}$	$T_j$ limited by $T_{jmax}$	20	A
Total power dissipation	$P_{tot}$	$T_j = T_{jmax}$ $T_s = 80\text{ °C}$	50	W
Maximum junction temperature	$T_{jmax}$		175	$^{\circ}\text{C}$



Vincotech

**10-FY12PMA025M7-P588A78**  
**10-PY12PMA025M7-P588A78Y**  
**10-F112PMA025M7-P588A79**  
**10-P112PMA025M7-P588A79Y**  
 datasheet

## Maximum Ratings

$T_j = 25\text{ °C}$ , unless otherwise specified

Parameter	Symbol	Condition	Value	Unit
-----------	--------	-----------	-------	------

### Module Properties

#### Thermal Properties

Storage temperature	$T_{stg}$		-40...+125	°C
Operation temperature under switching condition	$T_{jop}$		-40...(T <sub>max</sub> - 25)	°C

#### Isolation Properties

Isolation voltage	$V_{isol}$	DC Test Voltage* $t_p = 2\text{ s}$	6000	V
		AC Voltage $t_p = 1\text{ min}$	2500	V
Creepage distance			min. 12,7	mm
Clearance		for 12 mm solder pins	7,91	mm
		for 12 mm press-fit pins	7,96	
		for 17 mm housing	min. 12,7	
Comparative Tracking Index	CTI		> 200	

\*100 % tested in production



Vincotech

**10-FY12PMA025M7-P588A78**  
**10-PY12PMA025M7-P588A78Y**  
**10-F112PMA025M7-P588A79**  
**10-P112PMA025M7-P588A79Y**  
datasheet

## Characteristic Values

Parameter	Symbol	Conditions					Value			Unit
		$V_{GE}$ [V] $V_{GS}$ [V]	$V_{CE}$ [V] $V_{DS}$ [V] $V_F$ [V]	$I_C$ [A] $I_D$ [A] $I_F$ [A]	$T_j$ [°C]	Min	Typ	Max		

### Rectifier Diode

#### Static

Forward voltage	$V_F$			35	25 125		1,17 1,13		V
Reverse leakage current	$I_r$		1600		25			50	$\mu$ A

#### Thermal

Thermal resistance junction to sink	$R_{th(j-s)}$	$\lambda_{paste} = 3,4$ W/mK (PSX)					1,25		K/W
-------------------------------------	---------------	---------------------------------------	--	--	--	--	------	--	-----



Vincotech

**10-FY12PMA025M7-P588A78**  
**10-PY12PMA025M7-P588A78Y**  
**10-F112PMA025M7-P588A79**  
**10-P112PMA025M7-P588A79Y**  
 datasheet

## Characteristic Values

Parameter	Symbol	Conditions					Value			Unit
		$V_{GS}$ [V]	$V_{GE}$ [V]	$V_{DS}$ [V]	$I_D$ [A]	$T_j$ [°C]	Min	Typ	Max	

### Inverter Switch

#### Static

Parameter	Symbol	$V_{CE} = 10$ V	$V_{GS}$ [V]	$V_{GE}$ [V]	$V_{DS}$ [V]	$I_D$ [A]	$T_j$ [°C]	Min	Typ	Max	Unit
Gate-emitter threshold voltage	$V_{GE(th)}$					0,0025	25	5,4	6	6,6	V
Collector-emitter saturation voltage	$V_{CEsat}$		15			25	25 125 150		1,65 1,89 1,95	2,15	V
Collector-emitter cut-off current	$I_{CES}$		0	1200			25			70	μA
Gate-emitter leakage current	$I_{GES}$		20	0			25			500	nA
Input capacitance	$C_{ies}$								4800		pF
Output capacitance	$C_{oes}$		0	10		25			170		
Reverse transfer capacitance	$C_{res}$								57		
Gate charge	$Q_g$		15	600	25	25	25		180		nC

#### Thermal

Parameter	Symbol	Conditions	Value	Unit
Thermal resistance junction to sink	$R_{th(j-s)}$	$\lambda_{paste} = 3,4$ W/mK (PSX)	1,16	K/W

#### Dynamic

Parameter	Symbol	Conditions	$V_{GS}$ [V]	$V_{GE}$ [V]	$V_{DS}$ [V]	$I_D$ [A]	$T_j$ [°C]	Min	Typ	Max	Unit	
Turn-on delay time	$t_{d(on)}$	$R_{goff} = 16 \Omega$ $R_{gon} = 16 \Omega$					25 125 150		147 149 145		ns	
Rise time	$t_r$						25 125 150		29 33 34			
Turn-off delay time	$t_{d(off)}$		$\pm 15$	600	25		25 125 150		171 191 196			
Fall time	$t_f$						25 125 150		95 110 115			
Turn-on energy (per pulse)	$E_{on}$		$Q_{tFWD} = 2,5 \mu C$ $Q_{tFWD} = 3,9 \mu C$ $Q_{tFWD} = 4,3 \mu C$				25 125 150		2,06 2,66 2,82			mWs
Turn-off energy (per pulse)	$E_{off}$						25 125 150		1,67 2,18 2,29			



Vincotech

**10-FY12PMA025M7-P588A78**  
**10-PY12PMA025M7-P588A78Y**  
**10-F112PMA025M7-P588A79**  
**10-P112PMA025M7-P588A79Y**  
 datasheet

## Characteristic Values

Parameter	Symbol	Conditions					Value			Unit
		$V_{GE}$ [V] $V_{GS}$ [V]	$V_{CE}$ [V] $V_{DS}$ [V] $V_F$ [V]	$I_C$ [A] $I_D$ [A] $I_F$ [A]	$T_j$ [°C]	Min	Typ	Max		

### Inverter Diode

#### Static

Forward voltage	$V_F$				25 125 150		1,63 1,70 1,69	2,1	V
Reverse leakage current	$I_R$			1200	25			35	μA

#### Thermal

Thermal resistance junction to sink	$R_{th(j-s)}$	$\lambda_{paste} = 3,4$ W/mK (PSX)					1,54		K/W
-------------------------------------	---------------	---------------------------------------	--	--	--	--	------	--	-----

#### Dynamic

Peak recovery current	$I_{RRM}$				25 125 150		21 23 23		A
Reverse recovery time	$t_{rr}$				25 125 150		254 367 404		ns
Recovered charge	$Q_r$	$di/dt = 645$ A/μs $di/dt = 673$ A/μs $di/dt = 633$ A/μs	±15	600	25		2,54 3,88 4,28		μC
Reverse recovered energy	$E_{rec}$				25 125 150		0,88 1,45 1,61		mWs
Peak rate of fall of recovery current	$(di_{rr}/dt)_{max}$				25 125 150		217 134 132		A/μs



Vincotech

**10-FY12PMA025M7-P588A78**  
**10-PY12PMA025M7-P588A78Y**  
**10-F112PMA025M7-P588A79**  
**10-P112PMA025M7-P588A79Y**  
 datasheet

## Characteristic Values

Parameter	Symbol	Conditions					Value			Unit
		$V_{GE}$ [V] $V_{GS}$ [V]	$V_{CE}$ [V] $V_{DS}$ [V] $V_F$ [V]	$I_C$ [A] $I_D$ [A] $I_F$ [A]	$T_j$ [°C]	Min	Typ	Max		

### Brake Switch

#### Static

Gate-emitter threshold voltage	$V_{GE(th)}$	$V_{CE} = 10$ V			0,0015	25	5,4	6	6,6	V
Collector-emitter saturation voltage	$V_{CESat}$		15		15	25 125 150		1,70 1,95 2,01	2,15	V
Collector-emitter cut-off current	$I_{CES}$		0	1200		25			60	μA
Gate-emitter leakage current	$I_{GES}$		20	0		25			500	nA
Internal gate resistance	$r_g$							none		Ω
Input capacitance	$C_{ies}$							2900		pF
Output capacitance	$C_{oes}$		0	10		25		120		
Reverse transfer capacitance	$C_{res}$							34		
Gate charge	$Q_g$		15	600	15	25		110		nC

#### Thermal

Thermal resistance junction to sink	$R_{th(j-s)}$	$\lambda_{paste} = 3,4$ W/mK (PSX)						1,60		K/W
-------------------------------------	---------------	---------------------------------------	--	--	--	--	--	------	--	-----

#### Dynamic

Turn-on delay time	$t_{d(on)}$					25 125 150		293 257 246		ns
Rise time	$t_r$	$R_{goff} = 32$ Ω $R_{gon} = 32$ Ω				25 125 150		185 200 203		
Turn-off delay time	$t_{d(off)}$		15/0	700	15	25 125 150		398 442 450		
Fall time	$t_f$					25 125 150		66 88 92		
Turn-on energy (per pulse)	$E_{on}$	$Q_{FWD} = 1,1$ μC $Q_{FWD} = 1,9$ μC $Q_{FWD} = 2,1$ μC				25 125 150		2,95 3,57 3,74		mWs
Turn-off energy (per pulse)	$E_{off}$					25 125 150		1,33 1,71 1,81		



Vincotech

**10-FY12PMA025M7-P588A78**  
**10-PY12PMA025M7-P588A78Y**  
**10-F112PMA025M7-P588A79**  
**10-P112PMA025M7-P588A79Y**  
 datasheet

## Characteristic Values

Parameter	Symbol	Conditions					Value			Unit
		$V_{GE}$ [V]	$V_{GS}$ [V]	$V_{CE}$ [V]	$V_{DS}$ [V]	$I_C$ [A]	$I_D$ [A]	$T_j$ [°C]	Min	

### Brake Diode

#### Static

Forward voltage	$V_F$				10	25 125 150		1,61 1,69 1,69	2,1	V
Reverse leakage current	$I_R$			1200		25			25	$\mu$ A

#### Thermal

Thermal resistance junction to sink	$R_{th(j-s)}$	$\lambda_{paste} = 3,4$ W/mK (PSX)						1,91		K/W
-------------------------------------	---------------	------------------------------------	--	--	--	--	--	------	--	-----

#### Dynamic

Peak recovery current	$I_{RRM}$					25 125 150		6 7 7		A
Reverse recovery time	$t_{rr}$					25 125 150		295 485 544		ns
Recovered charge	$Q_r$	$di/dt = 69$ A/ $\mu$ s $di/dt = 69$ A/ $\mu$ s $di/dt = 67$ A/ $\mu$ s	15/0	700	15	25 125 150		1,140 1,882 2,120		$\mu$ C
Reverse recovered energy	$E_{rec}$					25 125 150		0,422 0,781 0,895		mWs
Peak rate of fall of recovery current	$(di_{rf}/dt)_{max}$					25 125 150		44 29 25		A/ $\mu$ s

### Thermistor

Rated resistance	$R$					25		22		k $\Omega$
Deviation of $R_{100}$	$\Delta_{R/R}$	$R_{100} = 1484$ $\Omega$				100	-5		5	%
Power dissipation	$P$					25		5		mW
Power dissipation constant						25		1,5		mW/K
B-value	$B_{(25/50)}$	Tol. $\pm 1$ %				25		3962		K
B-value	$B_{(25/100)}$	Tol. $\pm 1$ %				25		4000		K
Vincotech NTC Reference									I	





Vincotech

**10-FY12PMA025M7-P588A78**  
**10-PY12PMA025M7-P588A78Y**  
**10-F112PMA025M7-P588A79**  
**10-P112PMA025M7-P588A79Y**  
 datasheet

## Rectifier Diode Characteristics

**figure 1. Rectifier Diode**

Typical forward characteristics

$$I_F = f(V_F)$$

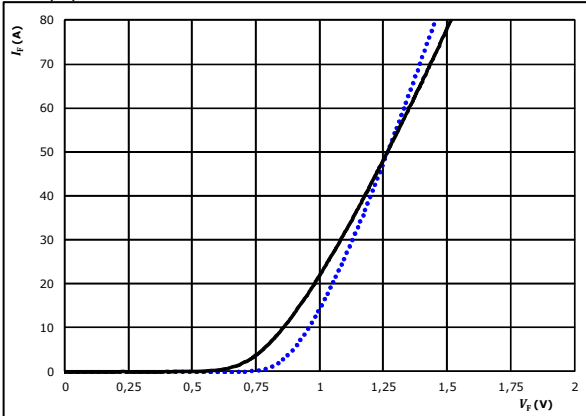

$t_p = 250 \mu s$   
 $T_j: 25 \text{ } ^\circ C$  (dotted blue line)  
 $125 \text{ } ^\circ C$  (solid black line)

**figure 2. Rectifier Diode**

Transient thermal impedance as a function of pulse width

$$Z_{th(j-s)} = f(t_p)$$

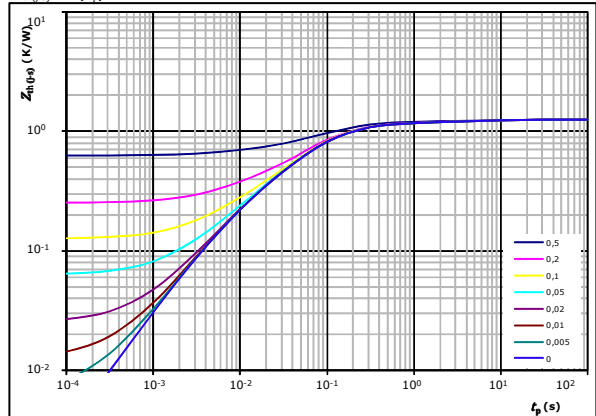

$D = t_p / T$   
 $R_{th(j-s)} = 1,25 \text{ K/W}$

Diode thermal model values

$R$ (K/W)	$\tau$ (s)
8,00E-02	5,22E+00
1,56E-01	4,18E-01
6,95E-01	8,82E-02
2,23E-01	3,07E-02
9,97E-02	5,99E-03



## Inverter Switch Characteristics

**figure 1. IGBT**

Typical output characteristics

$I_C = f(V_{CE})$

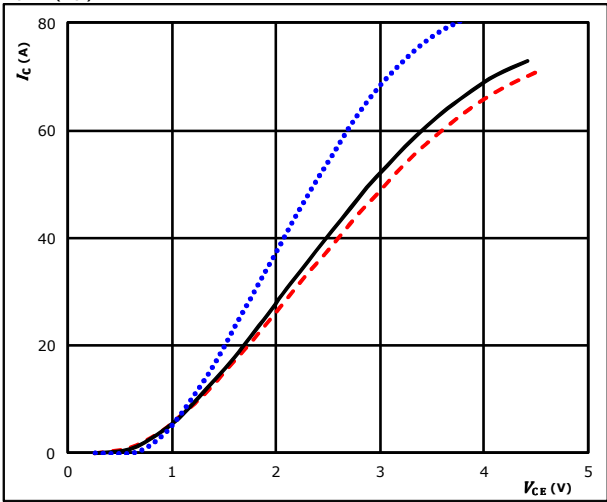

$t_p = 250 \mu s$        $T_j: 25 \text{ }^\circ C$       .....  
 $V_{GE} = 15 \text{ V}$        $T_j: 125 \text{ }^\circ C$       ———  
                           $T_j: 150 \text{ }^\circ C$       - - - -

**figure 2. IGBT**

Typical output characteristics

$I_C = f(V_{CE})$

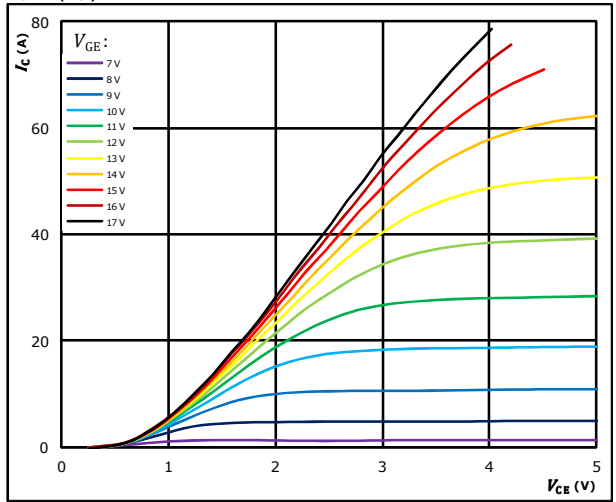

$t_p = 250 \mu s$        $T_j = 125 \text{ }^\circ C$   
 $V_{GE}$  from 7 V to 17 V in steps of 1 V

**figure 3. IGBT**

Typical transfer characteristics

$I_C = f(V_{GE})$

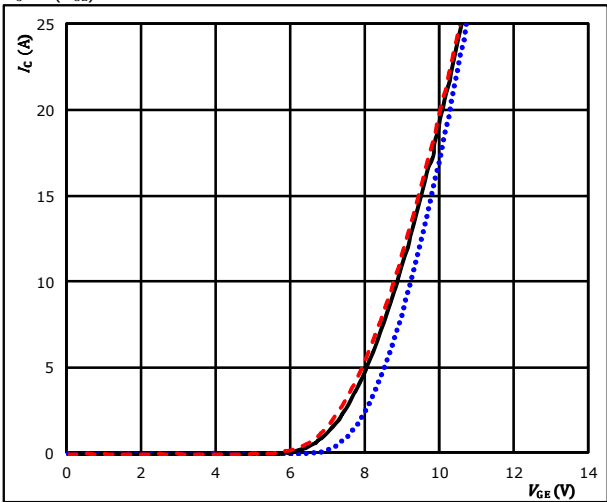

$t_p = 100 \mu s$        $T_j: 25 \text{ }^\circ C$       .....  
 $V_{CE} = 10 \text{ V}$        $T_j: 125 \text{ }^\circ C$       ———  
                           $T_j: 150 \text{ }^\circ C$       - - - -

**figure 4. IGBT**

Transient thermal impedance as function of pulse duration

$Z_{th(j-s)} = f(t_p)$

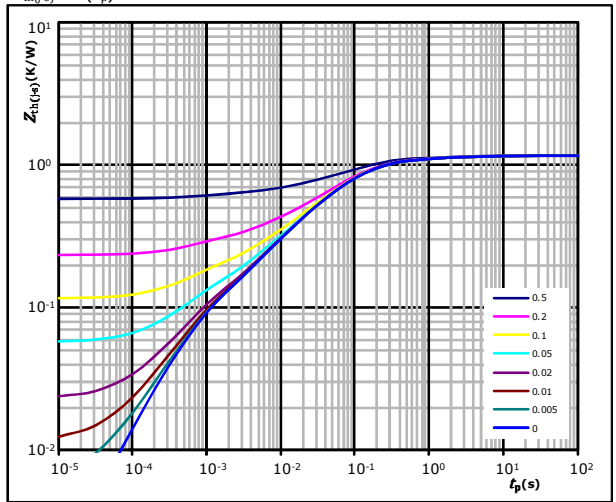

$D = t_p / T$   
 $R_{th(j-s)} = 1,16 \text{ K/W}$

IGBT thermal model values

$R$ (K/W)	$\tau$ (s)
5,33E-02	3,54E+00
1,07E-01	5,75E-01
5,05E-01	1,04E-01
2,68E-01	3,30E-02
1,51E-01	7,35E-03
7,80E-02	6,52E-04



Vincotech

**10-FY12PMA025M7-P588A78**  
**10-PY12PMA025M7-P588A78Y**  
**10-F112PMA025M7-P588A79**  
**10-P112PMA025M7-P588A79Y**  
datasheet

## Inverter Switch Characteristics

**figure 5. IGBT**

Safe operating area

$$I_C = f(V_{CE})$$

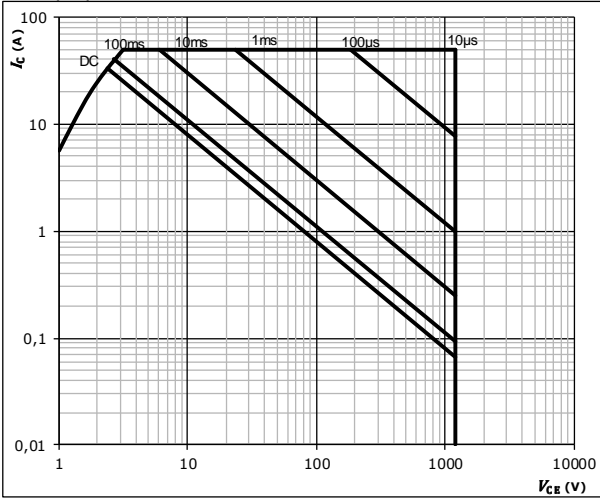

$D =$  single pulse  
 $T_s = 80$  °C  
 $V_{GE} = \pm 15$  V  
 $T_j = T_{jmax}$



### Inverter Diode Characteristics

**figure 1.** FWD

Typical forward characteristics

$$I_F = f(V_F)$$

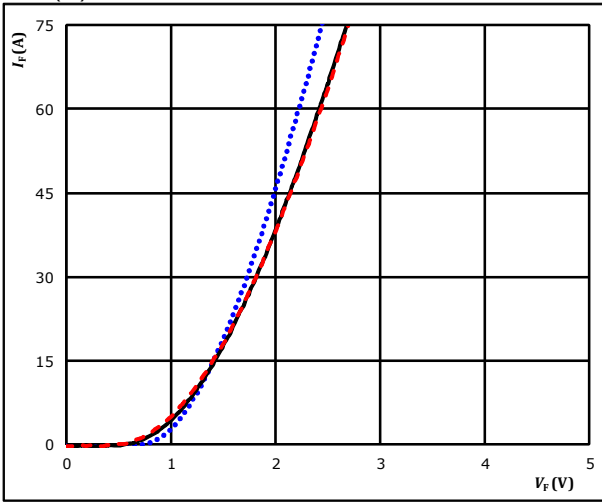

$t_p = 250 \mu s$   
 $T_j$ : 25 °C .....  
 125 °C ———  
 150 °C - - - -

**figure 2.** FWD

Transient thermal impedance as a function of pulse width

$$Z_{th(j-s)} = f(t_p)$$

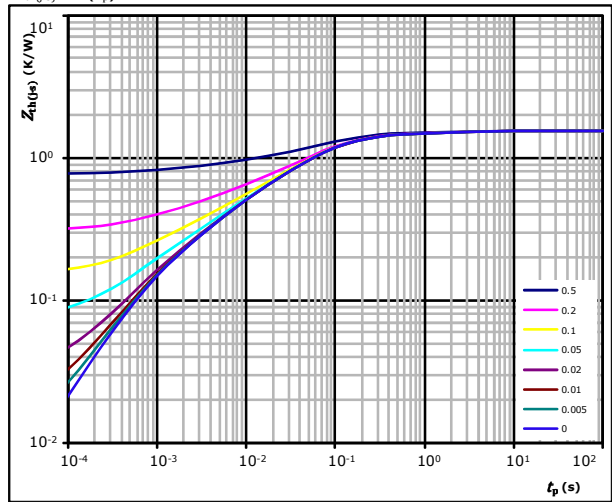

$D = t_p / T$   
 $R_{th(j-s)} = 1,54 \text{ K/W}$   
 FWD thermal model values

R (K/W)	$\tau$ (s)
4,69E-02	5,05E+00
1,06E-01	7,09E-01
5,57E-01	1,01E-01
4,68E-01	3,22E-02
2,35E-01	5,52E-03
8,77E-02	1,01E-03
4,01E-02	5,52E-04



## Brake Switch Characteristics

**figure 1.** IGBT

Typical output characteristics

$$I_C = f(V_{CE})$$

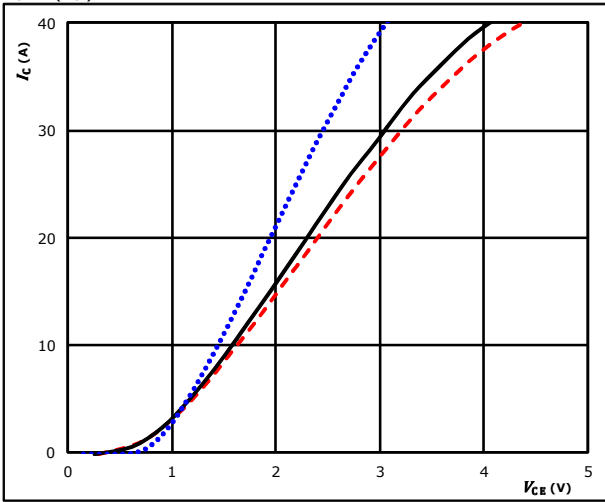

$t_p = 250 \mu s$   $T_j: 25 \text{ }^\circ C$  .....  
 $V_{GE} = 15 V$   $T_j: 125 \text{ }^\circ C$  ———  
 $T_j: 150 \text{ }^\circ C$  - - - - -

**figure 2.** IGBT

Typical output characteristics

$$I_C = f(V_{CE})$$

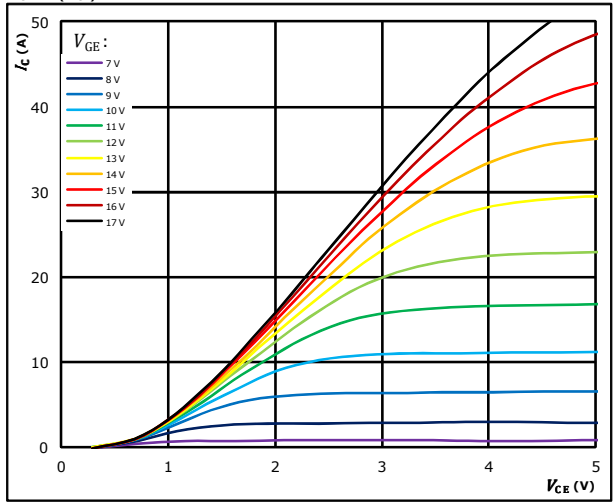

$t_p = 250 \mu s$   
 $T_j = 150 \text{ }^\circ C$   
 $V_{GE}$  from 7 V to 17 V in steps of 1 V

**figure 3.** IGBT

Typical transfer characteristics

$$I_C = f(V_{GE})$$

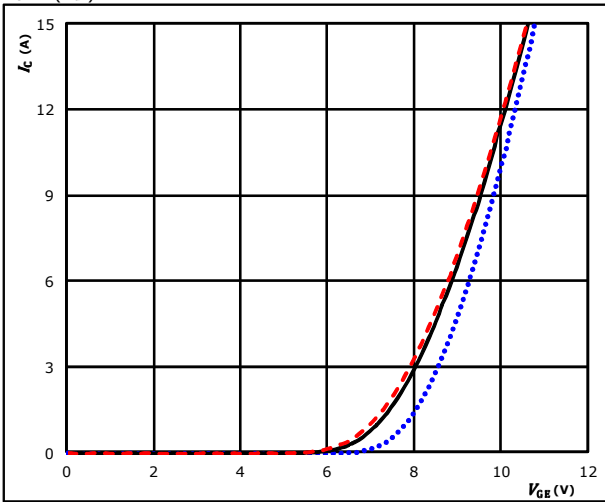

$t_p = 100 \mu s$   $T_j: 25 \text{ }^\circ C$  .....  
 $V_{CE} = 10 V$   $T_j: 125 \text{ }^\circ C$  ———  
 $T_j: 150 \text{ }^\circ C$  - - - - -

**figure 4.** IGBT

Transient thermal impedance as function of pulse duration

$$Z_{th(j-s)} = f(t_p)$$

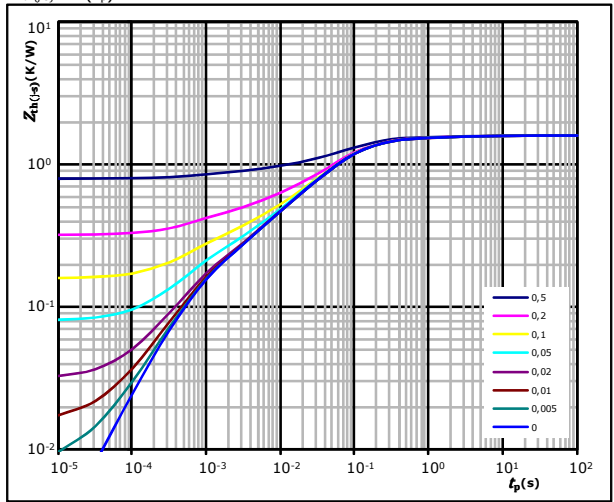

$D = t_p / T$   
 $R_{th(j-s)} = 1,60 \text{ K/W}$

IGBT thermal model values

$R$ (K/W)	$\tau$ (s)
4,90E-02	4,40E+00
1,40E-01	5,34E-01
8,04E-01	8,02E-02
2,98E-01	2,57E-02
1,69E-01	5,09E-03
1,35E-01	6,41E-04



Vincotech

**10-FY12PMA025M7-P588A78**  
**10-PY12PMA025M7-P588A78Y**  
**10-F112PMA025M7-P588A79**  
**10-P112PMA025M7-P588A79Y**  
datasheet

## Brake Switch Characteristics

figure 5. IGBT

Safe operating area

$$I_C = f(V_{CE})$$

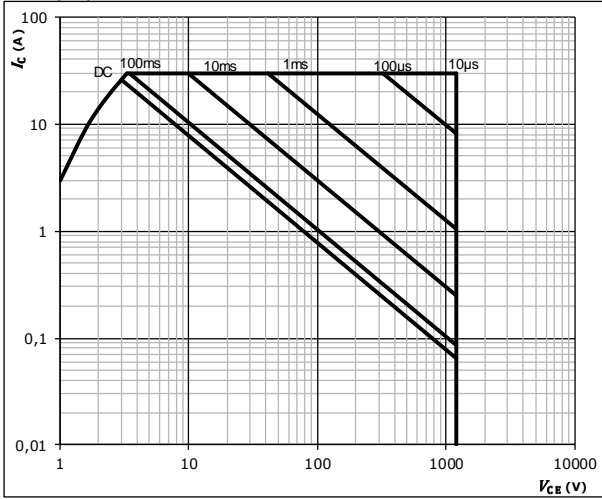

$D =$  single pulse  
 $T_s =$  80 °C  
 $V_{GE} =$  0 V  
 $T_j = T_{jmax}$



## Brake Diode Characteristics

**figure 1.** FWD

Typical forward characteristics

$$I_F = f(V_F)$$

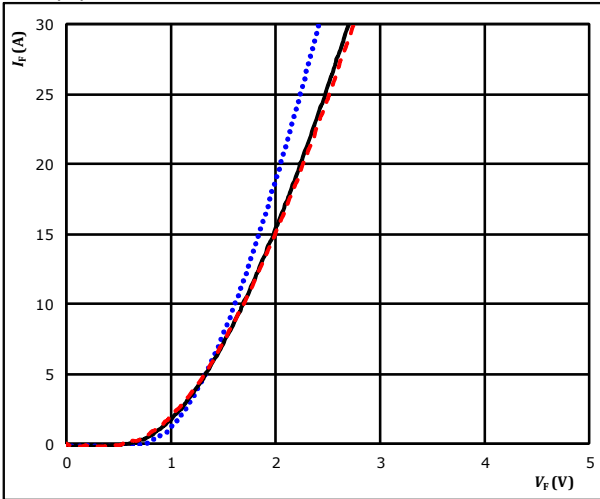

$t_p = 250 \mu\text{s}$   
 $T_j$ : 25 °C (dotted blue), 125 °C (solid black), 150 °C (dashed red)

**figure 2.** FWD

Transient thermal impedance as a function of pulse width

$$Z_{th(j-s)} = f(t_p)$$

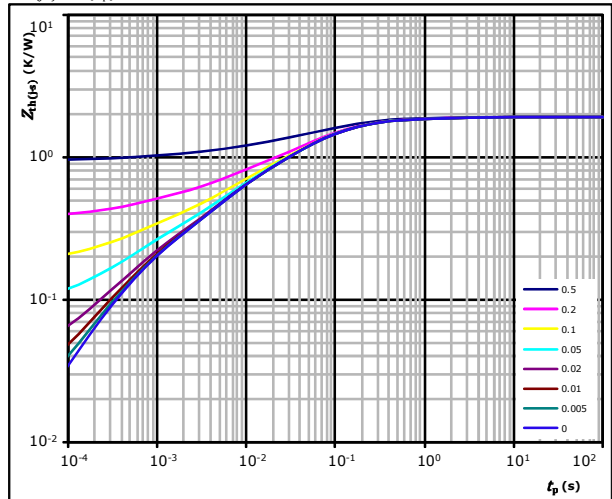

$$D = \frac{t_p}{T}$$

$$R_{th(j-s)} = 1,91 \text{ K/W}$$

FWD thermal model values

$R$ (K/W)	$\tau$ (s)
9,38E-02	2,25E+00
3,43E-01	2,12E-01
8,53E-01	5,82E-02
3,59E-01	9,80E-03
1,37E-01	2,88E-03
1,26E-01	4,78E-04



## Thermistor Characteristics

**figure 1.** Thermistor  
Typical NTC characteristic as a function of temperature

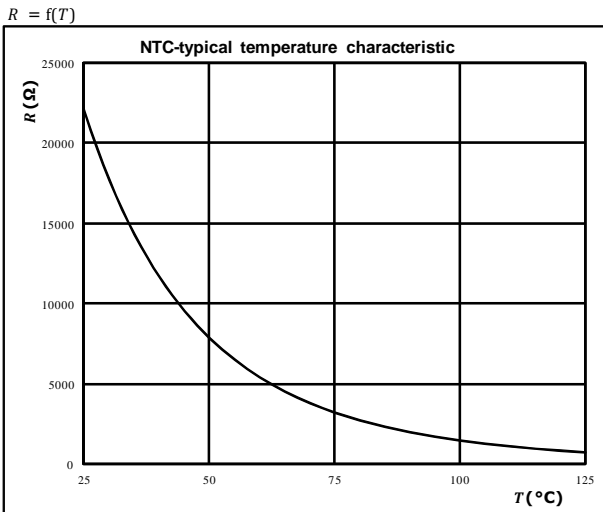



## Inverter Switching Characteristics

**figure 1.** IGBT

Typical switching energy losses as a function of collector current

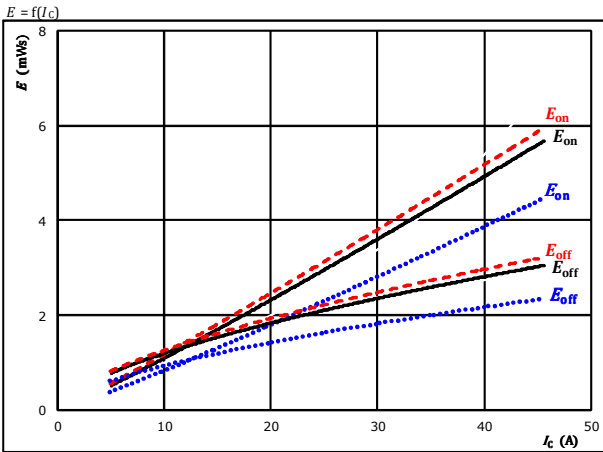

With an inductive load at

$V_{CE} = 600$ V	$T_j: 25$ °C	.....
$V_{GE} = \pm 15$ V	$125$ °C	————
$R_{g(on)} = 16$ Ω	$150$ °C	- - - -
$R_{g(off)} = 16$ Ω		

**figure 2.** IGBT

Typical switching energy losses as a function of gate resistor

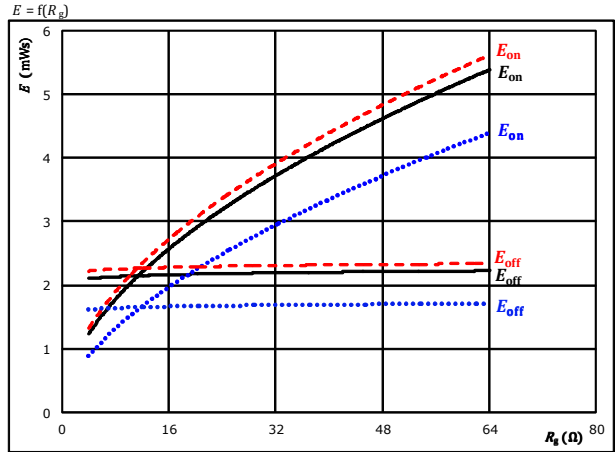

With an inductive load at

$V_{CE} = 600$ V	$T_j: 25$ °C	.....
$V_{GE} = \pm 15$ V	$125$ °C	————
$I_C = 25$ A	$150$ °C	- - - -

**figure 3.** FWD

Typical reverse recovered energy loss as a function of collector current

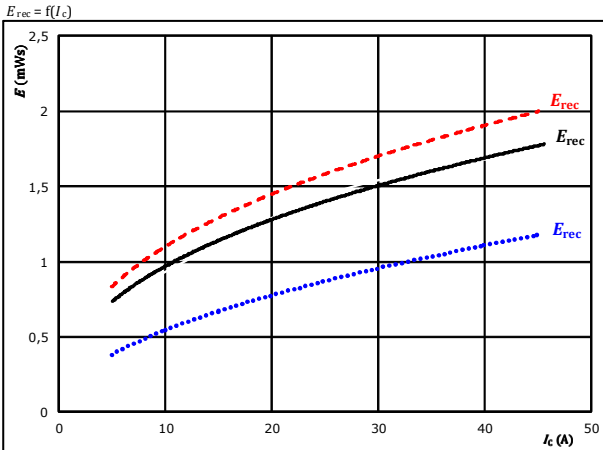

With an inductive load at

$V_{CE} = 600$ V	$T_j: 25$ °C	.....
$V_{GE} = \pm 15$ V	$125$ °C	————
$R_{g(on)} = 16$ Ω	$150$ °C	- - - -

**figure 4.** FWD

Typical reverse recovered energy loss as a function of gate resistor

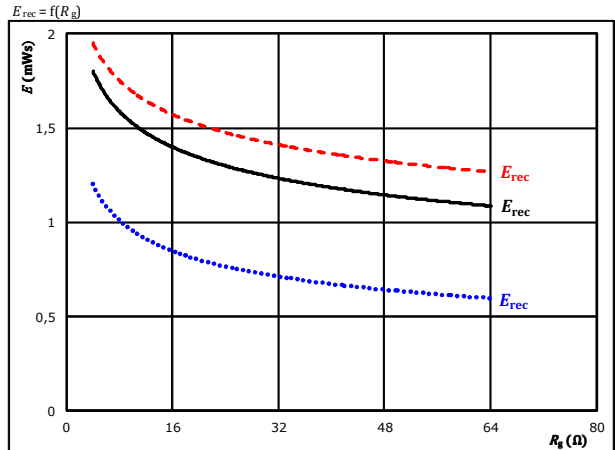

With an inductive load at

$V_{CE} = 600$ V	$T_j: 25$ °C	.....
$V_{GE} = \pm 15$ V	$125$ °C	————
$I_C = 25$ A	$150$ °C	- - - -



## Inverter Switching Characteristics

**figure 5. IGBT**

Typical switching times as a function of collector current

$$t = f(I_c)$$

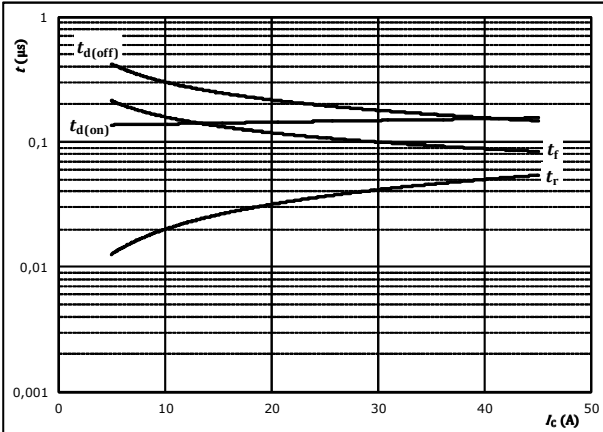

With an inductive load at

$T_j =$	150	°C
$V_{CE} =$	600	V
$V_{GE} =$	±15	V
$R_{g(on)} =$	16	Ω
$R_{g(off)} =$	16	Ω

**figure 6. IGBT**

Typical switching times as a function of gate resistor

$$t = f(R_g)$$

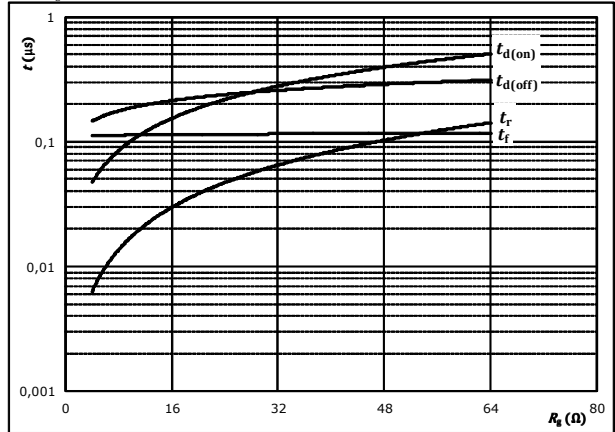

With an inductive load at

$T_j =$	150	°C
$V_{CE} =$	600	V
$V_{GE} =$	±15	V
$I_c =$	25	A

**figure 7. FWD**

Typical reverse recovery time as a function of collector current

$$t_{rr} = f(I_c)$$

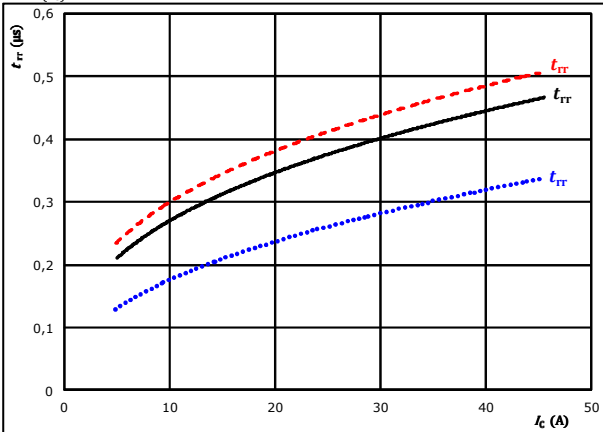

At	$V_{CE} =$	600	V	$T_j:$	25 °C	.....
	$V_{GE} =$	±15	V		125 °C	————
	$R_{g(on)} =$	16	Ω		150 °C	- - - -

**figure 8. FWD**

Typical reverse recovery time as a function of IGBT turn on gate resistor

$$t_{rr} = f(R_{g(on)})$$

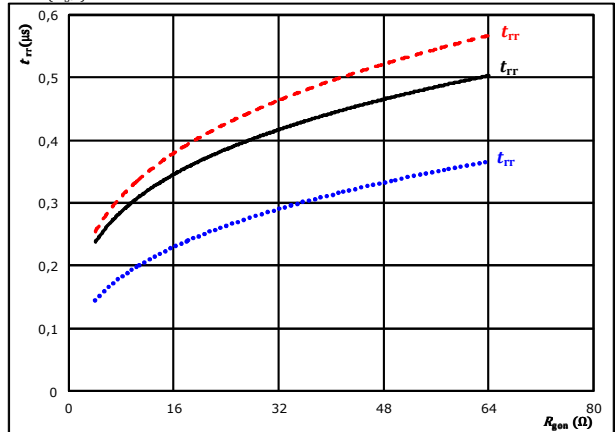

At	$V_{CE} =$	600	V	$T_j:$	25 °C	.....
	$V_{GE} =$	±15	V		125 °C	————
	$I_c =$	25	A		150 °C	- - - -



## Inverter Switching Characteristics

**figure 9.** FWD

Typical recovered charge as a function of collector current

$Q_r = f(I_c)$

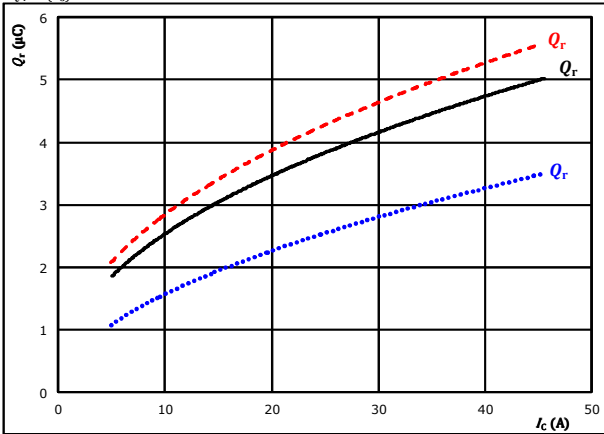

At  $V_{CE} = 600$  V  $T_j = 25$  °C .....  
 $V_{GE} = \pm 15$  V  $T_j = 125$  °C ———  
 $R_{gdn} = 16$  Ω  $T_j = 150$  °C - - - - -

**figure 10.** FWD

Typical recovered charge as a function of IGBT turn on gate resistor

$Q_r = f(R_{gdn})$

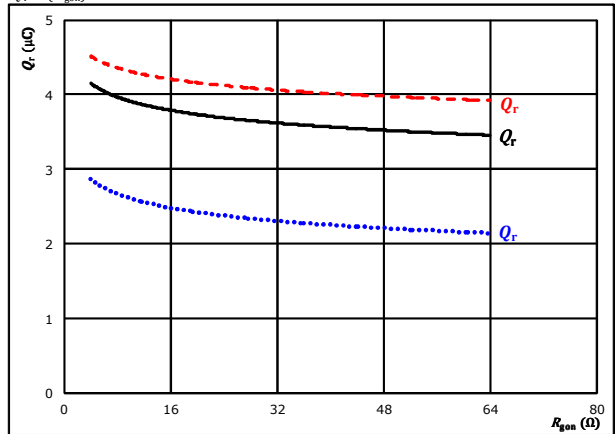

At  $V_{CE} = 600$  V  $T_j = 25$  °C .....  
 $V_{GE} = \pm 15$  V  $T_j = 125$  °C ———  
 $I_c = 25$  A  $T_j = 150$  °C - - - - -

**figure 11.** FWD

Typical peak reverse recovery current current as a function of collector current

$I_{RM} = f(I_c)$

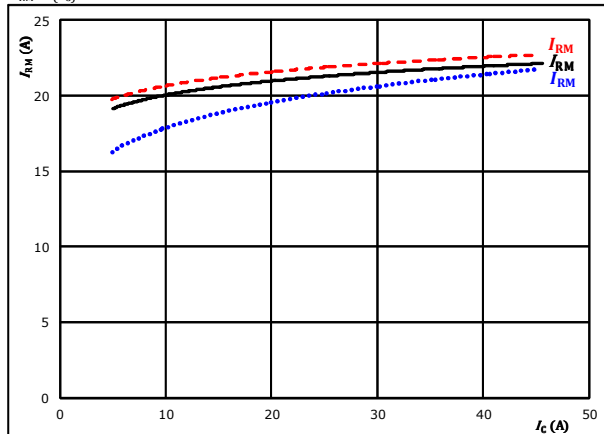

At  $V_{CE} = 600$  V  $T_j = 25$  °C .....  
 $V_{GE} = \pm 15$  V  $T_j = 125$  °C ———  
 $R_{gdn} = 16$  Ω  $T_j = 150$  °C - - - - -

**figure 12.** FWD

Typical peak reverse recovery current as a function of IGBT turn on gate resistor

$I_{RM} = f(R_{gdn})$

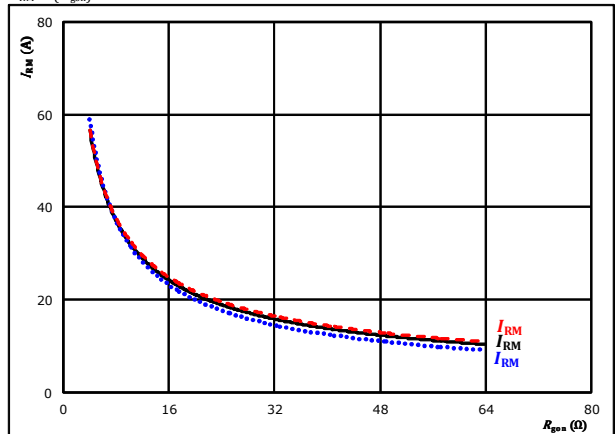

At  $V_{CE} = 600$  V  $T_j = 25$  °C .....  
 $V_{GE} = \pm 15$  V  $T_j = 125$  °C ———  
 $I_c = 25$  A  $T_j = 150$  °C - - - - -



Vincotech

**10-FY12PMA025M7-P588A78**  
**10-PY12PMA025M7-P588A78Y**  
**10-F112PMA025M7-P588A79**  
**10-P112PMA025M7-P588A79Y**  
 datasheet

## Inverter Switching Characteristics

**figure 13.** FWD

Typical rate of fall of forward and reverse recovery current as a function of collector current  
 $di_f/dt, di_{rr}/dt = f(I_c)$

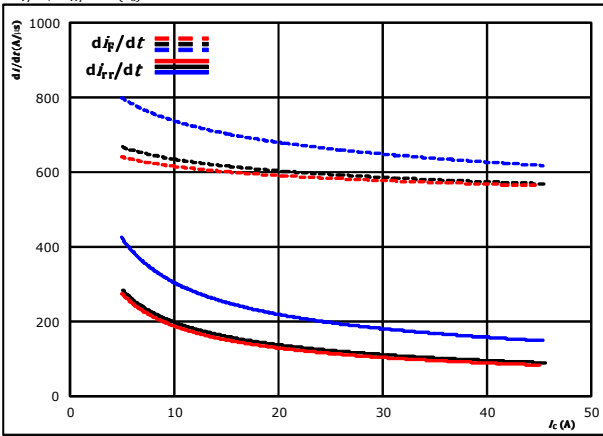

At  $V_{CE} = 600$  V  $T_j = 25$  °C (dotted)  
 $V_{GE} = \pm 15$  V  $T_j = 125$  °C (solid)  
 $R_{g0n} = 16$  Ω  $T_j = 150$  °C (dashed)

**figure 14.** FWD

Typical rate of fall of forward and reverse recovery current as a function of IGBT turn on gate resistor  
 $di_f/dt, di_{rr}/dt = f(R_{g0n})$

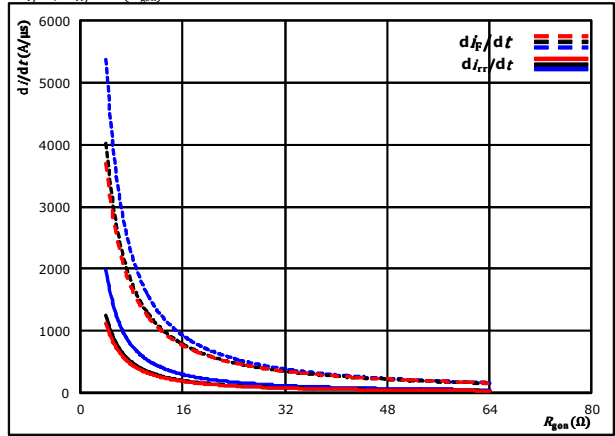

At  $V_{CE} = 600$  V  $T_j = 25$  °C (dotted)  
 $V_{GE} = \pm 15$  V  $T_j = 125$  °C (solid)  
 $I_c = 25$  A  $T_j = 150$  °C (dashed)

**figure 15.** IGBT

Reverse bias safe operating area  
 $I_c = f(V_{CE})$

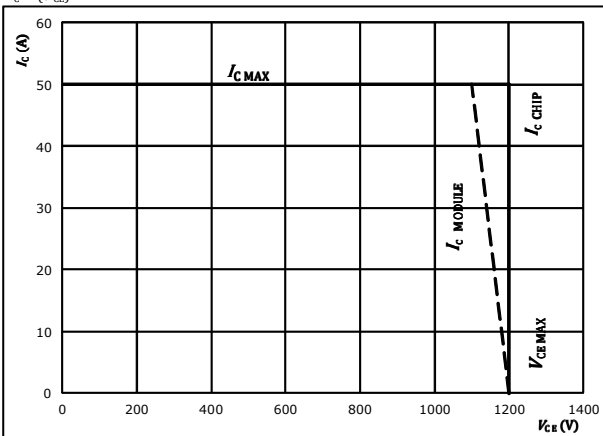

At  $T_j = 175$  °C  
 $R_{g0n} = 16$  Ω  
 $R_{g0ff} = 16$  Ω



## Inverter Switching Definitions

**General conditions**

$T_j$	=	125 °C
$R_{gon}$	=	16 Ω
$R_{goff}$	=	16 Ω

**figure 1.** IGBT

Turn-off Switching Waveforms & definition of  $t_{doff}$ ,  $t_{Eoff}$  ( $t_{Eoff}$  = integrating time for  $E_{off}$ )

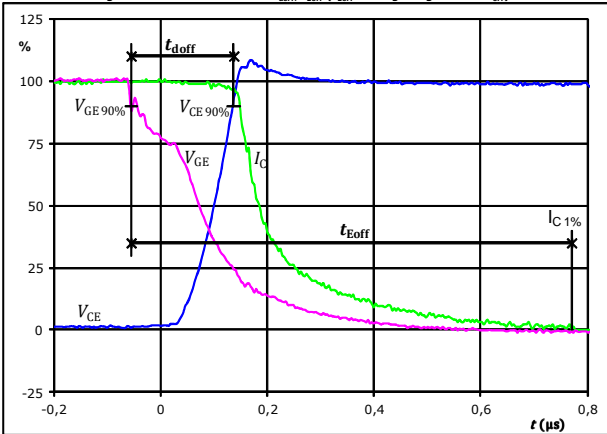

$V_{GE}(0\%) =$	-15	V
$V_{GE}(100\%) =$	15	V
$V_C(100\%) =$	600	V
$I_C(100\%) =$	25	A
$t_{doff} =$	0,191	μs
$t_{Eoff} =$	0,826	μs

**figure 2.** IGBT

Turn-on Switching Waveforms & definition of  $t_{don}$ ,  $t_{Eon}$  ( $t_{Eon}$  = integrating time for  $E_{on}$ )

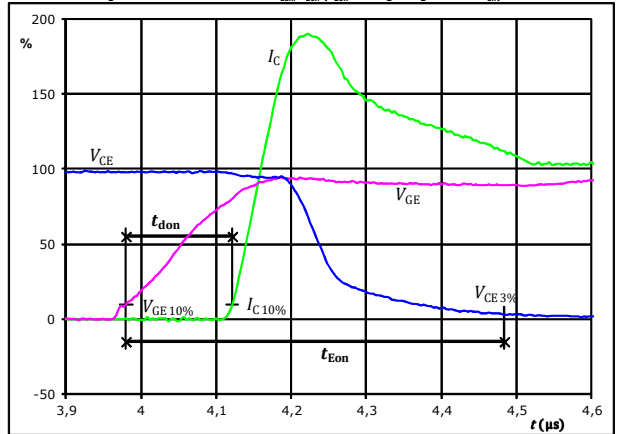

$V_{GE}(0\%) =$	-15	V
$V_{GE}(100\%) =$	15	V
$V_C(100\%) =$	600	V
$I_C(100\%) =$	25	A
$t_{don} =$	0,149	μs
$t_{Eon} =$	0,504	μs

**figure 3.** IGBT

Turn-off Switching Waveforms & definition of  $t_f$

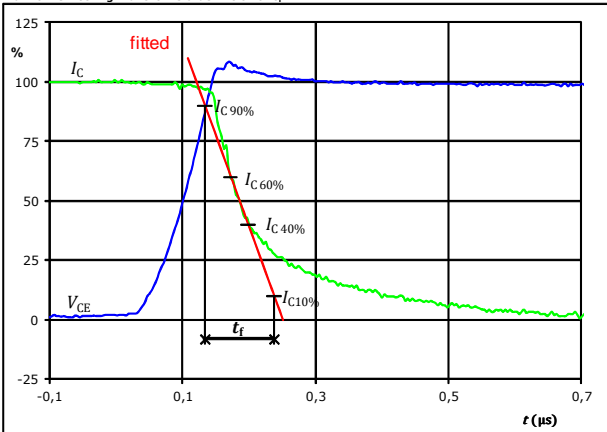

$V_C(100\%) =$	600	V
$I_C(100\%) =$	25	A
$t_f =$	0,110	μs

**figure 4.** IGBT

Turn-on Switching Waveforms & definition of  $t_r$

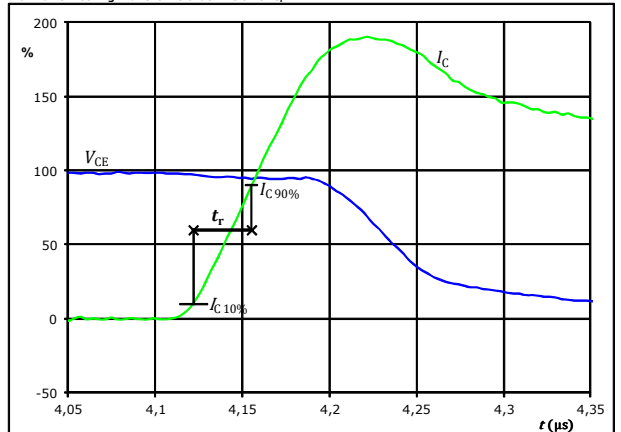

$V_C(100\%) =$	600	V
$I_C(100\%) =$	25	A
$t_r =$	0,033	μs



Vincotech

**10-FY12PMA025M7-P588A78**  
**10-PY12PMA025M7-P588A78Y**  
**10-F112PMA025M7-P588A79**  
**10-P112PMA025M7-P588A79Y**  
 datasheet

## Inverter Switching Characteristics

figure 5. IGBT

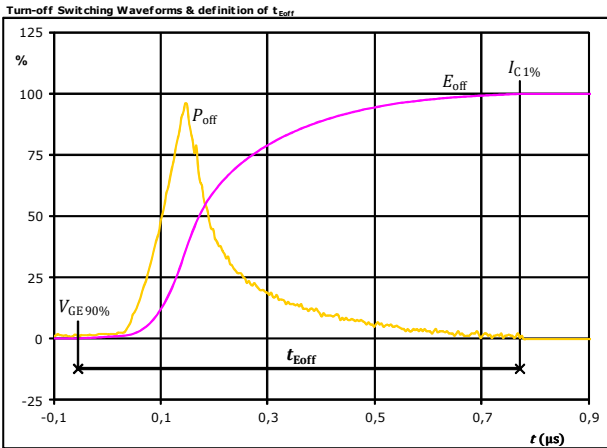

$P_{off}(100\%) =$	15,13	kW
$E_{off}(100\%) =$	2,18	mJ
$t_{Eoff} =$	0,83	µs

figure 6. IGBT

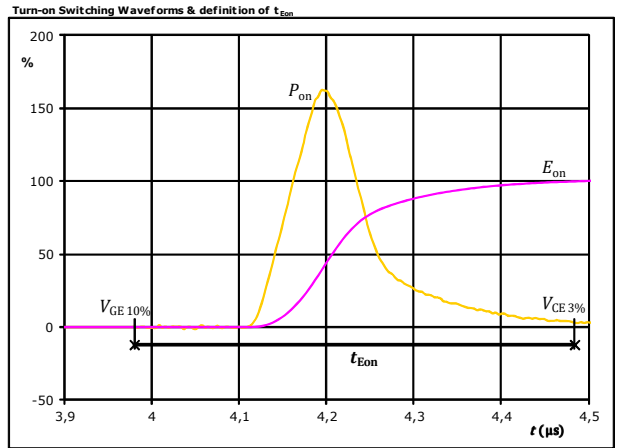

$P_{on}(100\%) =$	15,13	kW
$E_{on}(100\%) =$	2,66	mJ
$t_{Eon} =$	0,50	µs

figure 7. FWD

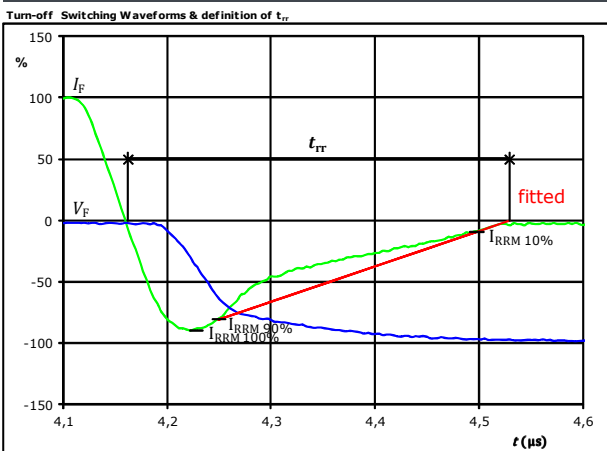

$V_F(100\%) =$	600	V
$I_F(100\%) =$	25	A
$I_{RRM}(100\%) =$	-23	A
$t_{rr} =$	0,367	µs



Vincotech

**10-FY12PMA025M7-P588A78**  
**10-PY12PMA025M7-P588A78Y**  
**10-F112PMA025M7-P588A79**  
**10-P112PMA025M7-P588A79Y**  
 datasheet

## Inverter Switching Characteristics

**figure 8.** FWD

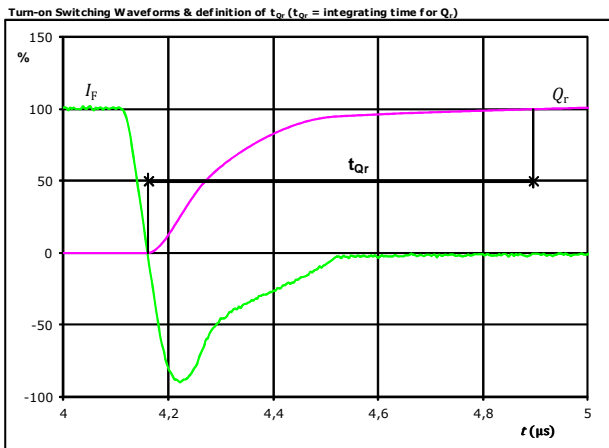

$I_F$ (100%) =	25	A
$Q_r$ (100%) =	3,88	$\mu\text{C}$
$t_{Qr}$ =	0,73	$\mu\text{s}$

**figure 9.** FWD

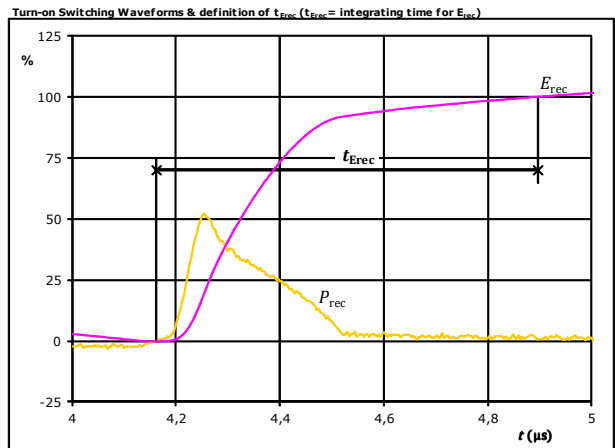

$P_{rec}$ (100%) =	15,13	kW
$E_{rec}$ (100%) =	1,45	mJ
$t_{Erec}$ =	0,73	$\mu\text{s}$

## Brake Switching Characteristics

**figure 1.** IGBT

Typical switching energy losses as a function of collector current

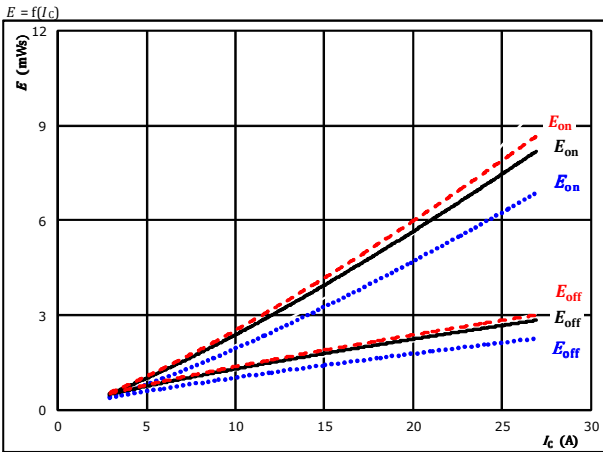

With an inductive load at

$V_{CE} = 700$ V	$T_j:$ 25 °C	.....
$V_{GE} = 15/0$ V	125 °C	————
$R_{gon} = 32$ Ω	150 °C	-----
$R_{goff} = 32$ Ω		

**figure 2.** IGBT

Typical switching energy losses as a function of gate resistor

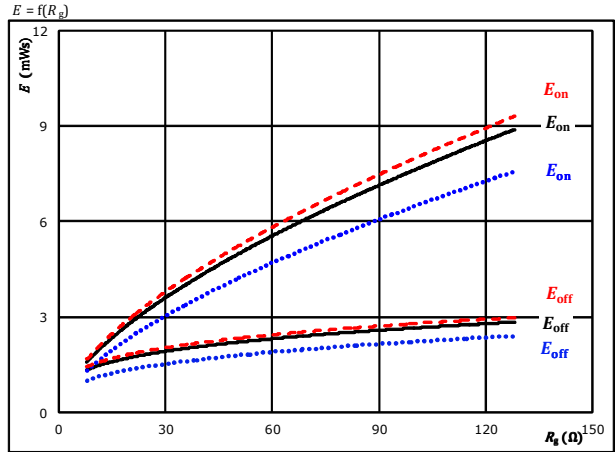

With an inductive load at

$V_{CE} = 700$ V	$T_j:$ 25 °C	.....
$V_{GE} = 15/0$ V	125 °C	————
$I_c = 15$ A	150 °C	-----

**figure 3.** FWD

Typical reverse recovered energy loss as a function of collector current

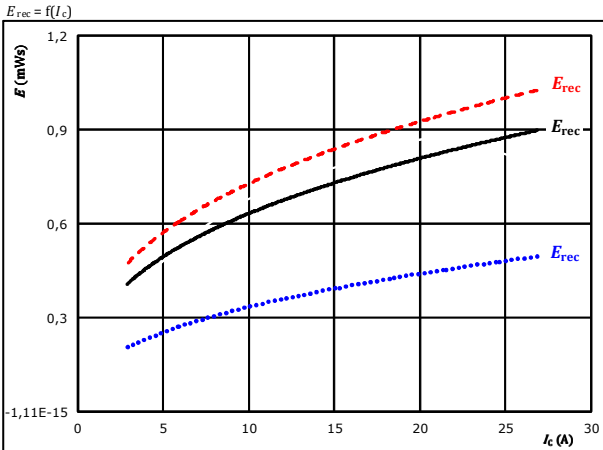

With an inductive load at

$V_{CE} = 700$ V	$T_j:$ 25 °C	.....
$V_{GE} = 15/0$ V	125 °C	————
$R_{gon} = 32$ Ω	150 °C	-----

**figure 4.** FWD

Typical reverse recovered energy loss as a function of gate resistor

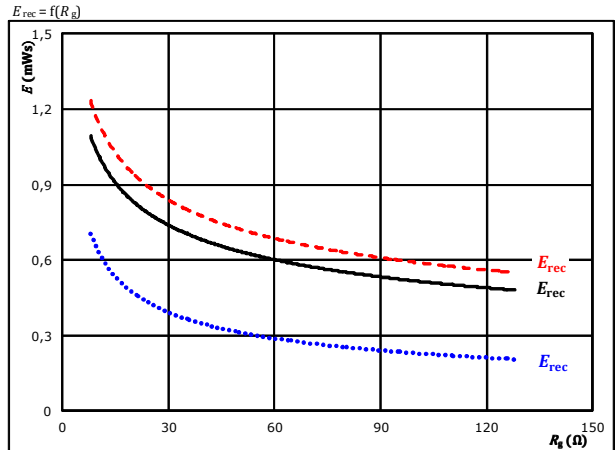

With an inductive load at

$V_{CE} = 700$ V	$T_j:$ 25 °C	.....
$V_{GE} = 15/0$ V	125 °C	————
$I_c = 15$ A	150 °C	-----





Vincotech

**10-FY12PMA025M7-P588A78**  
**10-PY12PMA025M7-P588A78Y**  
**10-F112PMA025M7-P588A79**  
**10-P112PMA025M7-P588A79Y**  
 datasheet

## Brake Switching Characteristics

**figure 5. IGBT**  
 Typical switching times as a function of collector current

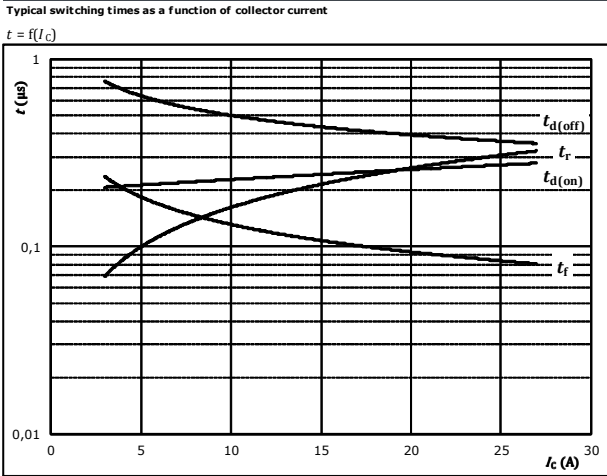

**figure 6. IGBT**  
 Typical switching times as a function of gate resistor

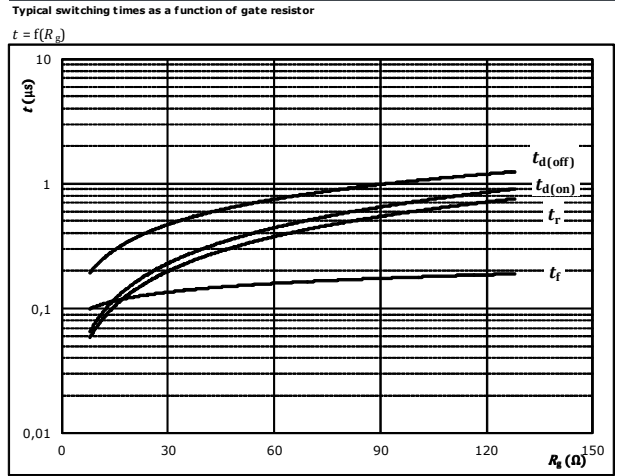

**figure 7. FWD**  
 Typical reverse recovery time as a function of collector current

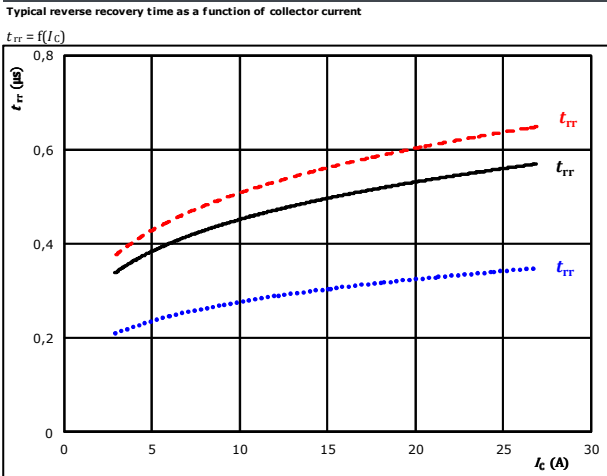

**figure 8. FWD**  
 Typical reverse recovery time as a function of IGBT turn on gate resistor

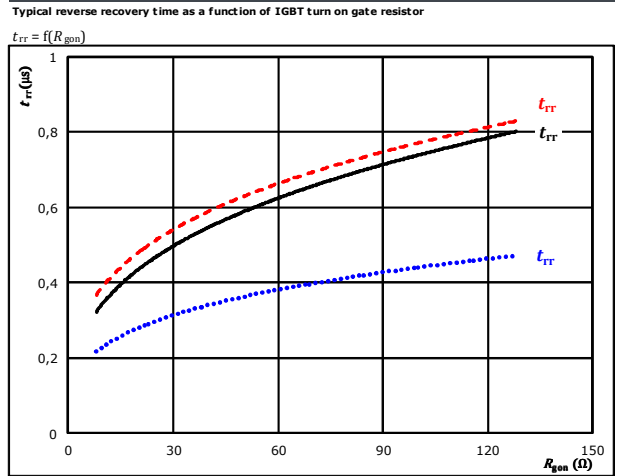



## Brake Switching Characteristics

**figure 9.** FWD

Typical recovered charge as a function of collector current

$$Q_r = f(I_c)$$

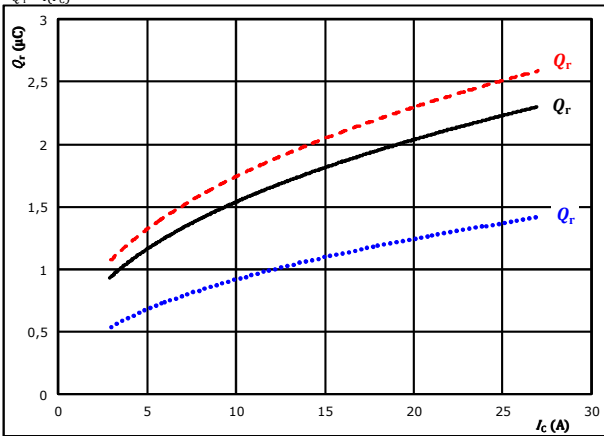

At  $V_{CE} = 700$  V  $T_j = 25$  °C .....  
 $V_{GE} = 15/0$  V  $T_j = 125$  °C ———  
 $R_{gon} = 32$   $\Omega$   $T_j = 150$  °C - - - - -

**figure 10.** FWD

Typical recovered charge as a function of IGBT turn on gate resistor

$$Q_r = f(R_{gon})$$

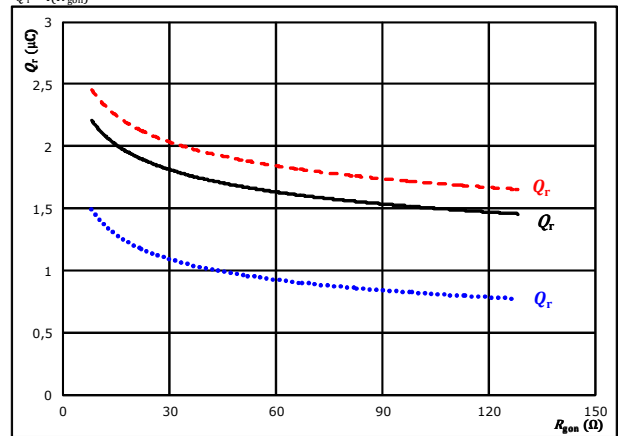

At  $V_{CE} = 700$  V  $T_j = 25$  °C .....  
 $V_{GE} = 15/0$  V  $T_j = 125$  °C ———  
 $I_c = 15$  A  $T_j = 150$  °C - - - - -

**figure 11.** FWD

Typical peak reverse recovery current current as a function of collector current

$$I_{RM} = f(I_c)$$

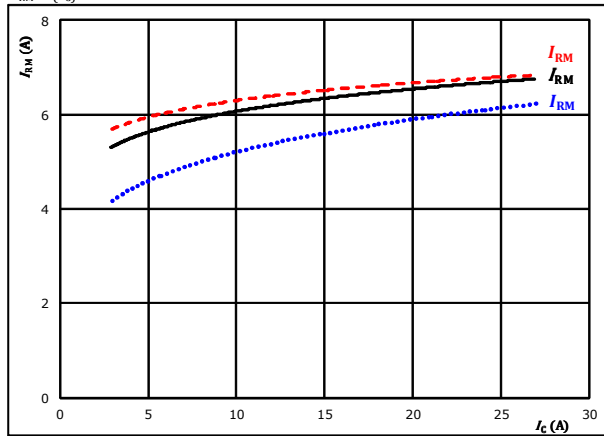

At  $V_{CE} = 700$  V  $T_j = 25$  °C .....  
 $V_{GE} = 15/0$  V  $T_j = 125$  °C ———  
 $R_{gon} = 32$   $\Omega$   $T_j = 150$  °C - - - - -

**figure 12.** FWD

Typical peak reverse recovery current current as a function of IGBT turn on gate resistor

$$I_{RM} = f(R_{gon})$$

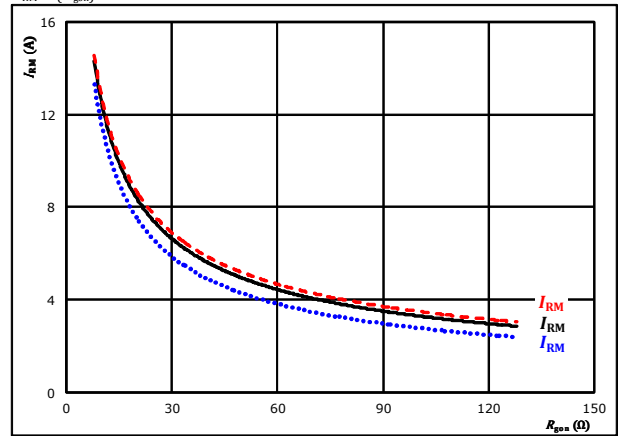

At  $V_{CE} = 700$  V  $T_j = 25$  °C .....  
 $V_{GE} = 15/0$  V  $T_j = 125$  °C ———  
 $I_c = 15$  A  $T_j = 150$  °C - - - - -



Vincotech

**10-FY12PMA025M7-P588A78**  
**10-PY12PMA025M7-P588A78Y**  
**10-F112PMA025M7-P588A79**  
**10-P112PMA025M7-P588A79Y**  
 datasheet

## Brake Switching Characteristics

**figure 13.** FWD

Typical rate of fall of forward and reverse recovery current as a function of collector current  
 $di_f/dt, di_{rr}/dt = f(I_c)$

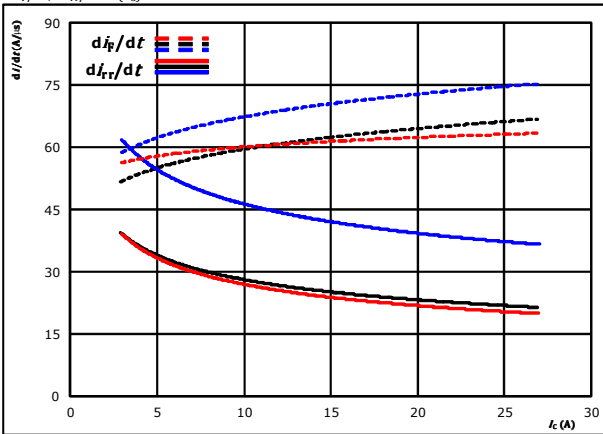

At  $V_{CE} = 700$  V  $T_j = 25$  °C .....  
 $V_{GE} = 15/0$  V  $T_j = 125$  °C ———  
 $R_{g0n} = 32$  Ω  $T_j = 150$  °C - - - - -

**figure 14.** FWD

Typical rate of fall of forward and reverse recovery current as a function of IGBT turn on gate resistor  
 $di_f/dt, di_{rr}/dt = f(R_{g0n})$

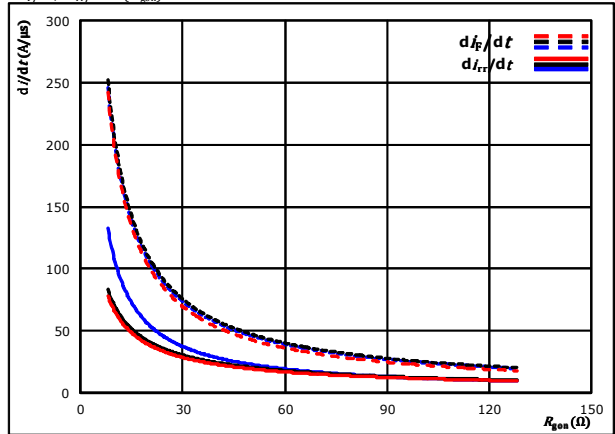

At  $V_{CE} = 700$  V  $T_j = 25$  °C .....  
 $V_{GE} = 15/0$  V  $T_j = 125$  °C ———  
 $I_c = 15$  A  $T_j = 150$  °C - - - - -

**figure 15.** IGBT

Reverse bias safe operating area  
 $I_c = f(V_{CE})$

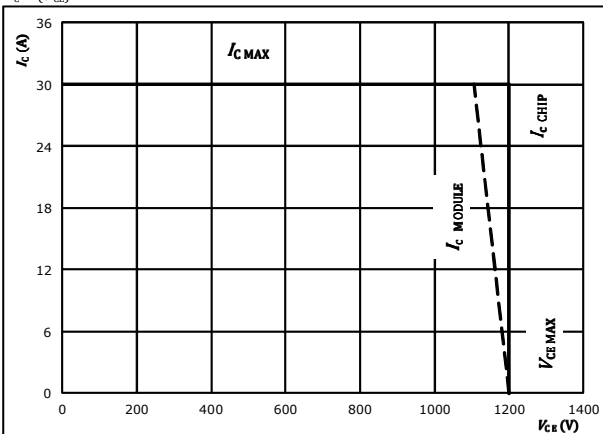

At  $T_j = 175$  °C  
 $R_{g0n} = 32$  Ω  
 $R_{g0ff} = 32$  Ω



## Brake Switching Definitions

**General conditions**

$T_j$	=	125 °C
$R_{gon}$	=	32 Ω
$R_{goff}$	=	32 Ω

**figure 1.** IGBT

Turn-off Switching Waveforms & definition of  $t_{doff}$ ,  $t_{Eoff}$  ( $t_{Eoff}$  = integrating time for  $E_{off}$ )

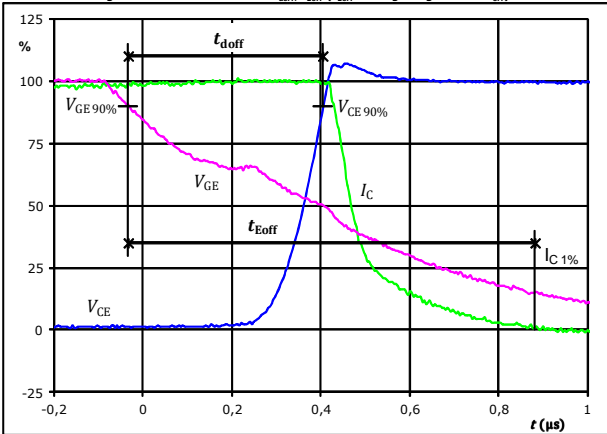

$V_{GE}(0\%) =$	0	V
$V_{GE}(100\%) =$	15	V
$V_C(100\%) =$	700	V
$I_C(100\%) =$	15	A
$t_{doff} =$	0,442	µs
$t_{Eoff} =$	0,915	µs

**figure 2.** IGBT

Turn-on Switching Waveforms & definition of  $t_{don}$ ,  $t_{Eon}$  ( $t_{Eon}$  = integrating time for  $E_{on}$ )

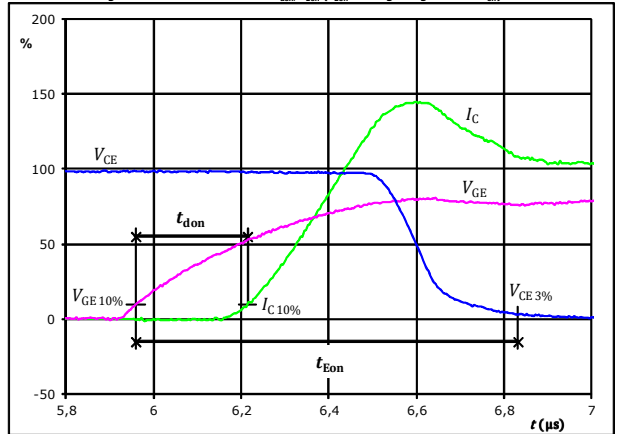

$V_{GE}(0\%) =$	0	V
$V_{GE}(100\%) =$	15	V
$V_C(100\%) =$	700	V
$I_C(100\%) =$	15	A
$t_{don} =$	0,257	µs
$t_{Eon} =$	0,872	µs

**figure 3.** IGBT

Turn-off Switching Waveforms & definition of  $t_f$

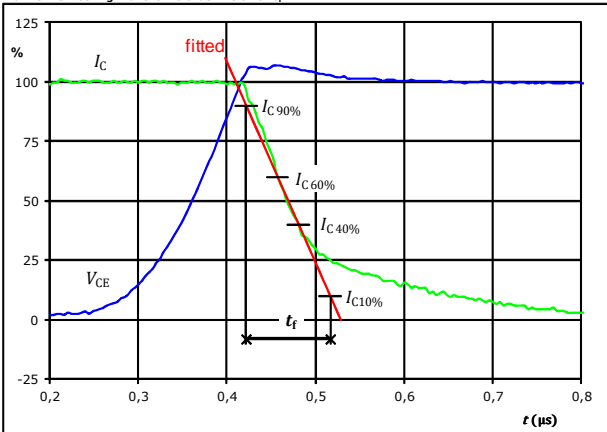

$V_C(100\%) =$	700	V
$I_C(100\%) =$	15	A
$t_f =$	0,088	µs

**figure 4.** IGBT

Turn-on Switching Waveforms & definition of  $t_r$

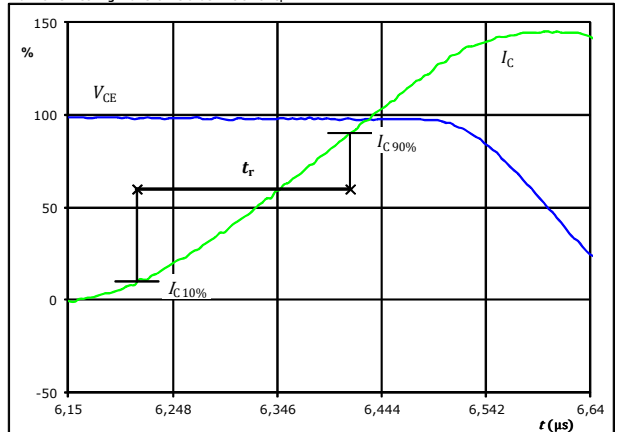

$V_C(100\%) =$	700	V
$I_C(100\%) =$	15	A
$t_r =$	0,200	µs



Vincotech

**10-FY12PMA025M7-P588A78**  
**10-PY12PMA025M7-P588A78Y**  
**10-F112PMA025M7-P588A79**  
**10-P112PMA025M7-P588A79Y**  
 datasheet

## Brake Switching Characteristics

figure 5. IGBT

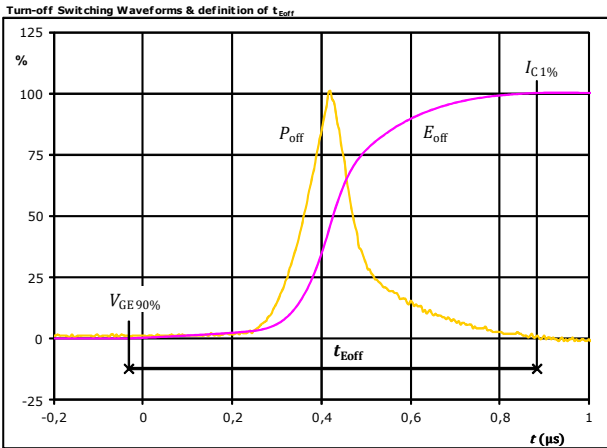

$P_{off}(100\%) = 10,55$  kW  
 $E_{off}(100\%) = 1,71$  mJ  
 $t_{Eoff} = 0,92$  µs

figure 6. IGBT

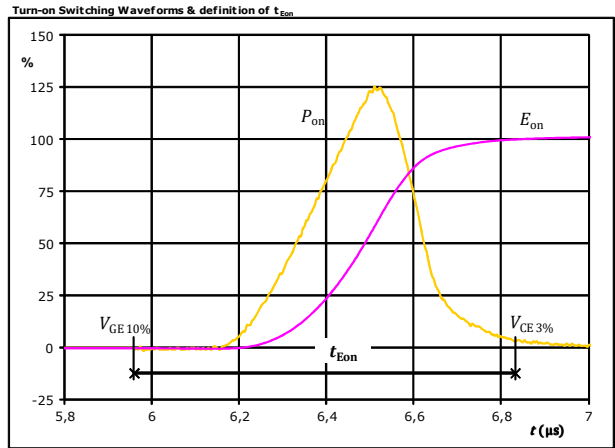

$P_{on}(100\%) = 10,55$  kW  
 $E_{on}(100\%) = 3,57$  mJ  
 $t_{Eon} = 0,87$  µs

figure 7. FWD

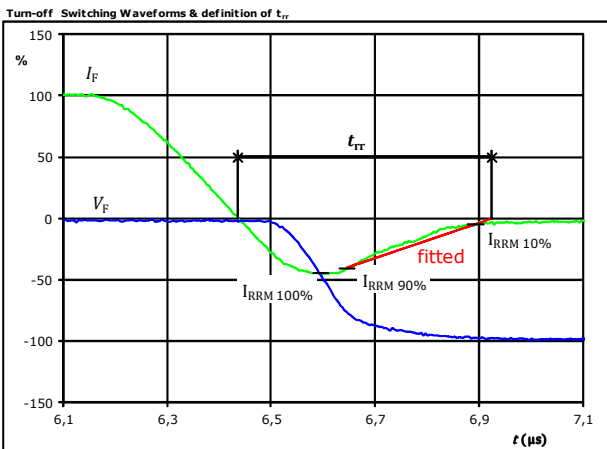

$V_F(100\%) = 700$  V  
 $I_F(100\%) = 15$  A  
 $I_{RRM}(100\%) = -7$  A  
 $t_{rr} = 0,485$  µs



Vincotech

**10-FY12PMA025M7-P588A78**  
**10-PY12PMA025M7-P588A78Y**  
**10-F112PMA025M7-P588A79**  
**10-P112PMA025M7-P588A79Y**  
 datasheet

## Brake Switching Characteristics

**figure 8.** FWD

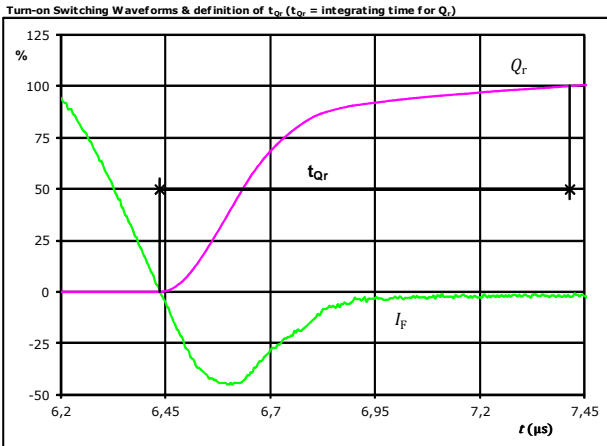

$I_F$  (100%) = 15 A  
 $Q_r$  (100%) = 1,88  $\mu$ C  
 $t_{Qr}$  = 0,98  $\mu$ s

**figure 9.** FWD

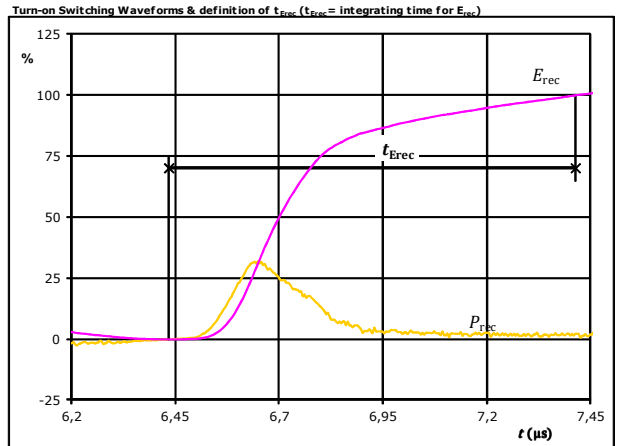

$P_{rec}$  (100%) = 10,55 kW  
 $E_{rec}$  (100%) = 0,78 mJ  
 $t_{Erec}$  = 0,98  $\mu$ s



Vincotech

**10-FY12PMA025M7-P588A78**  
**10-PY12PMA025M7-P588A78Y**  
**10-F112PMA025M7-P588A79**  
**10-P112PMA025M7-P588A79Y**  
 datasheet

Ordering Code & Marking						
Version			Ordering Code			
without thermal paste 12 mm housing with solder pins			10-FY12PMA025M7-P588A78			
with thermal paste 12 mm housing with solder pins			10-FY12PMA025M7-P588A78-/3/			
without thermal paste 12 mm housing with Press-fit pins			10-PY12PMA025M7-P588A78Y			
with thermal paste 12 mm housing with Press-fit pins			10-PY12PMA025M7-P588A78Y-/3/			
without thermal paste 17 mm housing with solder pins			10-F112PMA025M7-P588A79			
with thermal paste 17 mm housing with solder pins			10-F112PMA025M7-P588A79-/3/			
without thermal paste 17 mm housing with Press-fit pins			10-P112PMA025M7-P588A79Y			
with thermal paste 17 mm housing with Press-fit pins			10-P112PMA025M7-P588A79Y-/3/			

Text	Name		Date code	UL & VIN	Lot	Serial
	Type&Ver	Lot number	Serial	Date code		
NN-NNNNNNNNNNNN TTTTIV WWYY UL VIN LLLL SSSS	TTTTTIV	LLLLL	SSSS	WWYY	LLLLL	SSSS

Pin table			
Pin	X	Y	Function
1	52,55	0	G27
2	47,7	0	DC-Rect
3	44,8	0	DC-Rect
4	37,8	0	DC+Rect
5	37,8	2,8	DC+Rect
6	35	0	DC+Inv
7	35	2,8	DC+Inv
8	28	0	Therm1
9	25,2	0	Therm2
10	22,4	0	DC-3
11	19,6	0	G15
12	16,8	0	S15
13	14	0	DC-2
14	11,2	0	G13
15	8,4	0	S13
16	5,6	0	DC-1
17	2,8	0	G11
18	0	0	S11
19	0	28,5	Ph1
20	2,8	28,5	G12
21	7,5	28,5	S12
22	14,5	28,5	Ph2
23	17,3	28,5	G14
24	22	28,5	S14
25	29	28,5	Ph3
26	31,8	28,5	G16
27	36,5	28,5	S16
28	43,5	28,5	ACIn1
29	52,55	25	ACIn2
30	52,55	16,9	ACIn3
31	52,55	8,6	Br
32	52,55	2,8	DC-Br

P588A79Y

P588A79

P588A78Y

P588A78

Tolerance of pinpositions ±0,5mm at the end of pins  
Dimension of coordinate axis is only offset without tolerance



Vincotech

**10-FY12PMA025M7-P588A78**  
**10-PY12PMA025M7-P588A78Y**  
**10-F112PMA025M7-P588A79**  
**10-P112PMA025M7-P588A79Y**  
 datasheet

Pinout

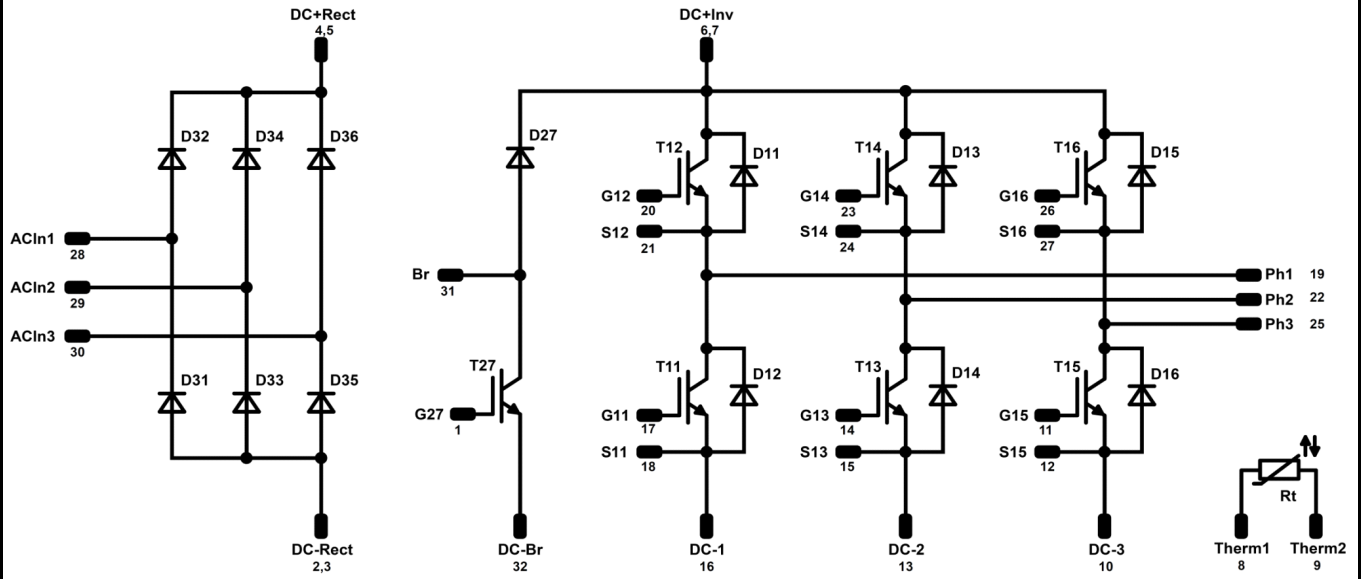

Identification

ID	Component	Voltage	Current	Function	Comment
D31, D32, D33, D34, D35, D36	Rectifier	1600 V	35 A	Rectifier Diode	
T11, T12, T13, T14, T15, T16	IGBT	1200 V	25 A	Inverter Switch	
D11, D12, D13, D14, D15, D16	FWD	1200 V	25 A	Inverter Diode	
T27	IGBT	1200 V	15 A	Brake Switch	
D27	FWD	1200 V	10 A	Brake Diode	
Rt	NTC			Thermistor	





Vincotech

**10-FY12PMA025M7-P588A78**  
**10-PY12PMA025M7-P588A78Y**  
**10-F112PMA025M7-P588A79**  
**10-P112PMA025M7-P588A79Y**  
datasheet

Packaging instruction			
Standard packaging quantity (SPQ) 100	>SPQ	Standard	<SPQ Sample

Handling instruction
Handling instructions for <i>flow</i> 1 packages see vincotech.com website.

Package data
Package data for <i>flow</i> 1 packages see vincotech.com website.

UL recognition and file number
This device is certified according to UL 1557 standard, UL file number E192116. For more information see vincotech.com website. 

Document No.:	Date:	Modification:	Pages
10-xx12PMA025M7-P588A7xx-D3-14	10 Jan. 2019	Added 17 mm press-fit pin variant Added short circuit rating to switches	1,3,31 2,11,14

**DISCLAIMER**

The information, specifications, procedures, methods and recommendations herein (together "information") are presented by Vincotech to reader in good faith, are believed to be accurate and reliable, but may well be incomplete and/or not applicable to all conditions or situations that may exist or occur. Vincotech reserves the right to make any changes without further notice to any products to improve reliability, function or design. No representation, guarantee or warranty is made to reader as to the accuracy, reliability or completeness of said information or that the application or use of any of the same will avoid hazards, accidents, losses, damages or injury of any kind to persons or property or that the same will not infringe third parties rights or give desired results. It is reader's sole responsibility to test and determine the suitability of the information and the product for reader's intended use.

**LIFE SUPPORT POLICY**

Vincotech products are not authorised for use as critical components in life support devices or systems without the express written approval of Vincotech.

As used herein:

1. Life support devices or systems are devices or systems which, (a) are intended for surgical implant into the body, or (b) support or sustain life, or (c) whose failure to perform when properly used in accordance with instructions for use provided in labelling can be reasonably expected to result in significant injury to the user.
2. A critical component is any component of a life support device or system whose failure to perform can be reasonably expected to cause the failure of the life support device or system, or to affect its safety or effectiveness.