



flow3xMNPC 1

1200 V / 15 A

Topology features

- Three-phase Mixed Voltage Neutral Point Clamped Topology (T-Type)
- Kelvin Emitter for improved switching performance
- Temperature sensor

Component features

- Easy paralleling
- High speed switching
- Low switching losses

Housing features

- Base isolation: Al₂O₃
- Convex shaped substrate for superior thermal contact
- Thermo-mechanical push-and-pull force relief
- Press-fit pin
- Reliable cold welding connection

Target applications

- Solar Inverters
- UPS

Types

- 10-PY12M3A015SH01-M743F68Y

flow 1 12 mm housing

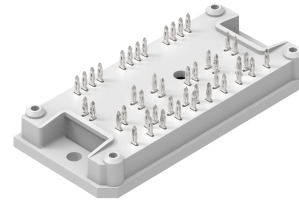

Schematic

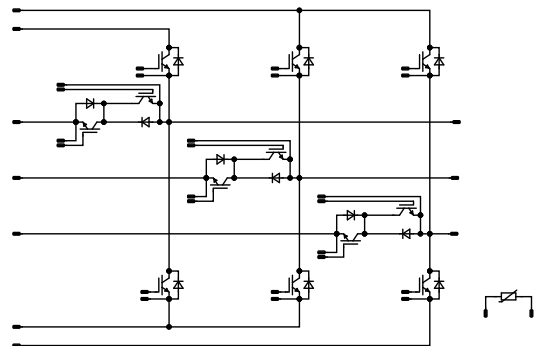



Vincotech

Maximum Ratings

$T_j = 25\text{ °C}$, unless otherwise specified

Parameter	Symbol	Conditions	Value	Unit
Buck Switch				
Collector-emitter voltage	V_{CES}		1200	V
Collector current (DC current)	I_C	$T_j = T_{jmax}$ $T_s = 80\text{ °C}$	21	A
Repetitive peak collector current	I_{CRM}	t_p limited by T_{jmax}	45	A
Turn off safe operating area		$T_j = 150\text{ °C}$, $V_{CE} = 1200\text{ V}$	60	A
Total power dissipation	P_{tot}	$T_j = T_{jmax}$ $T_s = 80\text{ °C}$	61	W
Gate-emitter voltage	V_{GES}		± 20	V
Short circuit ratings	t_{SC}	$V_{GE} = 15\text{ V}$, $V_{CC} = 800\text{ V}$ $T_j = 150\text{ °C}$	10	μs
Maximum junction temperature	T_{jmax}		175	$^{\circ}\text{C}$

Buck Diode

Peak repetitive reverse voltage	V_{RRM}		650	V
Forward current (DC current)	I_F	$T_j = T_{jmax}$ $T_s = 80\text{ °C}$	25	A
Repetitive peak forward current	I_{FRM}	t_p limited by T_{jmax}	30	A
Total power dissipation	P_{tot}	$T_j = T_{jmax}$ $T_s = 80\text{ °C}$	43	W
Maximum junction temperature	T_{jmax}		175	$^{\circ}\text{C}$

Boost Switch

Collector-emitter voltage	V_{CES}		600	V
Collector current (DC current)	I_C	$T_j = T_{jmax}$ $T_s = 80\text{ °C}$	22	A
Repetitive peak collector current	I_{CRM}	t_p limited by T_{jmax}	45	A
Total power dissipation	P_{tot}	$T_j = T_{jmax}$ $T_s = 80\text{ °C}$	52	W
Gate-emitter voltage	V_{GES}		± 20	V
Short circuit ratings	t_{SC}	$V_{GE} = 15\text{ V}$, $V_{CC} = 360\text{ V}$ $T_j = 150\text{ °C}$	6	μs
Maximum junction temperature	T_{jmax}		175	$^{\circ}\text{C}$



Vincotech

Maximum Ratings

$T_j = 25\text{ °C}$, unless otherwise specified

Parameter	Symbol	Conditions	Value	Unit
Boost Diode				
Peak repetitive reverse voltage	V_{RRM}		1200	V
Forward current (DC current)	I_F	$T_j = T_{jmax}$ $T_s = 80\text{ °C}$	16	A
Surge (non-repetitive) forward current	I_{FSM}	Single Half Sine Wave, $t_p = 10\text{ ms}$ $T_j = 25\text{ °C}$	65	A
Surge current capability	I^2t		21	A ² s
Total power dissipation	P_{tot}	$T_j = T_{jmax}$ $T_s = 80\text{ °C}$	42	W
Maximum junction temperature	T_{jmax}		175	°C

Module Properties

Thermal Properties

Storage temperature	T_{stg}		-40...+125	°C
Operation temperature under switching condition	T_{jop}		-40...+($T_{jmax} - 25$)	°C

Isolation Properties

Isolation voltage	V_{isol}	DC Test Voltage* $t_p = 2\text{ s}$	6000	V
Isolation voltage	V_{isol}	AC Voltage $t_p = 1\text{ min}$	2500	V
Creepage distance			>12,7	mm
Clearance			7,89	mm
Comparative Tracking Index	CTI		≥ 200	

*100 % tested in production



Vincotech

Characteristic Values

Parameter	Symbol	Conditions					Values			Unit
		V_{GS} [V]	V_{GE} [V]	V_{DS} [V]	I_C [A]	T_j [°C]	Min	Typ	Max	

Buck Switch

Static

Gate-emitter threshold voltage	$V_{GE(th)}$	$V_{CE} = V_{GE}$			0,0005	25	5,3	5,8	6,3	V
Collector-emitter saturation voltage	$V_{CE(sat)}$		15		15	25 150	1,78	1,91 2,29	2,42 ⁽¹⁾	V
Collector-emitter cut-off current	I_{CES}		0	1200		25			2	μA
Gate-emitter leakage current	I_{GES}		20	0		25			120	nA
Internal gate resistance	r_g							None		Ω
Input capacitance	C_{ies}							875		pF
Output capacitance	C_{oes}	$f = 1$ Mhz	0	25		25		75		pF
Reverse transfer capacitance	C_{res}							45		pF
Gate charge	Q_g	$V_{CC} = 960$ V	15		15	25		75		nC

Thermal

Thermal resistance junction to sink ⁽²⁾	$R_{th(j-s)}$	$\lambda_{paste} = 3,4$ W/mK (PSX)						1,55		K/W
--	---------------	---------------------------------------	--	--	--	--	--	------	--	-----

Dynamic

Turn-on delay time	$t_{d(on)}$					25 125 150		98,28 97,33 97,58		ns
Rise time	t_r					25 125 150		23,43 27,94 28,47		ns
Turn-off delay time	$t_{d(off)}$					25 125 150		148,05 187,59 196,17		ns
Fall time	t_f					25 125 150		40,42 66,85 73,46		ns
Turn-on energy (per pulse)	E_{on}	$Q_{tFWD} = 0,401$ μC $Q_{tFWD} = 0,813$ μC $Q_{tFWD} = 0,926$ μC				25 125 150		0,42 0,615 0,679		mWs
Turn-off energy (per pulse)	E_{off}					25 125 150		0,411 0,631 0,683		mWs



Vincotech

10-PY12M3A015SH01-M743F68Y
datasheet

Characteristic Values

Parameter	Symbol	Conditions					Values			Unit
		V_{GE} [V] V_{GS} [V]	V_{CE} [V] V_{DS} [V] V_F [V]	I_C [A] I_D [A] I_F [A]	T_j [°C]	Min	Typ	Max		
Buck Diode										
Static										
Forward voltage	V_F			15	25 125 150		1,51 1,43 1,39	1,92 ⁽¹⁾		V
Reverse leakage current	I_R	$V_r = 650$ V			25			0,94		μA
Thermal										
Thermal resistance junction to sink ⁽²⁾	$R_{th(j-s)}$	$\lambda_{paste} = 3,4$ W/mK (PSX)					2,23			K/W
Dynamic										
Peak recovery current	I_{RM}				25 125 150		6,96 9,32 9,78			A
Reverse recovery time	t_{rr}				25 125 150		96,37 141,3 156,82			ns
Recovered charge	Q_r	$di/dt=634$ A/μs $di/dt=567$ A/μs $di/dt=532$ A/μs	±15	350	15	25 125 150	0,401 0,813 0,926			μC
Reverse recovered energy	E_{rec}				25 125 150		0,065 0,139 0,161			mWs
Peak rate of fall of recovery current	$(di_r/dt)_{max}$				25 125 150		171,02 114,03 91,93			A/μs



Vincotech

Characteristic Values

Parameter	Symbol	Conditions					Values			Unit
		V_{GE} [V] V_{GS} [V]	V_{CE} [V] V_{DS} [V] V_F [V]	I_C [A] I_D [A] I_F [A]	T_j [°C]	Min	Typ	Max		

Boost Switch

Static

Gate-emitter threshold voltage	$V_{GE(th)}$	$V_{CE} = V_{GE}$			0,00021	25	5	5,8	6,5	V
Collector-emitter saturation voltage	$V_{CE(sat)}$		15		15	25 150	1,1	1,6 1,85	1,9 ⁽¹⁾	V
Collector-emitter cut-off current	I_{CES}		0	600		25			0,85	μA
Gate-emitter leakage current	I_{GES}		20	0		25			300	nA
Internal gate resistance	r_g							None		Ω
Input capacitance	C_{ies}							800		pF
Output capacitance	C_{oes}	$f = 1$ Mhz	0	25		25		55		pF
Reverse transfer capacitance	C_{res}							24		pF
Gate charge	Q_g		0/15		0	25		87		nC

Thermal

Thermal resistance junction to sink ⁽²⁾	$R_{th(j-s)}$	$\lambda_{paste} = 3,4$ W/mK (PSX)						1,83		K/W
--	---------------	---------------------------------------	--	--	--	--	--	------	--	-----

Dynamic

Turn-on delay time	$t_{d(on)}$					25 125 150		115,11 113,74 113,26		ns
Rise time	t_r					25 125 150		23,13 26,68 27,32		ns
Turn-off delay time	$t_{d(off)}$					25 125 150		152,66 174,48 179,22		ns
Fall time	t_f					25 125 150		56,26 86,61 95,07		ns
Turn-on energy (per pulse)	E_{on}	$Q_{tFWD} = 0,413$ μC $Q_{tFWD} = 0,916$ μC $Q_{tFWD} = 1,1$ μC				25 125 150		0,5 0,626 0,687		mWs
Turn-off energy (per pulse)	E_{off}					25 125 150		0,415 0,568 0,607		mWs



Vincotech

10-PY12M3A015SH01-M743F68Y
datasheet

Characteristic Values

Parameter	Symbol	Conditions					Values			Unit
		V_{GE} [V] V_{GS} [V]	V_{CE} [V] V_{DS} [V] V_F [V]	I_C [A] I_D [A] I_F [A]	T_j [°C]	Min	Typ	Max		
Boost Diode										
Static										
Forward voltage	V_F				15	25 125 150		2,37 2,47	2,71 ⁽¹⁾ 2,77 ⁽¹⁾	V
Reverse leakage current	I_R	$V_r = 1200$ V				25 150		900	60 1800	μA
Thermal										
Thermal resistance junction to sink ⁽²⁾	$R_{th(j-s)}$	$\lambda_{paste} = 3,4$ W/mK (PSX)						2,24		K/W
Dynamic										
Peak recovery current	I_{RM}					25 125 150		11,29 13,69 14,71		A
Reverse recovery time	t_{rr}					25 125 150		132,03 245,19 266,33		ns
Recovered charge	Q_r	$di/dt=826$ A/μs $di/dt=730$ A/μs $di/dt=728$ A/μs	±15	350	15	25 125 150		0,413 0,916 1,1		μC
Reverse recovered energy	E_{rec}					25 125 150		0,054 0,165 0,2		mWs
Peak rate of fall of recovery current	$(di_r/dt)_{max}$					25 125 150		540,08 353,19 330,25		A/μs



Vincotech

Characteristic Values

Parameter	Symbol	Conditions					Values			Unit
		V_{GS} [V]	V_{GE} [V]	V_{DS} [V]	V_{CE} [V]	I_D [A]	I_C [A]	T_j [°C]	Min	

Thermistor

Static

Rated resistance	R					25		22		kΩ
Deviation of R_{100}	$A_{R/R}$	$R_{100} = 1484 \Omega$				100	-5		5	%
Power dissipation	P					25		130		mW
Power dissipation constant	d					25		1,5		mW/K
B-value	$B_{(25/50)}$	Tol. $\pm 1 \%$						3962		K
B-value	$B_{(25/100)}$	Tol. $\pm 1 \%$						4000		K
Vincotech Thermistor Reference									I	

⁽¹⁾ Value at chip level

⁽²⁾ Only valid with pre-applied Vincotech thermal interface material.



Buck Switch Characteristics

figure 1. IGBT

Typical output characteristics

$$I_C = f(V_{CE})$$

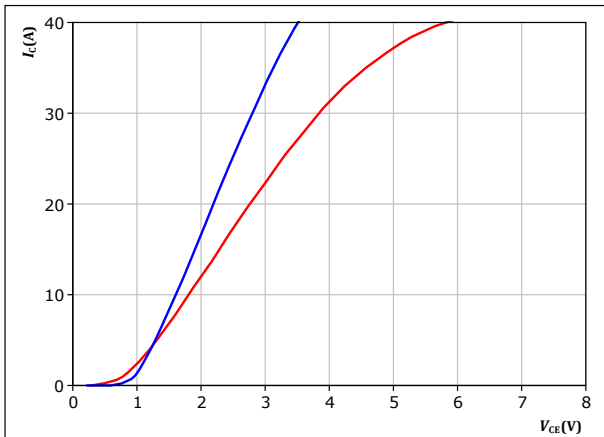

$t_p = 250 \mu s$
 $V_{GE} = 15 V$
 $T_j: 25^\circ C$ (blue), $150^\circ C$ (red)

figure 2. IGBT

Typical output characteristics

$$I_C = f(V_{CE})$$

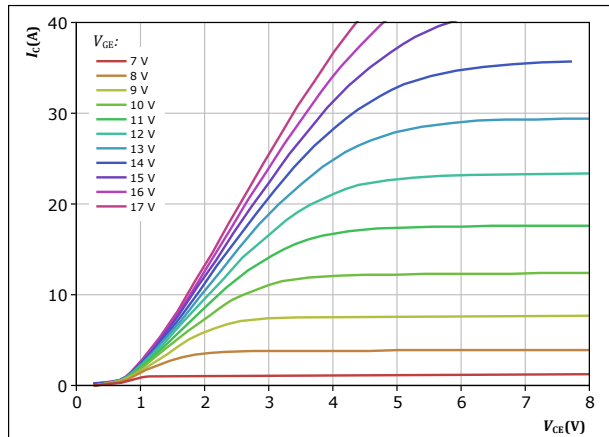

$t_p = 250 \mu s$
 $T_j = 150^\circ C$
 V_{GE} from 7 V to 17 V in steps of 1 V

figure 3. IGBT

Typical transfer characteristics

$$I_C = f(V_{GE})$$

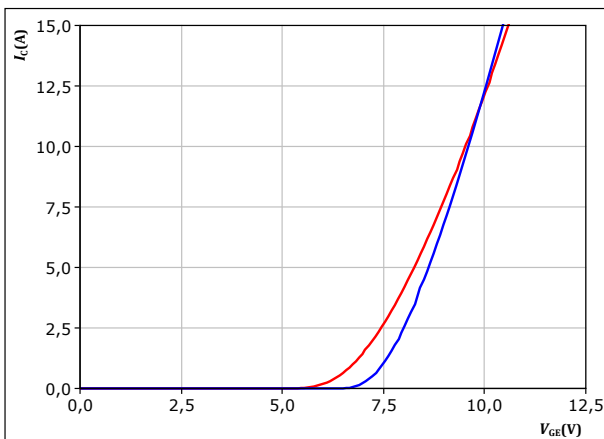

$t_p = 250 \mu s$
 $V_{CE} = 10 V$
 $T_j: 25^\circ C$ (blue), $150^\circ C$ (red)

figure 4. IGBT

Transient thermal impedance as a function of pulse width

$$Z_{th(j-s)} = f(t_p)$$

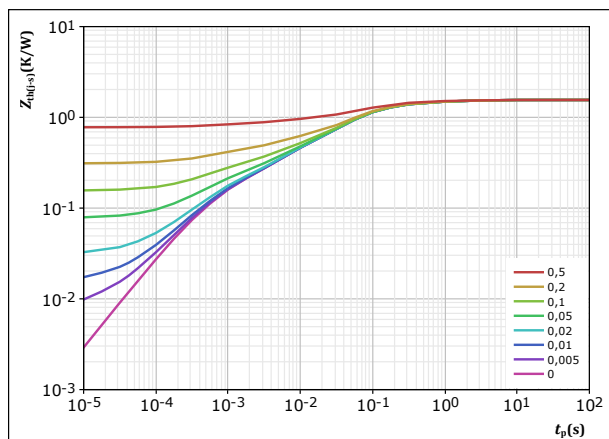

$D = t_p / T$
 $R_{th(j-s)} = 1,554 K/W$
IGBT thermal model values

R (K/W)	τ (s)
1,01E-01	1,83E+00
2,80E-01	2,37E-01
8,28E-01	5,47E-02
2,19E-01	5,24E-03
1,25E-01	5,32E-04



Vincotech

Buck Switch Characteristics

figure 5. IGBT

Safe operating area

$$I_C = f(V_{CE})$$

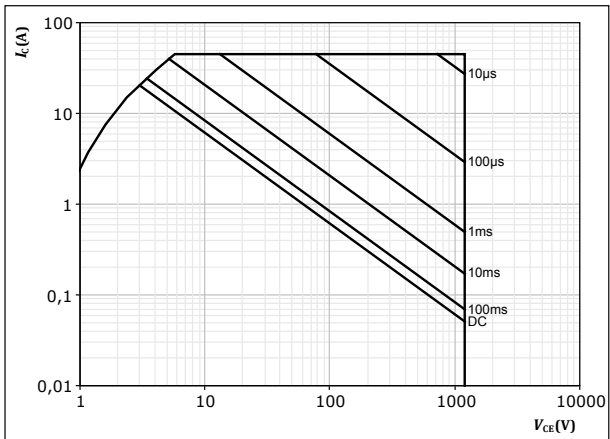

$D =$ single pulse

$T_s = 80$ °C

$V_{GE} = 15$ V

$T_j = T_{jmax}$



Buck Diode Characteristics

figure 6. FWD

Typical forward characteristics

$$I_F = f(V_F)$$

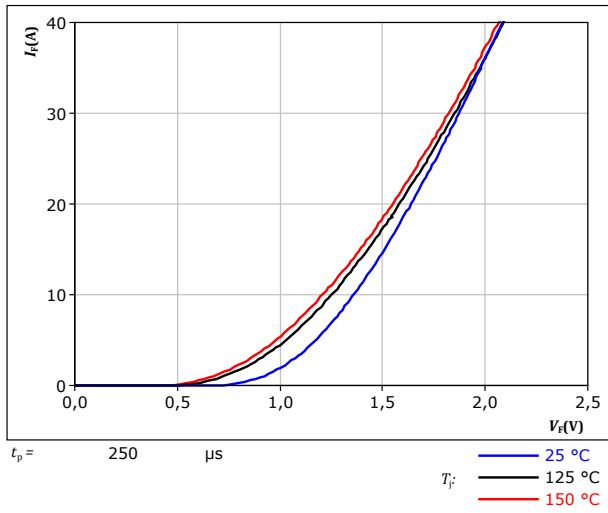
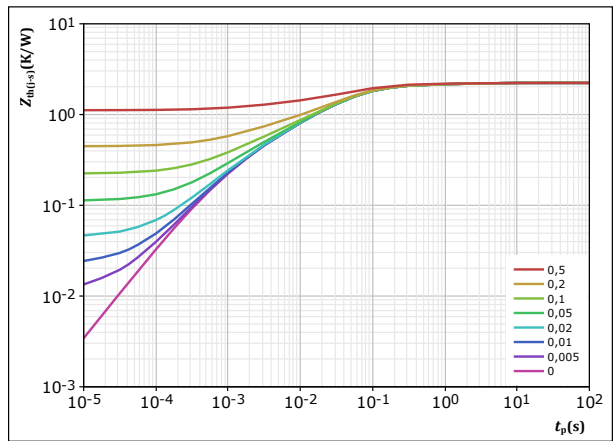

figure 7. FWD

Transient thermal impedance as a function of pulse width

$$Z_{th(j-s)} = f(t_p)$$



$D = t_p / T$
 $R_{th(j-s)} = 2,232$ K/W
 FWD thermal model values

R (K/W)	τ (s)
1,05E-01	2,52E+00
2,43E-01	2,26E-01
1,06E+00	5,21E-02
4,77E-01	1,22E-02
2,72E-01	2,29E-03
7,91E-02	4,79E-04



Boost Switch Characteristics

figure 8. IGBT

Typical output characteristics
 $I_C = f(V_{CE})$

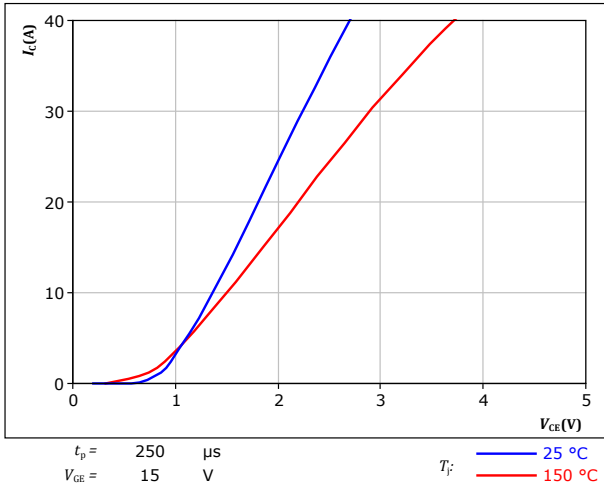

figure 9. IGBT

Typical output characteristics
 $I_C = f(V_{CE})$

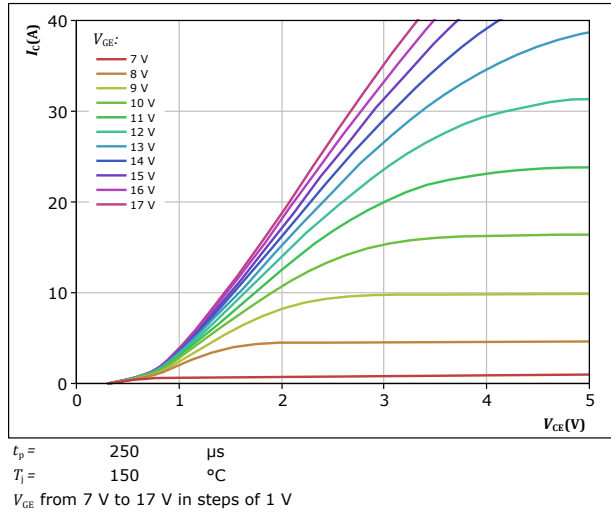

figure 10. IGBT

Typical transfer characteristics
 $I_C = f(V_{GE})$

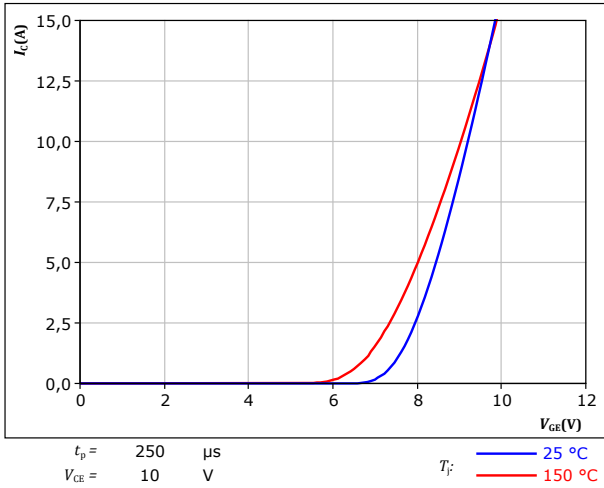
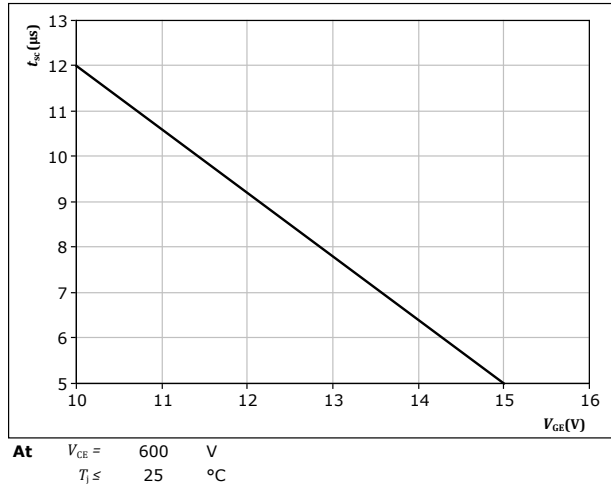

figure 11. IGBT

Short circuit withstand time as a function of V_{GE}
 $t_{sc} = f(V_{GE})$





Boost Switch Characteristics

figure 12. IGBT

Typical short circuit current as a function of V_{GE}
 $I_{SC} = f(V_{GE})$



At $V_{CE} = 400$ V
 $T_j \leq 150$ °C

figure 13. IGBT

Transient thermal impedance as a function of pulse width
 $Z_{th(j-s)} = f(t_p)$

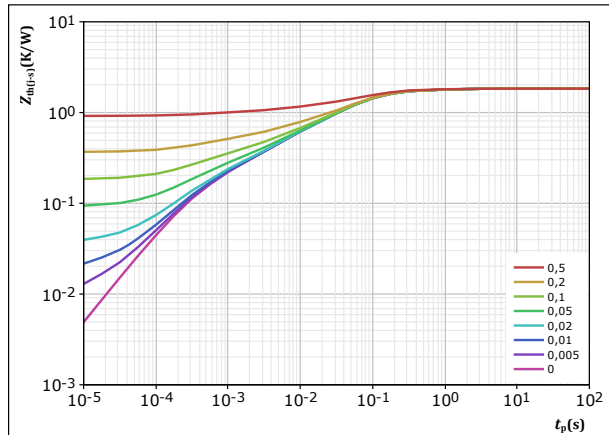

$D = t_p / T$
 $R_{th(j-s)} = 1,834$ K/W
IGBT thermal model values

R (K/W)	τ (s)
8,30E-02	1,29E+00
3,76E-01	1,56E-01
8,46E-01	5,15E-02
2,81E-01	8,16E-03
1,16E-01	2,04E-03
1,32E-01	3,43E-04

figure 14. IGBT

Safe operating area
 $I_C = f(V_{CE})$

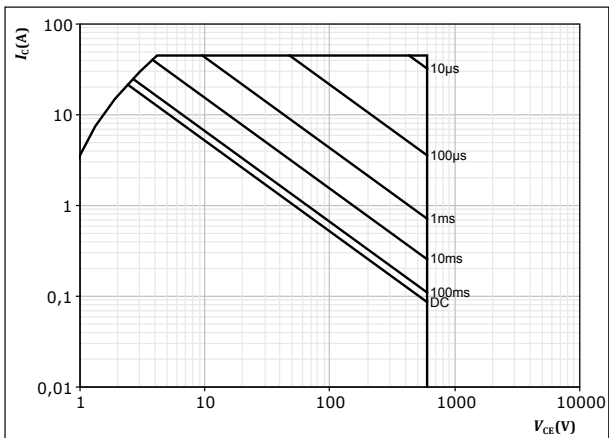

$D = \text{single pulse}$
 $T_j = 80$ °C
 $V_{GE} = 15$ V
 $T_j = T_{jmax}$

figure 15. IGBT

Gate voltage vs gate charge
 $V_{GE} = f(Q_g)$

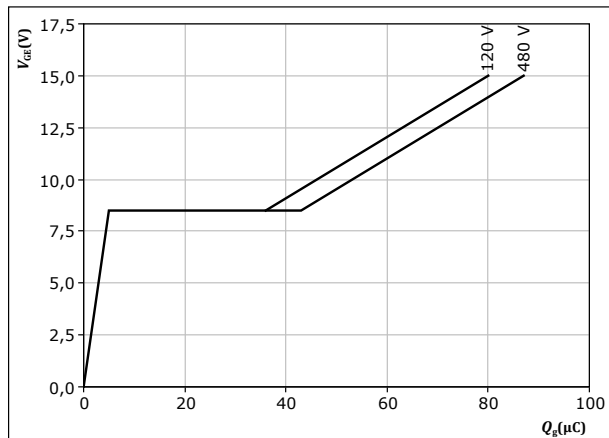

$I_C = 15$ A
 $T_j = 25$ °C



Boost Diode Characteristics

figure 16. FWD

Typical forward characteristics

$$I_F = f(V_F)$$

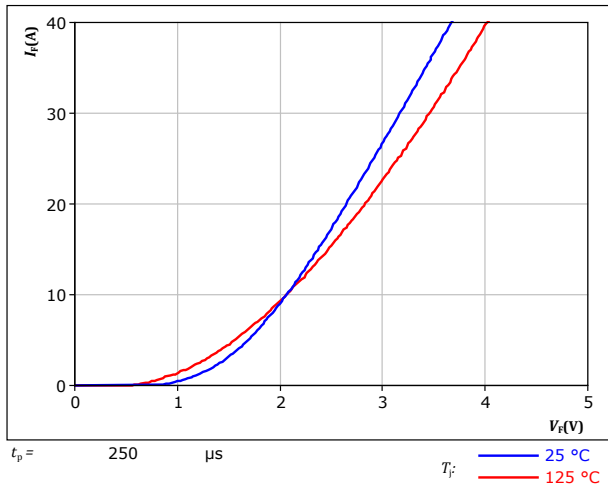
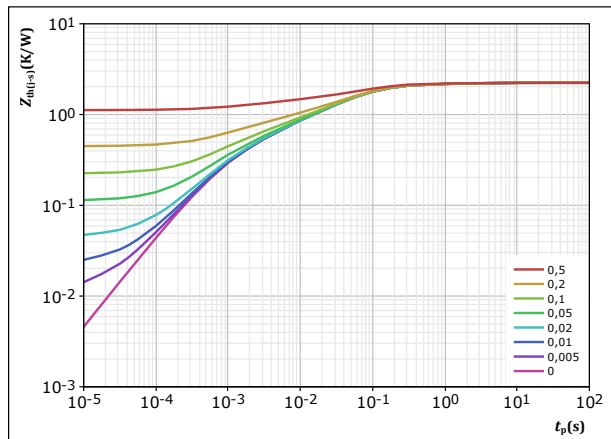

figure 17. FWD

Transient thermal impedance as a function of pulse width

$$Z_{th(j-s)} = f(t_p)$$



$D = t_p / T$

$R_{th(j-s)} = 2,237 \text{ K/W}$

FWD thermal model values

$R \text{ (K/W)}$	$\tau \text{ (s)}$
7,47E-02	2,62E+00
1,66E-01	3,82E-01
9,90E-01	7,20E-02
4,45E-01	1,82E-02
3,36E-01	3,41E-03
2,26E-01	6,98E-04



Thermistor Characteristics

figure 18. Thermistor

Typical NTC characteristic as function of temperature

$$R_T = f(T)$$

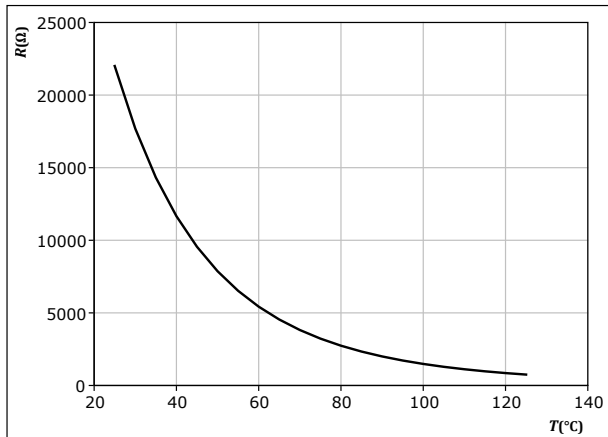



Buck Switching Characteristics

figure 19. IGBT

Typical switching energy losses as a function of collector current
 $E = f(I_c)$

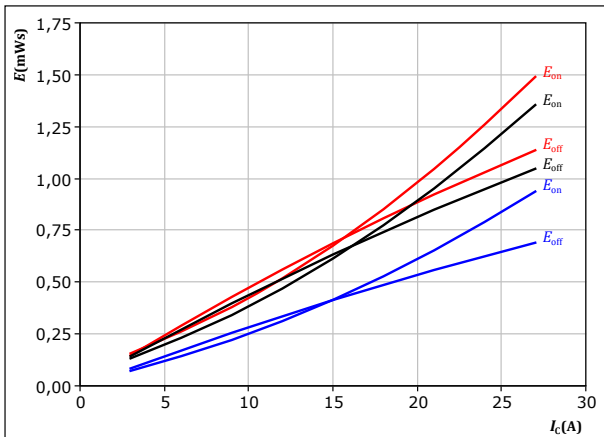

With an inductive load at
 $V_{CE} = 350 \text{ V}$
 $V_{GE} = \pm 15 \text{ V}$
 $R_{gon} = 32 \ \Omega$
 $R_{goff} = 32 \ \Omega$

T_j :
— 25 °C
— 125 °C
— 150 °C

figure 20. IGBT

Typical switching energy losses as a function of IGBT turn on gate resistor
 $E = f(R_g)$

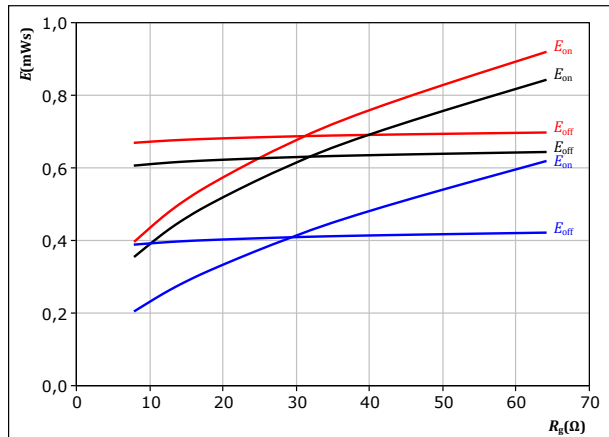

With an inductive load at
 $V_{CE} = 350 \text{ V}$
 $V_{GE} = \pm 15 \text{ V}$
 $I_c = 15 \text{ A}$

T_j :
— 25 °C
— 125 °C
— 150 °C

figure 21. FWD

Typical reverse recovered energy loss as a function of collector current
 $E_{rec} = f(I_c)$

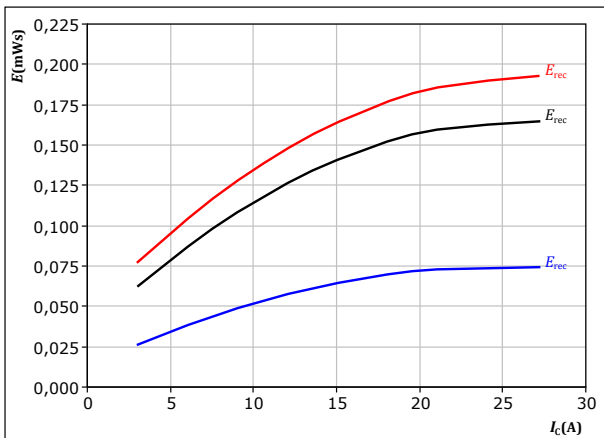

With an inductive load at
 $V_{CE} = 350 \text{ V}$
 $V_{GE} = \pm 15 \text{ V}$
 $R_{gon} = 32 \ \Omega$

T_j :
— 25 °C
— 125 °C
— 150 °C

figure 22. FWD

Typical reverse recovered energy loss as a function of IGBT turn on gate resistor
 $E_{rec} = f(R_g)$

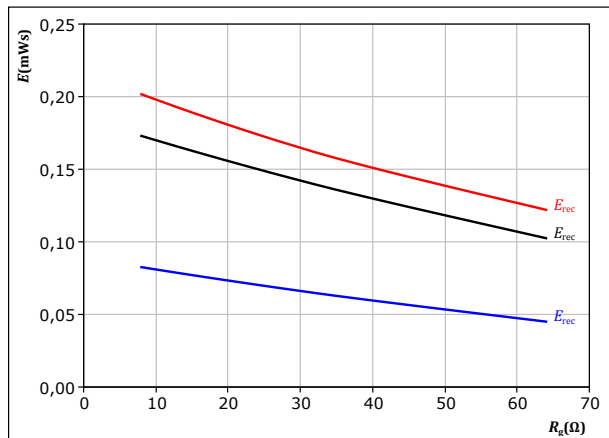

With an inductive load at
 $V_{CE} = 350 \text{ V}$
 $V_{GE} = \pm 15 \text{ V}$
 $I_c = 15 \text{ A}$

T_j :
— 25 °C
— 125 °C
— 150 °C



Buck Switching Characteristics

figure 23. IGBT

Typical switching times as a function of collector current
 $t = f(I_c)$

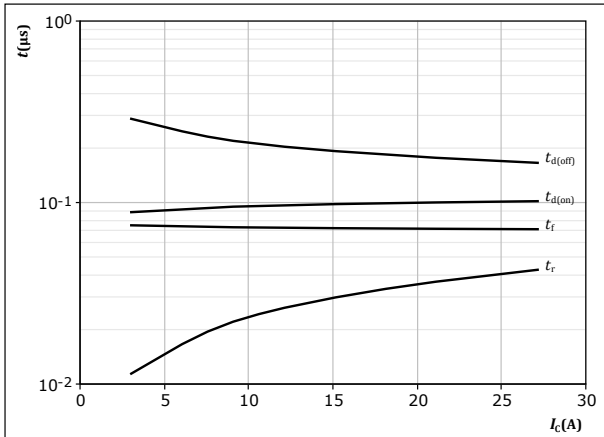

With an inductive load at
 $T_j = 150 \text{ }^\circ\text{C}$
 $V_{CE} = 350 \text{ V}$
 $V_{GE} = \pm 15 \text{ V}$
 $R_{gon} = 32 \text{ } \Omega$
 $R_{goff} = 32 \text{ } \Omega$

figure 24. IGBT

Typical switching times as a function of IGBT turn on gate resistor
 $t = f(R_g)$

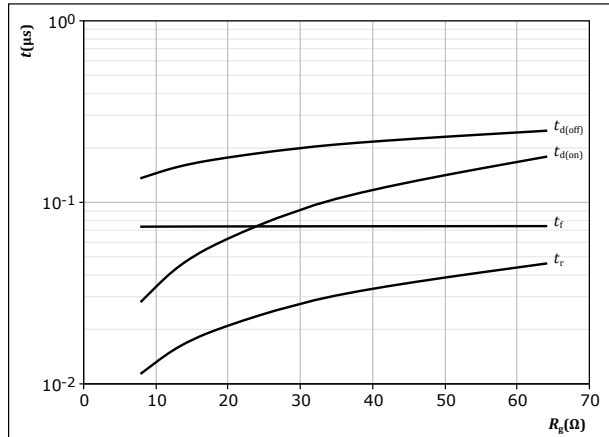

With an inductive load at
 $T_j = 150 \text{ }^\circ\text{C}$
 $V_{CE} = 350 \text{ V}$
 $V_{GE} = \pm 15 \text{ V}$
 $I_c = 15 \text{ A}$

figure 25. FWD

Typical reverse recovery time as a function of collector current
 $t_{rr} = f(I_c)$

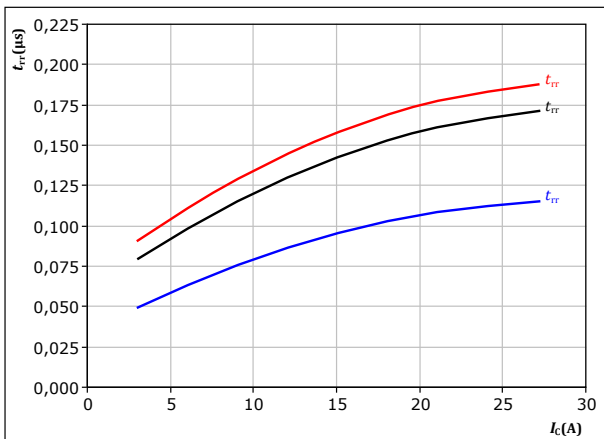

With an inductive load at
 $V_{CE} = 350 \text{ V}$
 $V_{GE} = \pm 15 \text{ V}$
 $R_{gon} = 32 \text{ } \Omega$
 $T_j:$ — 25 °C
— 125 °C
— 150 °C

figure 26. FWD

Typical reverse recovery time as a function of IGBT turn on gate resistor
 $t_{rr} = f(R_{gon})$

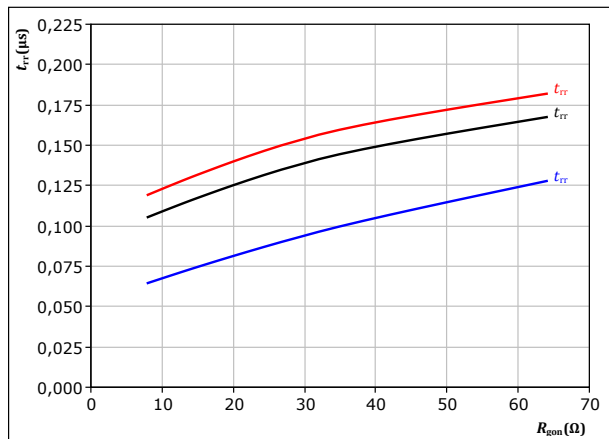

With an inductive load at
 $V_{CE} = 350 \text{ V}$
 $V_{GE} = \pm 15 \text{ V}$
 $I_c = 15 \text{ A}$
 $T_j:$ — 25 °C
— 125 °C
— 150 °C



Buck Switching Characteristics

figure 27. FWD

Typical recovered charge as a function of collector current
 $Q_r = f(I_c)$

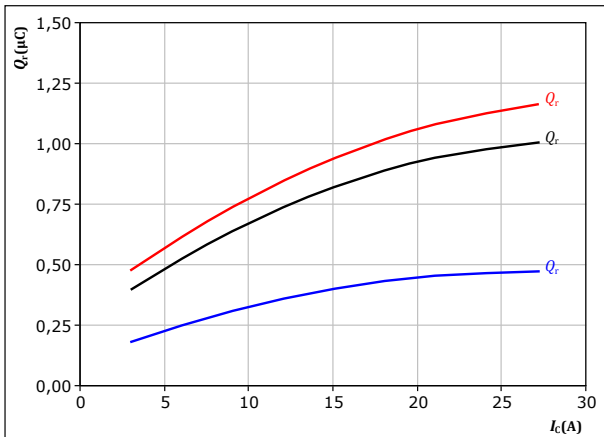

With an inductive load at
 $V_{CE} = 350$ V
 $V_{GE} = \pm 15$ V
 $R_{gon} = 32$ Ω
 T_j : 25 °C (blue), 125 °C (black), 150 °C (red)

figure 28. FWD

Typical recovered charge as a function of IGBT turn on gate resistor
 $Q_r = f(R_{gon})$

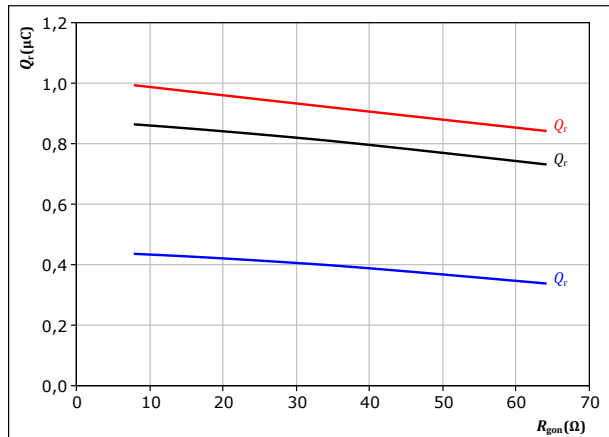

With an inductive load at
 $V_{CE} = 350$ V
 $V_{GE} = \pm 15$ V
 $I_c = 15$ A
 T_j : 25 °C (blue), 125 °C (black), 150 °C (red)

figure 29. FWD

Typical peak reverse recovery current as a function of collector current
 $I_{RM} = f(I_c)$

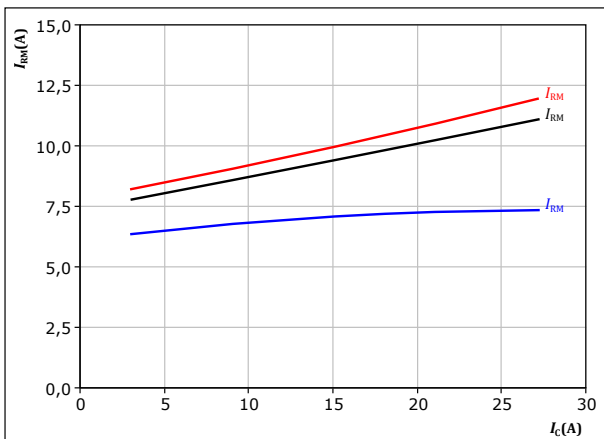

With an inductive load at
 $V_{CE} = 350$ V
 $V_{GE} = \pm 15$ V
 $R_{gon} = 32$ Ω
 T_j : 25 °C (blue), 125 °C (black), 150 °C (red)

figure 30. FWD

Typical peak reverse recovery current as a function of IGBT turn on gate resistor
 $I_{RM} = f(R_{gon})$

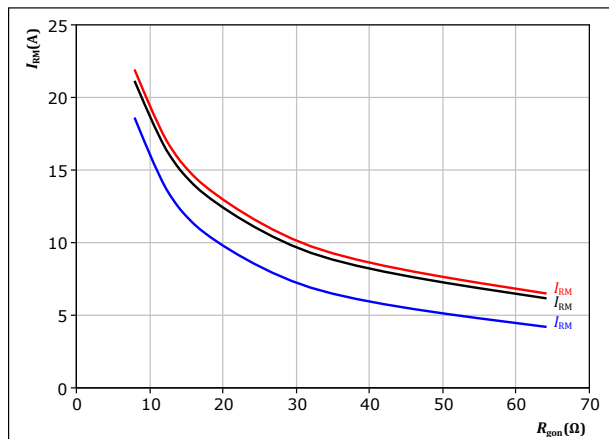

With an inductive load at
 $V_{CE} = 350$ V
 $V_{GE} = \pm 15$ V
 $I_c = 15$ A
 T_j : 25 °C (blue), 125 °C (black), 150 °C (red)



Buck Switching Characteristics

figure 31. FWD

Typical rate of fall of forward and reverse recovery current as a function of collector current
 $di_f/dt, di_r/dt = f(I_C)$

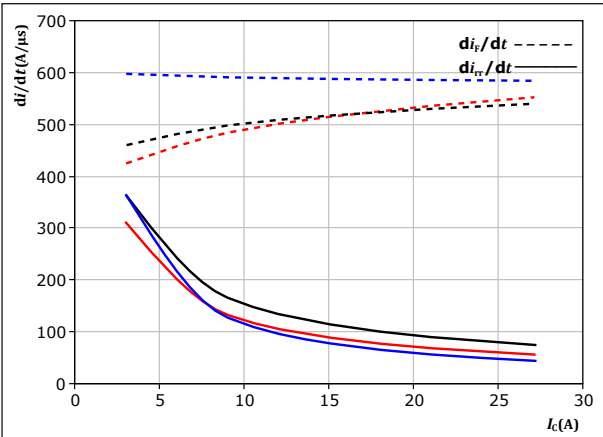

With an inductive load at

$V_{CE} = 350 \text{ V}$
 $V_{GE} = \pm 15 \text{ V}$
 $R_{gon} = 32 \text{ } \Omega$

$T_j:$ — 25 °C
 — 125 °C
 — 150 °C

figure 32. FWD

Typical rate of fall of forward and reverse recovery current as a function of turn on gate resistor
 $di_f/dt, di_r/dt = f(R_{gon})$

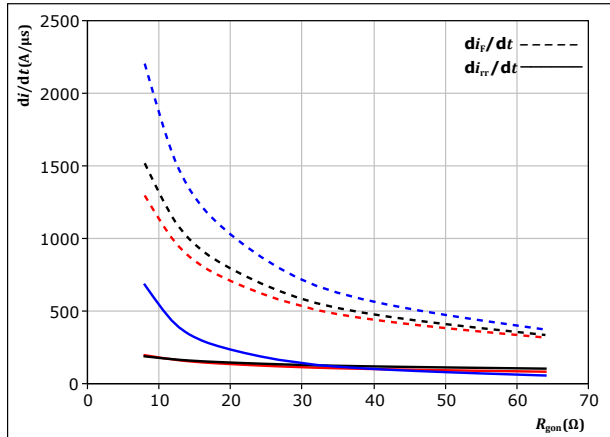

With an inductive load at

$V_{CE} = 350 \text{ V}$
 $V_{GE} = \pm 15 \text{ V}$
 $I_C = 15 \text{ A}$

$T_j:$ — 25 °C
 — 125 °C
 — 150 °C

figure 33. IGBT

Reverse bias safe operating area

$I_C = f(V_{CE})$

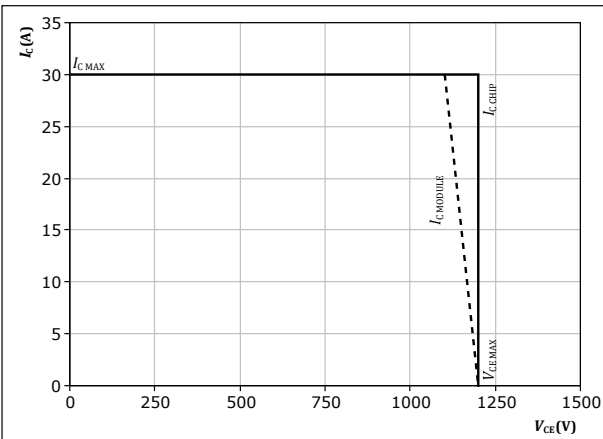

At $T_j = 150 \text{ } ^\circ\text{C}$
 $R_{gon} = 32 \text{ } \Omega$
 $R_{goff} = 32 \text{ } \Omega$



Boost Switching Characteristics

figure 34. IGBT

Typical switching energy losses as a function of collector current
 $E = f(I_c)$

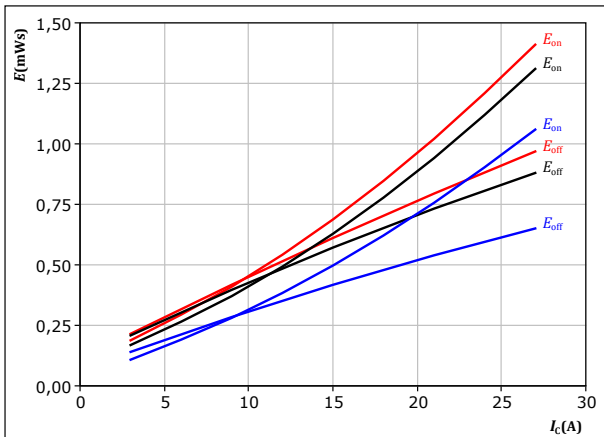

With an inductive load at

$V_{CE} =$	350	V	$T_j:$	— 25 °C
$V_{GE} =$	±15	V		— 125 °C
$R_{g(on)} =$	32	Ω		— 150 °C
$R_{g(off)} =$	32	Ω		

figure 35. IGBT

Typical switching energy losses as a function of IGBT turn on gate resistor
 $E = f(R_g)$

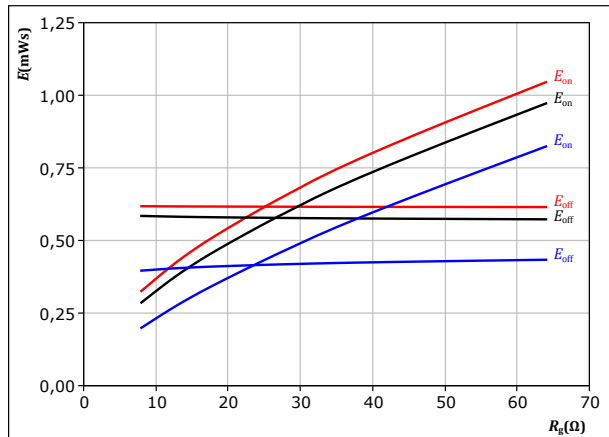

With an inductive load at

$V_{CE} =$	350	V	$T_j:$	— 25 °C
$V_{GE} =$	±15	V		— 125 °C
$I_c =$	15	A		— 150 °C

figure 36. FWD

Typical reverse recovered energy loss as a function of collector current
 $E_{rec} = f(I_c)$

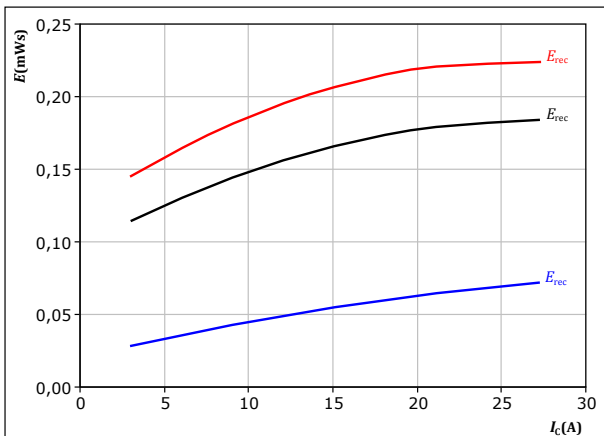

With an inductive load at

$V_{CE} =$	350	V	$T_j:$	— 25 °C
$V_{GE} =$	±15	V		— 125 °C
$R_{g(on)} =$	32	Ω		— 150 °C

figure 37. FWD

Typical reverse recovered energy loss as a function of IGBT turn on gate resistor
 $E_{rec} = f(R_g)$

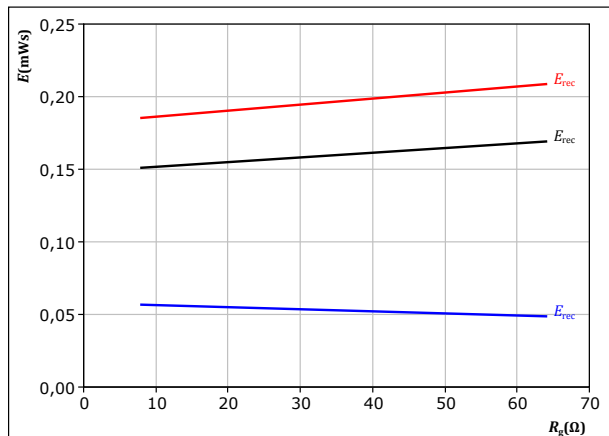

With an inductive load at

$V_{CE} =$	350	V	$T_j:$	— 25 °C
$V_{GE} =$	±15	V		— 125 °C
$I_c =$	15	A		— 150 °C



Boost Switching Characteristics

figure 38. IGBT

Typical switching times as a function of collector current
 $t = f(I_c)$

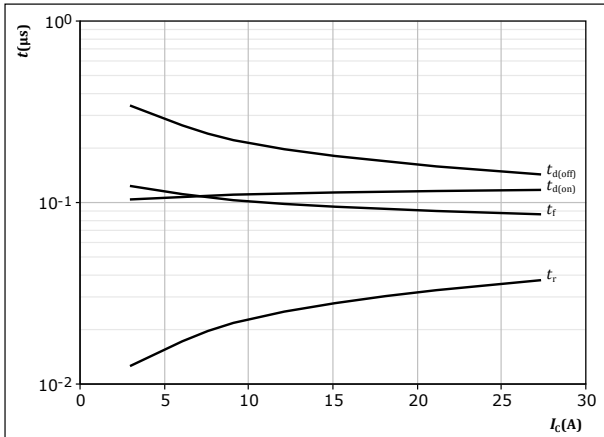

With an inductive load at
 $T_j = 150 \text{ }^\circ\text{C}$
 $V_{CE} = 350 \text{ V}$
 $V_{GE} = \pm 15 \text{ V}$
 $R_{gon} = 32 \text{ } \Omega$
 $R_{goff} = 32 \text{ } \Omega$

figure 39. IGBT

Typical switching times as a function of IGBT turn on gate resistor
 $t = f(R_g)$

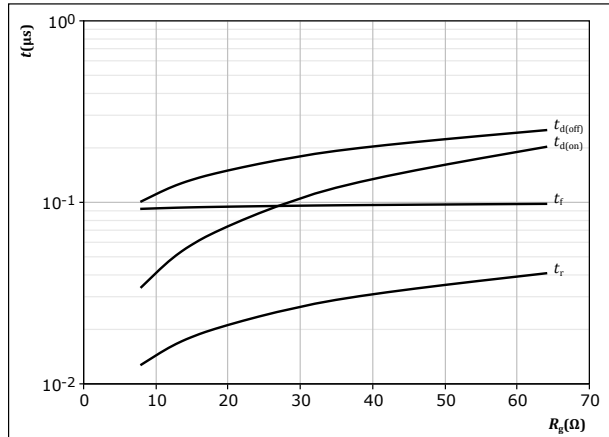

With an inductive load at
 $T_j = 150 \text{ }^\circ\text{C}$
 $V_{CE} = 350 \text{ V}$
 $V_{GE} = \pm 15 \text{ V}$
 $I_c = 15 \text{ A}$

figure 40. FWD

Typical reverse recovery time as a function of collector current
 $t_{rr} = f(I_c)$

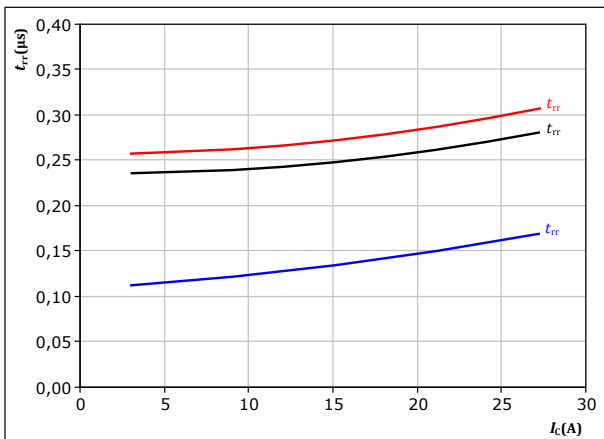

With an inductive load at
 $V_{CE} = 350 \text{ V}$
 $V_{GE} = \pm 15 \text{ V}$
 $R_{gon} = 32 \text{ } \Omega$
 $T_j:$ — 25 °C
 — 125 °C
 — 150 °C

figure 41. FWD

Typical reverse recovery time as a function of IGBT turn on gate resistor
 $t_{rr} = f(R_{gon})$

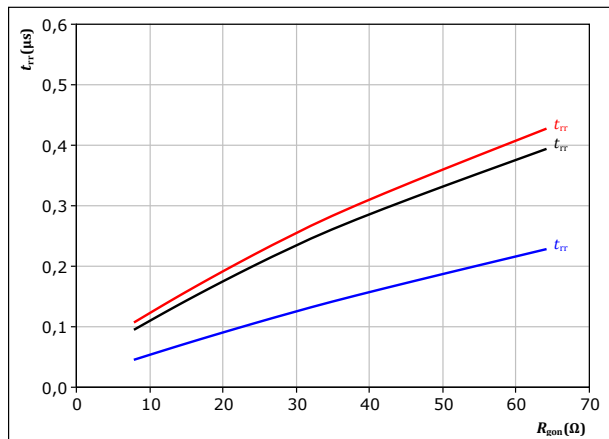

With an inductive load at
 $V_{CE} = 350 \text{ V}$
 $V_{GE} = \pm 15 \text{ V}$
 $I_c = 15 \text{ A}$
 $T_j:$ — 25 °C
 — 125 °C
 — 150 °C



Boost Switching Characteristics

figure 42. FWD

Typical recovered charge as a function of collector current

$$Q_r = f(I_c)$$

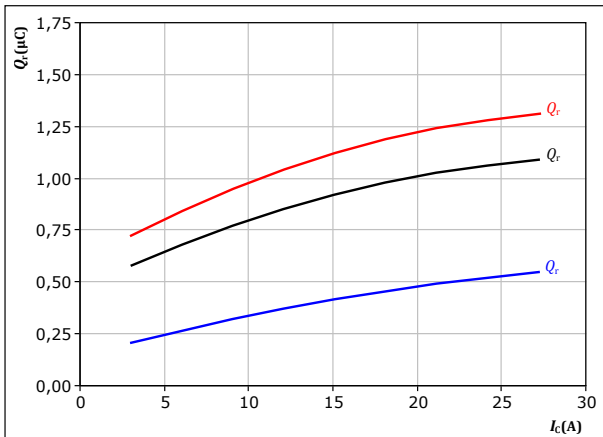

With an inductive load at

$V_{CE} = 350 \text{ V}$
 $V_{GE} = \pm 15 \text{ V}$
 $R_{gon} = 32 \ \Omega$

T_j :
 — 25 °C
 — 125 °C
 — 150 °C

figure 43. FWD

Typical recovered charge as a function of IGBT turn on gate resistor

$$Q_r = f(R_{gon})$$

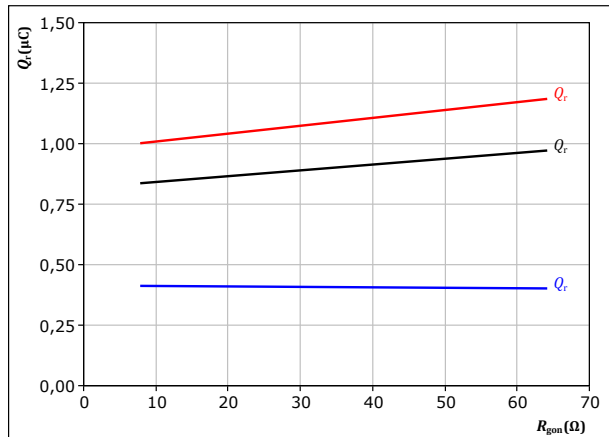

With an inductive load at

$V_{CE} = 350 \text{ V}$
 $V_{GE} = \pm 15 \text{ V}$
 $I_c = 15 \text{ A}$

T_j :
 — 25 °C
 — 125 °C
 — 150 °C

figure 44. FWD

Typical peak reverse recovery current as a function of collector current

$$I_{RM} = f(I_c)$$

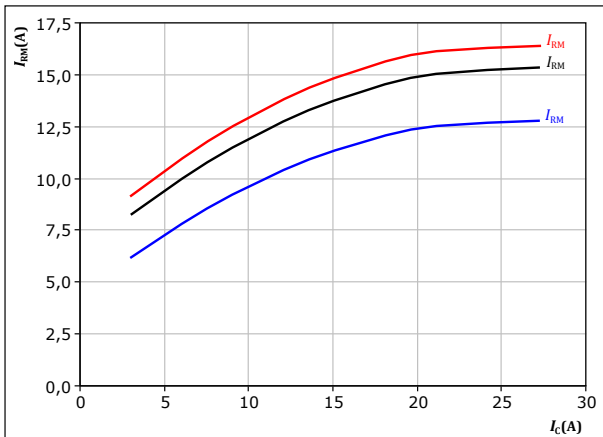

With an inductive load at

$V_{CE} = 350 \text{ V}$
 $V_{GE} = \pm 15 \text{ V}$
 $R_{gon} = 32 \ \Omega$

T_j :
 — 25 °C
 — 125 °C
 — 150 °C

figure 45. FWD

Typical peak reverse recovery current as a function of IGBT turn on gate resistor

$$I_{RM} = f(R_{gon})$$

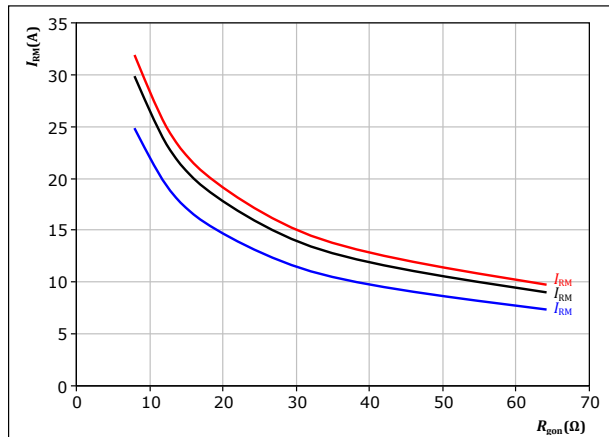

With an inductive load at

$V_{CE} = 350 \text{ V}$
 $V_{GE} = \pm 15 \text{ V}$
 $I_c = 15 \text{ A}$

T_j :
 — 25 °C
 — 125 °C
 — 150 °C



Boost Switching Characteristics

figure 46. FWD

Typical rate of fall of forward and reverse recovery current as a function of collector current
 $di_f/dt, di_r/dt = f(I_C)$

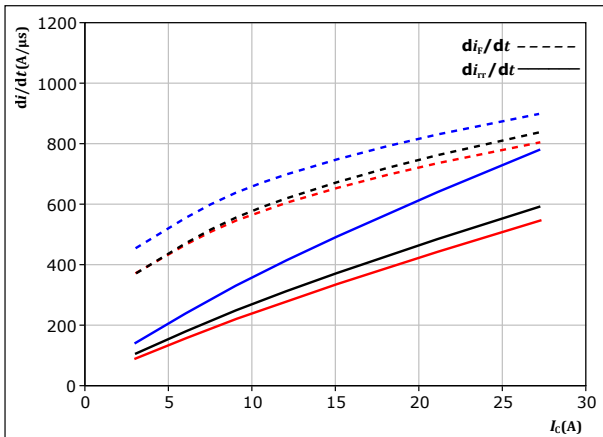

With an inductive load at
 $V_{CE} = 350 \text{ V}$
 $V_{GE} = \pm 15 \text{ V}$
 $R_{gon} = 32 \text{ } \Omega$

$T_j =$
— 25 °C
— 125 °C
— 150 °C

figure 47. FWD

Typical rate of fall of forward and reverse recovery current as a function of turn on gate resistor
 $di_f/dt, di_r/dt = f(R_{gon})$

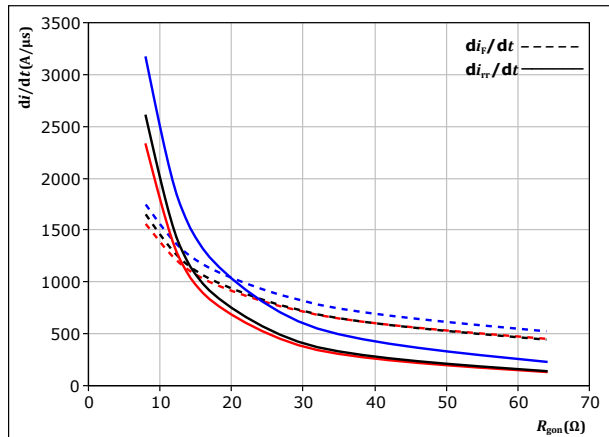

With an inductive load at
 $V_{CE} = 350 \text{ V}$
 $V_{GE} = \pm 15 \text{ V}$
 $I_C = 15 \text{ A}$

$T_j =$
— 25 °C
— 125 °C
— 150 °C

figure 48. IGBT

Reverse bias safe operating area
 $I_C = f(V_{CE})$

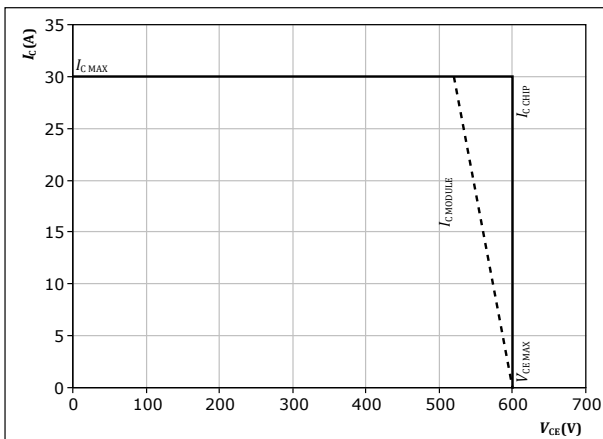

At $T_j = 150 \text{ } ^\circ\text{C}$
 $R_{gon} = 32 \text{ } \Omega$
 $R_{goff} = 32 \text{ } \Omega$



Switching Definitions

figure 49. IGBT

Turn-off Switching Waveforms & definition of t_{doff} , t_{Eoff} (t_{Eoff} = integrating time for E_{off})

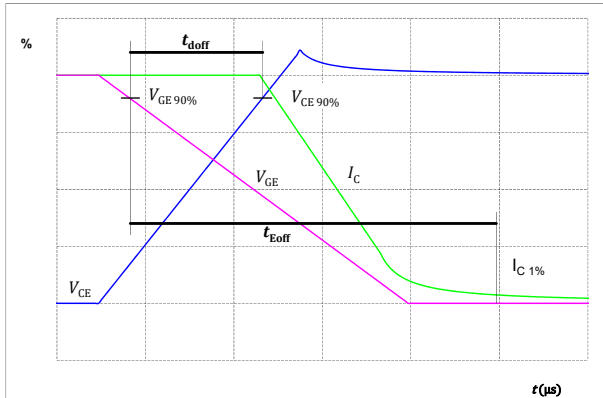

figure 50. IGBT

Turn-on Switching Waveforms & definition of t_{don} , t_{Eon} (t_{Eon} = integrating time for E_{on})

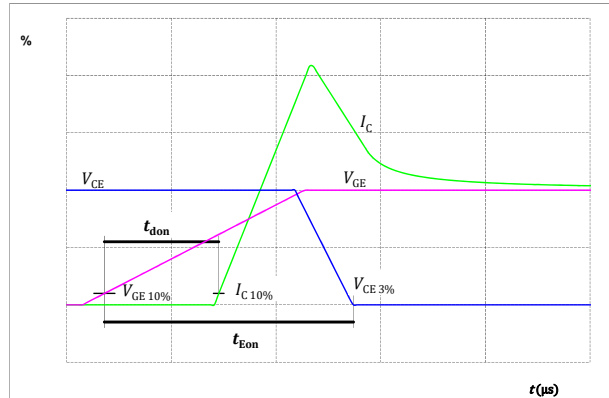

figure 51. IGBT

Turn-off Switching Waveforms & definition of t_f

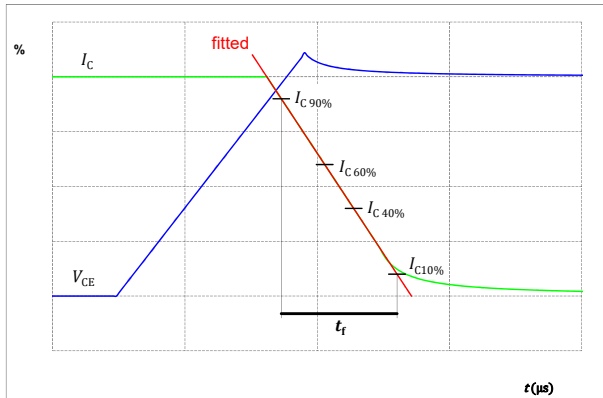
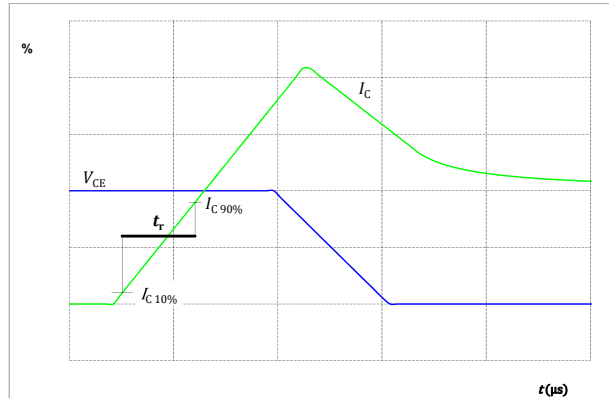

figure 52. IGBT

Turn-on Switching Waveforms & definition of t_r





Switching Definitions

figure 53. FWD

Turn-off Switching Waveforms & definition of t_{rr}

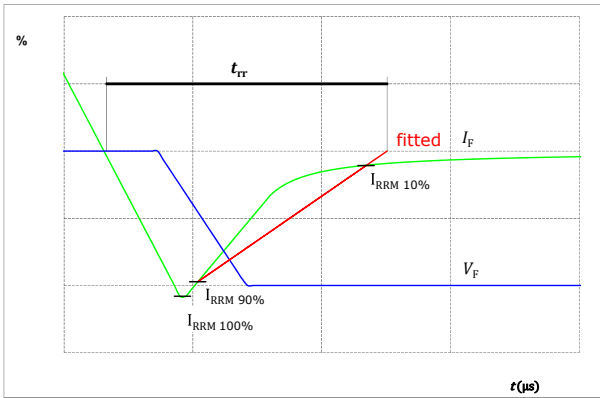
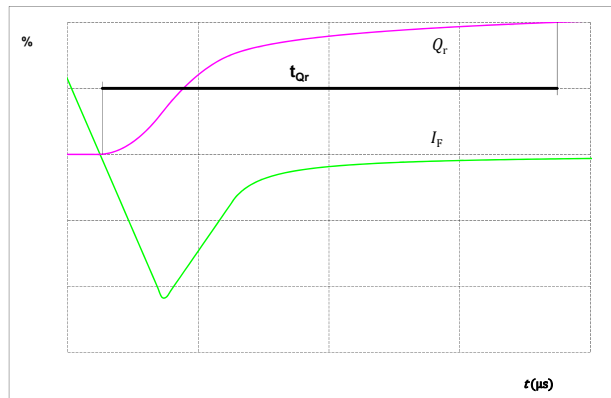

figure 54. FWD

Turn-on Switching Waveforms & definition of t_{Qr} (t_{Qr} = integrating time for Q_r)





Vincotech

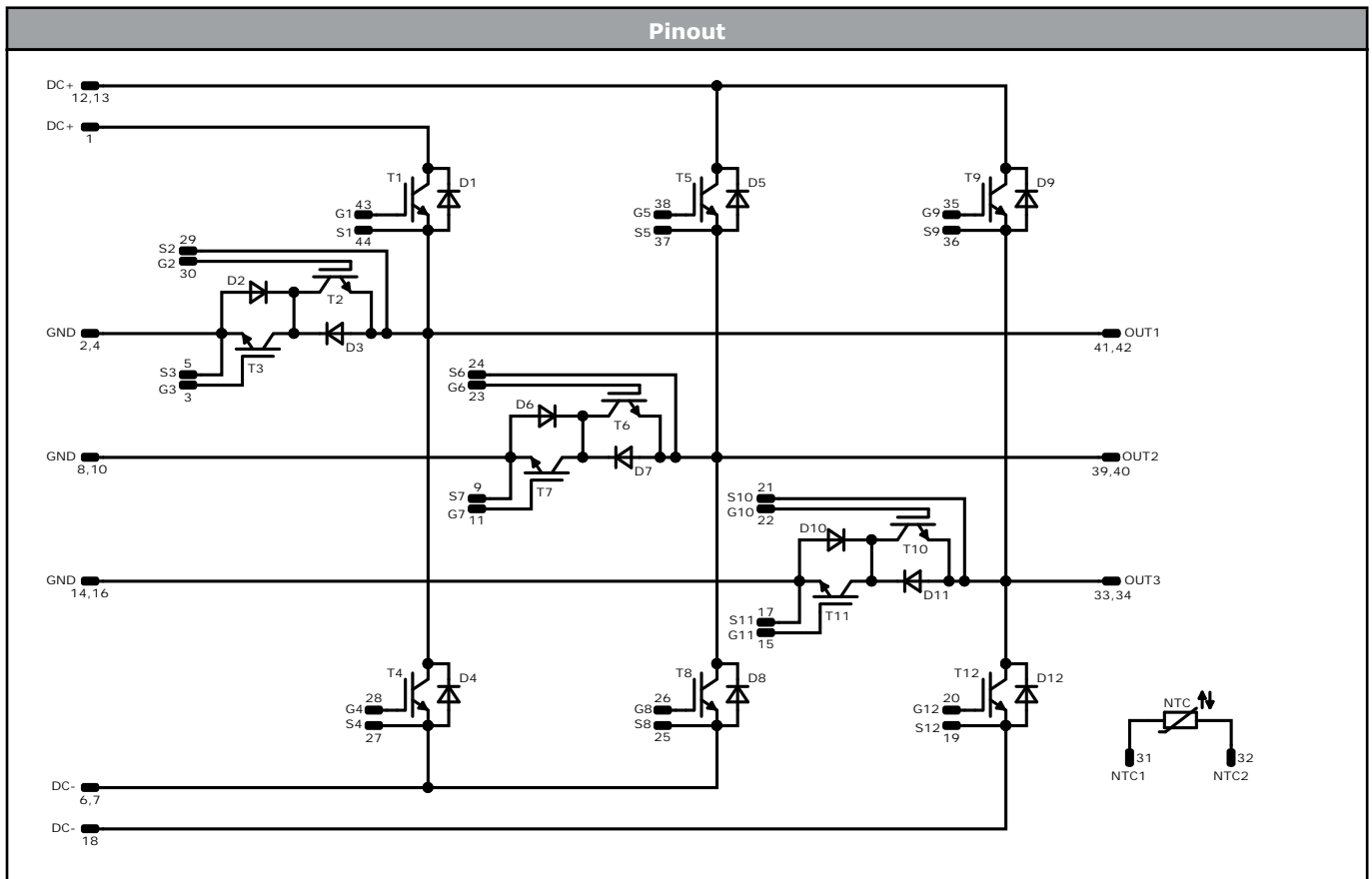

Identification					
ID	Component	Voltage	Current	Function	Comment
T1, T4, T5, T8, T9, T12	IGBT	1200 V	15 A	Buck Switch	
D2, D3, D6, D7, D10, D11	FWD	650 V	15 A	Buck Diode	
T3, T2, T7, T6, T11, T10	IGBT	600 V	15 A	Boost Switch	
D1, D4, D5, D8, D9, D12	FWD	1200 V	15 A	Boost Diode	
NTC	Thermistor			Thermistor	



Vincotech

Packaging instruction				
Standard packaging quantity (SPQ) 100	>SPQ	Standard	<SPQ	Sample

Handling instruction
Handling instructions for <i>flow 1</i> packages see vincotech.com website.

Package data
Package data for <i>flow 1</i> packages see vincotech.com website.

Vincotech thermistor reference
See Vincotech thermistor reference table at vincotech.com website.

UL recognition and file number
This device is certified according to UL 1557 standard, UL file number E192116. For more information see vincotech.com website. 

Document No.:	Date:	Modification:	Pages
10-PY12M3A015SH01-M743F68Y-D1-14	31 Jul. 2022		

DISCLAIMER

The information, specifications, procedures, methods and recommendations herein (together "information") are presented by Vincotech to reader in good faith, are believed to be accurate and reliable, but may well be incomplete and/or not applicable to all conditions or situations that may exist or occur. Vincotech reserves the right to make any changes without further notice to any products to improve reliability, function or design. No representation, guarantee or warranty is made to reader as to the accuracy, reliability or completeness of said information or that the application or use of any of the same will avoid hazards, accidents, losses, damages or injury of any kind to persons or property or that the same will not infringe third parties rights or give desired results. It is reader's sole responsibility to test and determine the suitability of the information and the product for reader's intended use.

LIFE SUPPORT POLICY

Vincotech products are not authorised for use as critical components in life support devices or systems without the express written approval of Vincotech.

As used herein:

1. Life support devices or systems are devices or systems which, (a) are intended for surgical implant into the body, or (b) support or sustain life, or (c) whose failure to perform when properly used in accordance with instructions for use provided in labelling can be reasonably expected to result in significant injury to the user.
2. A critical component is any component of a life support device or system whose failure to perform can be reasonably expected to cause the failure of the life support device or system, or to affect its safety or effectiveness.