



Vincotech

flow3xNPC 1

NPC Application

650 V / 15 A

General conditions

BUCK	
V_{GEon}	= 15 V
V_{GEoff}	= -15 V
R_{gon}	= 32 Ω
R_{goff}	= 32 Ω

$V_{out} = 230$ VAC

BOOST	
V_{GEon}	= 15 V
V_{GEoff}	= -15 V
R_{gon}	= 16 Ω
R_{goff}	= 16 Ω

Figure 1. Buck IGBT
Typical average static loss as a function of

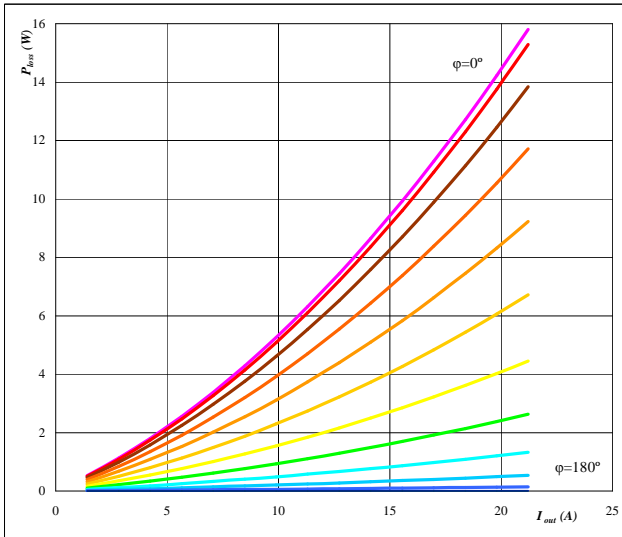

Conditions $T_j = 150$ °C
parameter φ from 0° to 180°
in 12 steps

Figure 2. Buck FWD
Typical average static loss as a function of output current I_{oRMS}

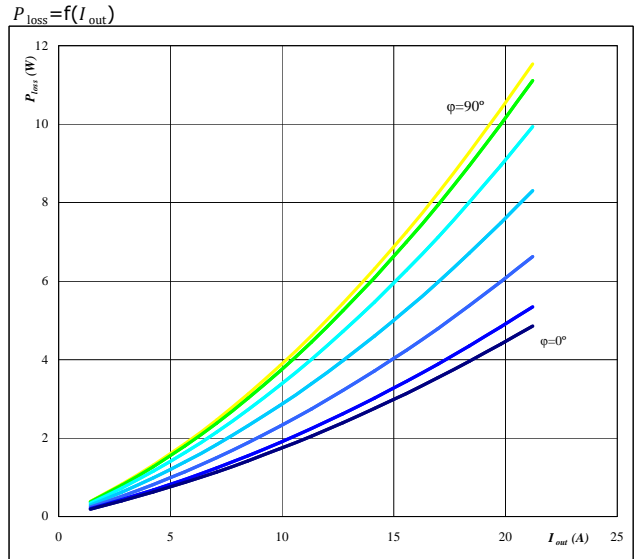

Conditions $T_j = 150$ °C
parameter φ from 0° to 180°
in 12 steps

Figure 3. Buck IGBT
Typical average static loss as a function of phase displacement φ

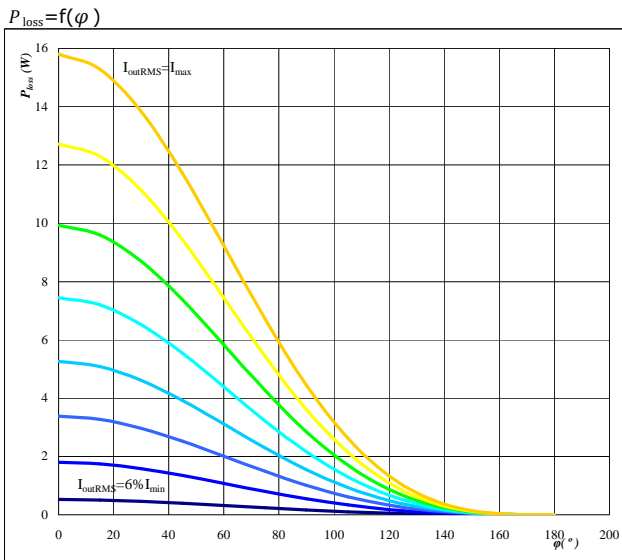

Conditions $T_j = 150$ °C
parameter I_{oRMS} from 1,41 A to 21 A
in steps of 3 A

Figure 4. Buck FWD
Typical average static loss as a function of phase displacement φ

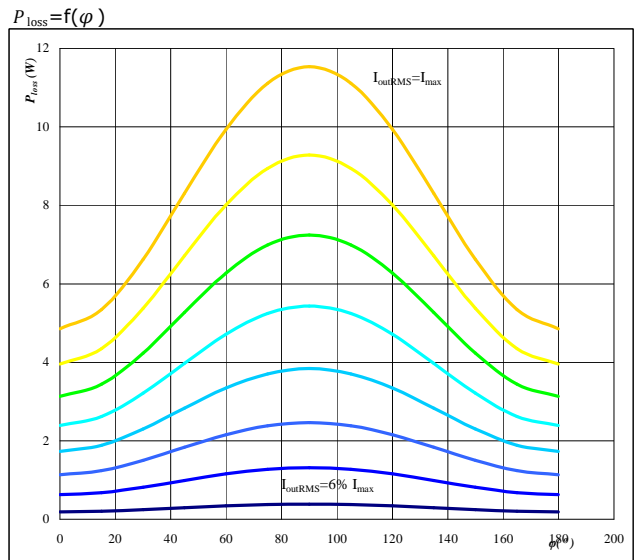

Conditions $T_j = 150$ °C
parameter I_{oRMS} from 1,41 A to 21 A
in steps of 3 A



Vincotech

flow3xNPC 1

NPC Application

650 V / 15 A

Figure 5. Buck IGBT

Typical average switching loss as a function of phase displacement φ

$P_{loss} = f(\varphi)$

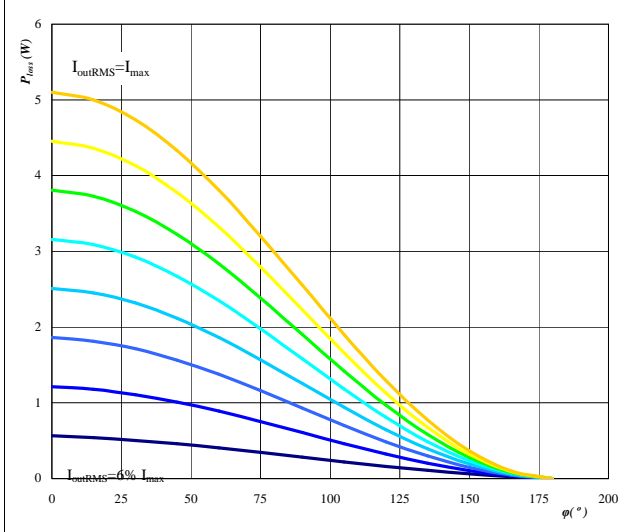

Conditions $T_j = 150$ °C
 $f_{sw} = 20$ kHz
 DC link = 700 V
 parameter I_{oRMS} from 1,41 A to 21 A
 in steps of 3 A

Figure 6. Buck FWD

Typical average switching loss as a function of phase displacement φ

$P_{loss} = f(\varphi)$

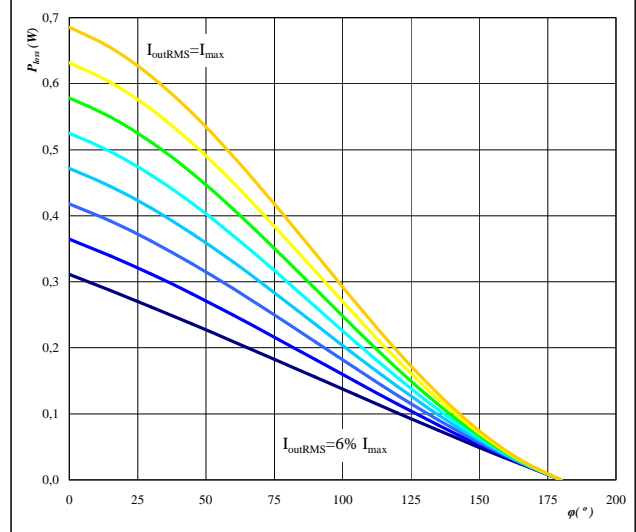

Conditions $T_j = 150$ °C
 $f_{sw} = 20$ kHz
 DC link = 700 V
 parameter I_{oRMS} from 1,41 A to 21 A
 in steps of 3 A

Figure 7. Buck IGBT

Typical total loss as a function of phase displacement φ and output current I_{oRMS}

$P_{loss} = f(I_{oRMS}; \varphi)$

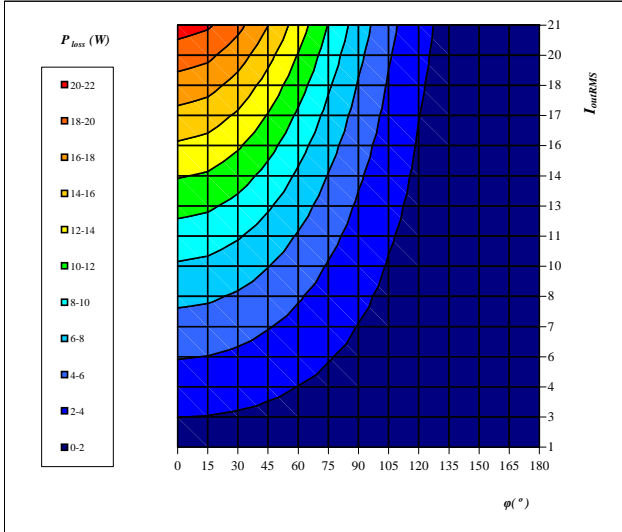

Conditions $T_j = 150$ °C
 DC link = 700 V
 $f_{sw} = 20$ kHz

Figure 8. Buck FWD

Typical total loss as a function of phase displacement φ and output current I_{oRMS}

$P_{loss} = f(I_{oRMS}; \varphi)$

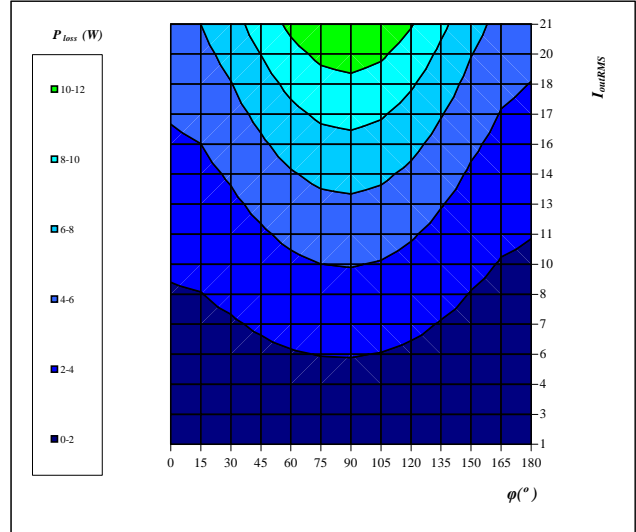

Conditions $T_j = 150$ °C
 DC link = 700 V
 $f_{sw} = 20$ kHz



Vincotech

flow3xNPC 1

NPC Application

650 V / 15 A

Figure 9. for Buck IGBT+FWD

Typical available output current as a function of phase displacement φ

$I_{out} = f(\varphi)$

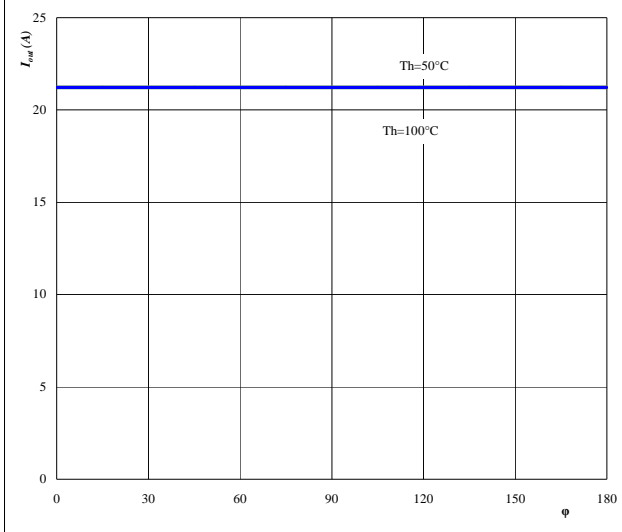

Conditions $T_j = T_{jmax} - 25 \text{ }^\circ\text{C}$ $f_{sw} = 20 \text{ kHz}$
 DC link = 700 V
 parameter: Heatsink temp.
 T_h from 50 $^\circ\text{C}$ to 100 $^\circ\text{C}$
 in 10 $^\circ\text{C}$ steps

Figure 10. for Buck IGBT+FWD

Typical available output current as a function of switching frequency f_{sw}

$I_{out} = f(f_{sw})$

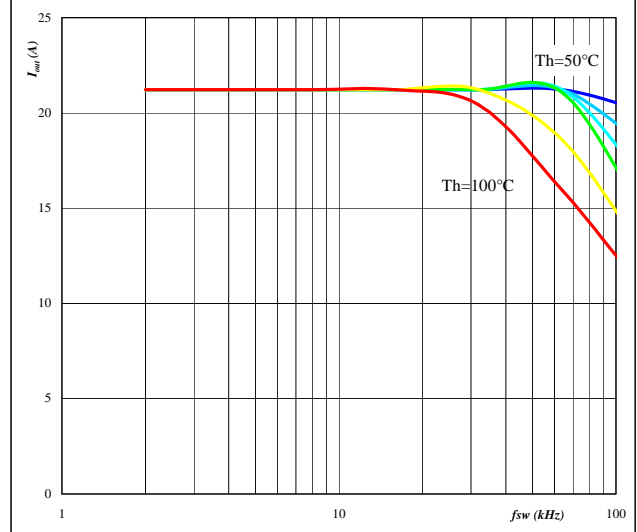

Conditions $T_j = T_{jmax} - 25 \text{ }^\circ\text{C}$ $\varphi = 0 \text{ }^\circ$
 DC link = 700 V
 parameter: Heatsink temp.
 T_h from 50 $^\circ\text{C}$ to 100 $^\circ\text{C}$
 in 10 $^\circ\text{C}$ steps

Figure 11. for Buck IGBT+FWD

Typical available 50Hz output current as a function of f_{sw} and phase displacement φ

$I_{out} = f(f_{sw}, \varphi)$

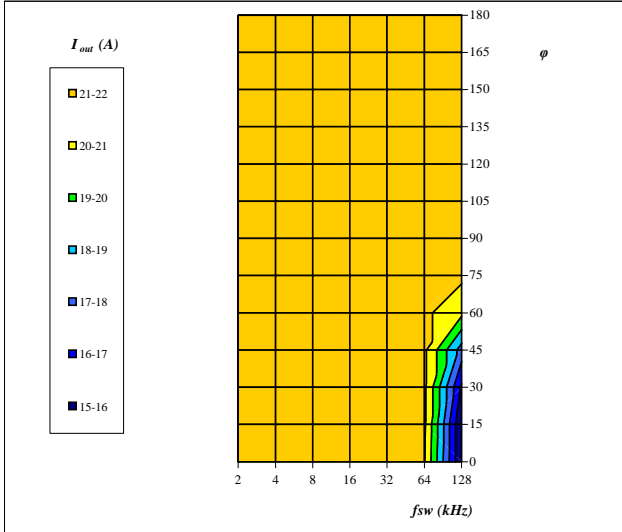

Conditions $T_j = T_{jmax} - 25 \text{ }^\circ\text{C}$
 DC link = 700 V
 $T_h = 80 \text{ }^\circ\text{C}$



Vincotech

flow3xNPC 1

NPC Application

650 V / 15 A

Figure 12. Boost IGBT

Typical average static loss as a function of output current

$$P_{\text{loss}} = f(I_{\text{out}})$$

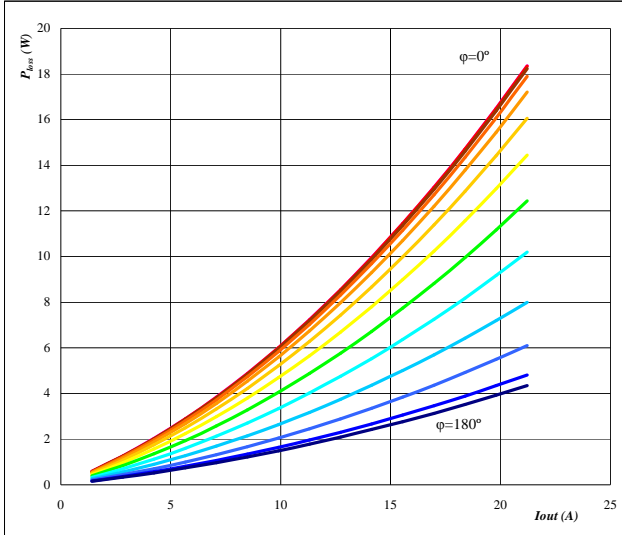

Conditions $T_j = 150$ °C
parameter φ from 0° to 180°
in 12 steps

Figure 13. Boost FWD

Typical average static loss as a function of output current

$$P_{\text{loss}} = f(I_{\text{out}})$$

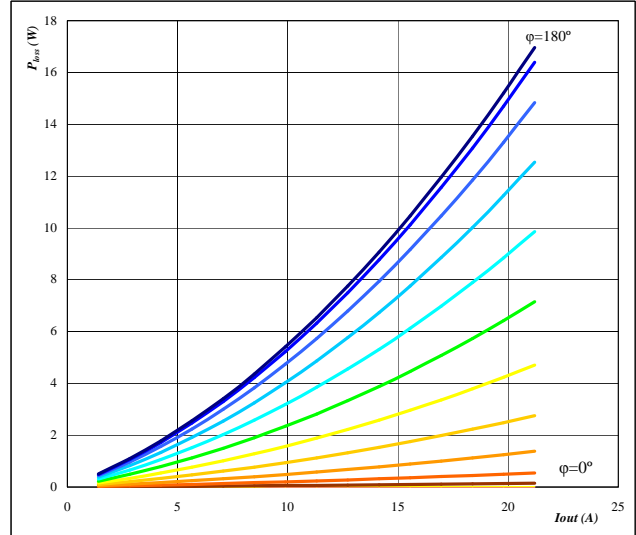

Conditions $T_j = 150$ °C
parameter φ from 0° to 180°
in 12 steps

Figure 14. Boost IGBT

Typical average static loss as a function of phase displacement

$$P_{\text{loss}} = f(\varphi)$$

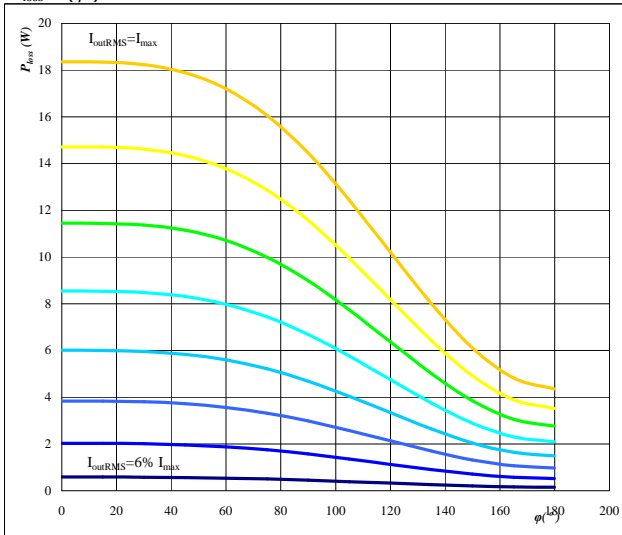

Conditions $T_j = 150$ °C
parameter I_{orRMS} from 1 A to 21 A
in steps of 3 A

Figure 15. Boost FWD

Typical average static loss as a function of phase displacement

$$P_{\text{loss}} = f(\varphi)$$

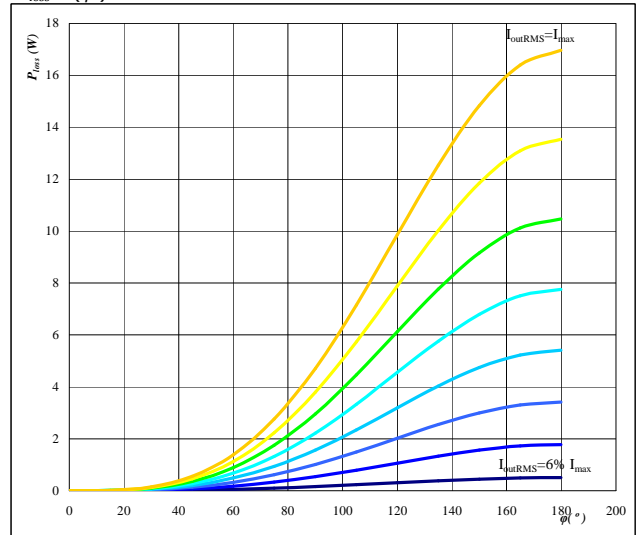

Conditions $T_j = 150$ °C
parameter I_{orRMS} from 1 A to 21 A
in steps of 3 A



Vincotech

flow3xNPC 1

NPC Application

650 V / 15 A

Figure 16. Boost IGBT

Typical average switching loss as a function of phase displacement

$$P_{loss} = f(\varphi)$$

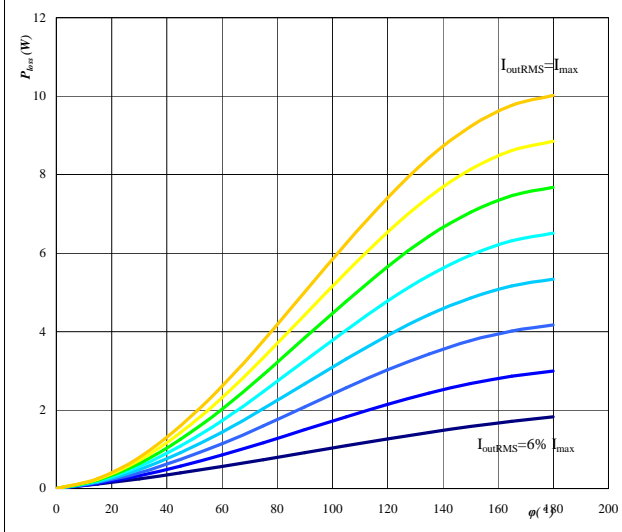

Conditions $T_j = 150$ °C $f_{sw} = 20$ kHz
 DC link = 700 V
 parameter I_{oRMS} from 1 A to 21 A
 in steps of 3 A A

Figure 17. Boost FWD

Typical average switching loss as a function of phase displacement

$$P_{loss} = f(\varphi)$$

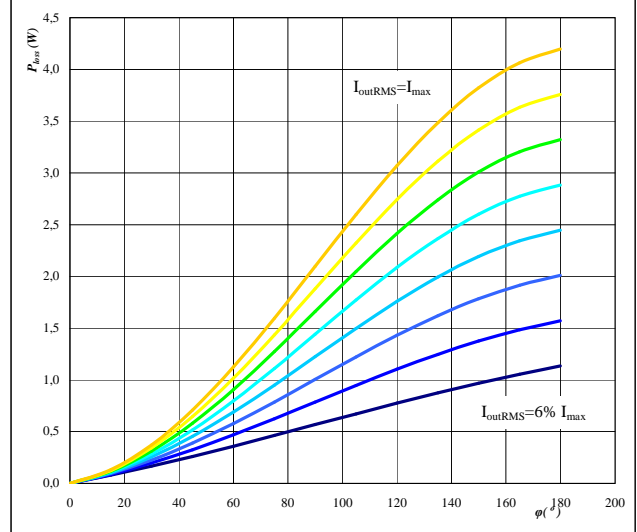

Conditions $T_j = 150$ °C $f_{sw} = 20$ kHz
 DC link = 700 V
 parameter I_{oRMS} from 1 A to 21 A
 in steps of 3 A A

Figure 18. Boost IGBT

Typical total loss as a function of phase displacement and I_{outRMS}

$$P_{loss} = f(I_{oRMS}; \varphi)$$

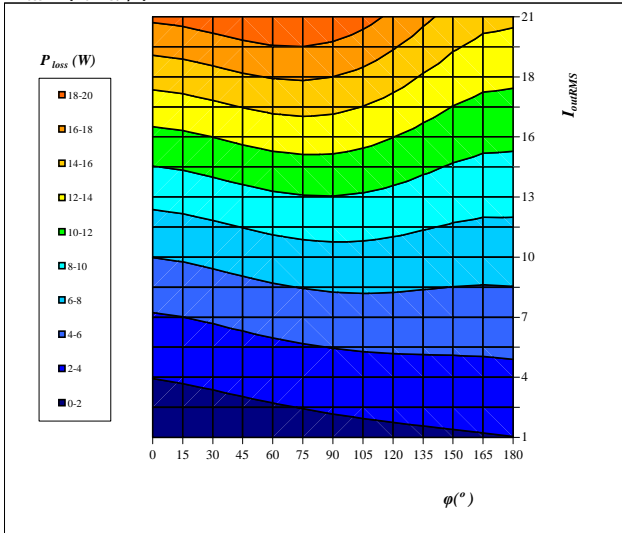

Conditions $T_j = 150$ °C
 DC link = 700 V
 $f_{sw} = 20$ kHz

Figure 19. Boost FWD

Typical total loss as a function of phase displacement and I_{outRMS}

$$P_{loss} = f(I_{oRMS}; \varphi)$$

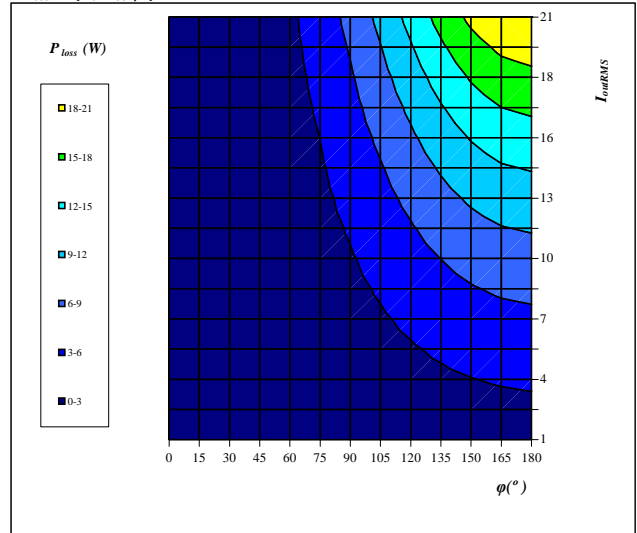

Conditions $T_j = 150$ °C
 DC link = 700 V
 $f_{sw} = 20$ kHz



Vincotech

flow3xNPC 1

NPC Application

650 V / 15 A

Figure 20. Boost IGBT+FWD

Typical available output current as a function of phase displacement

$$I_{out} = f(\varphi)$$

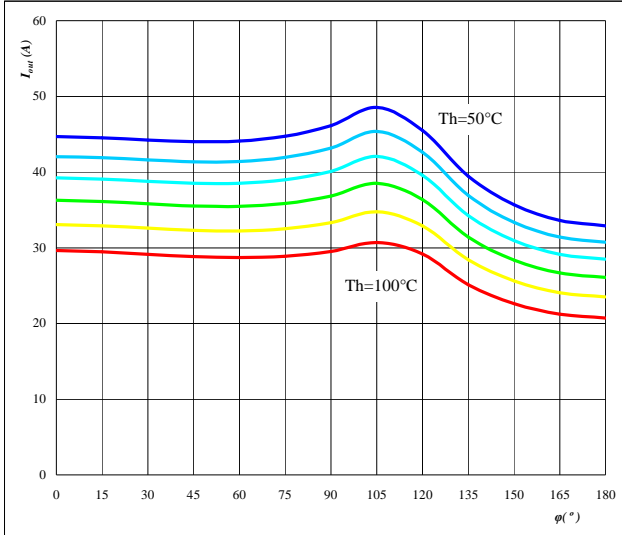

Conditions $T_j = T_{jmax} - 25 \text{ }^\circ\text{C}$ $f_{sw} = 20 \text{ kHz}$
 DC link = 700 V
 parameter: Heatsink temp.
 T_h from 50 $^\circ\text{C}$ to 100 $^\circ\text{C}$
 in 10 $^\circ\text{C}$ steps

Figure 21. Boost IGBT+FWD

Typical available output current as a function of switching frequency

$$I_{out} = f(f_{sw})$$

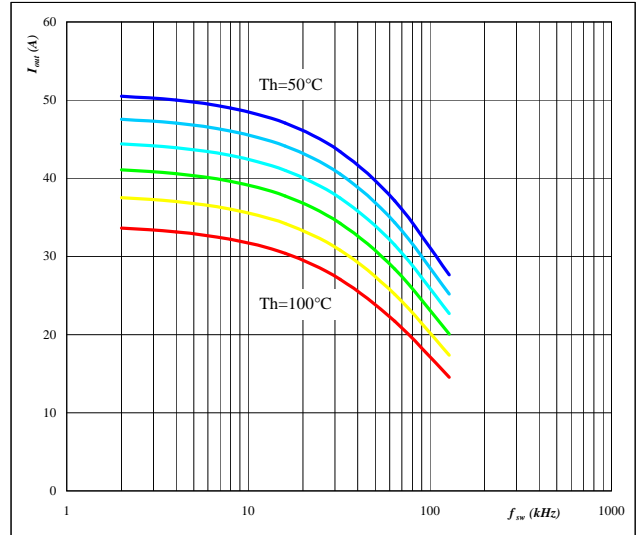

Conditions $T_j = T_{jmax} - 25 \text{ }^\circ\text{C}$ $\varphi = 90^\circ$
 DC link = 700 V
 parameter: Heatsink temp.
 T_h from 50 $^\circ\text{C}$ to 100 $^\circ\text{C}$
 in 10 $^\circ\text{C}$ steps

Figure 22. Boost IGBT+FWD

Typical available 50Hz output current as a function of f_{sw} and phase displacement

$$I_{out} = f(f_{sw}, \varphi)$$

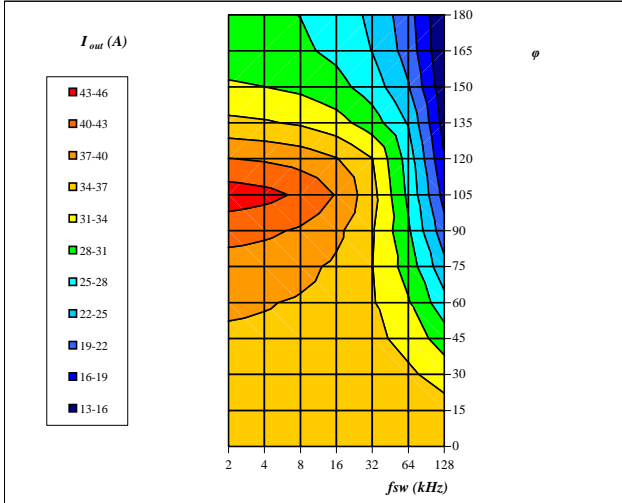

Conditions $T_j = T_{jmax} - 25 \text{ }^\circ\text{C}$
 DC link = 700 V
 $T_h = 80 \text{ }^\circ\text{C}$



Vincotech

flow3xNPC 1

NPC Application

650 V / 15 A

Figure 23. per MODULE

Typical available output current as a function of heat sink temperature

$$I_{out} = f(T_h)$$

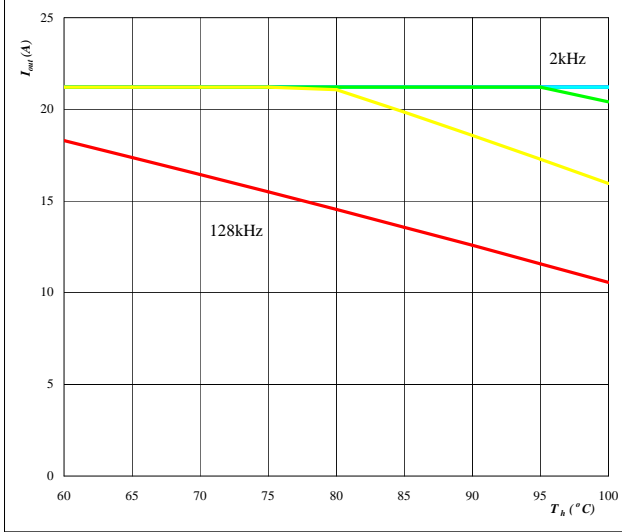

Conditions $T_j = T_{jmax} - 25$ °C
DC link = 700 V
 $\varphi = 0$ °
parameter: Switching freq.
 f_{sw} from 2 kHz to 128 kHz
in steps of factor 2

Figure 24. per MODULE

Typical available output current as a function of phase displacement

$$I_{out} = f(\varphi)$$

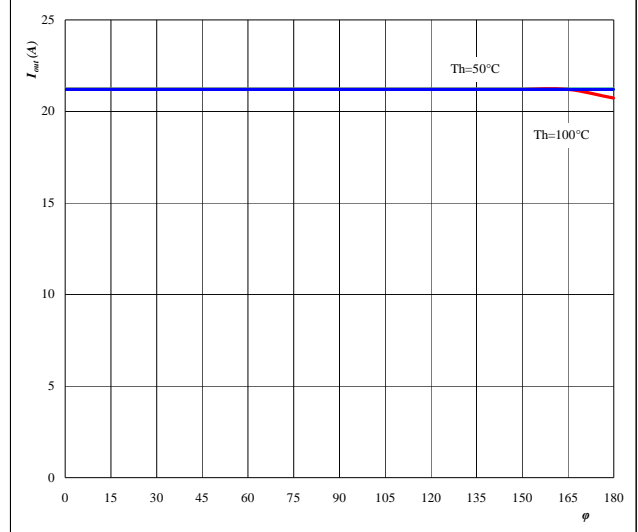

Conditions $T_j = T_{jmax} - 25$ °C
DC link = 700 V
 $f_{sw} = 20$ kHz
parameter: Heatsink temp.
 T_h from 50 °C to 100 °C
in 10 °C steps

Figure 25. per MODULE

Typical available output current as a function of switching frequency

$$I_{out} = f(f_{sw})$$

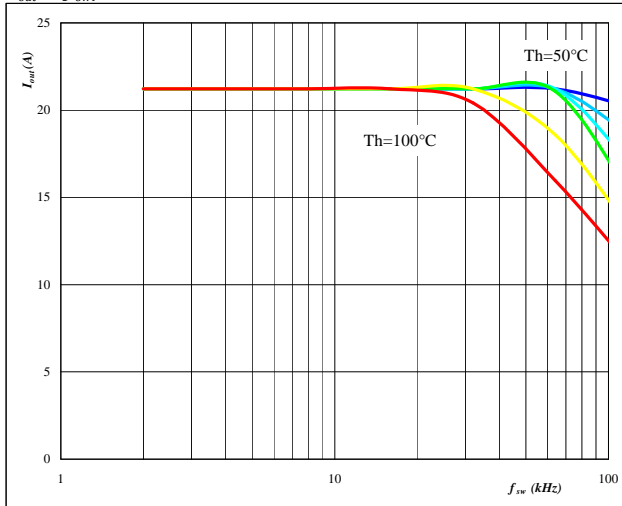

Conditions $T_j = T_{jmax} - 25$ °C $\varphi = 0$ °
DC link = 700 V
parameter: Heatsink temp.
 T_h from 50 °C to 100 °C
in 10 °C steps

Figure 26. per MODULE

Typical available 50Hz output current as a function of f_{sw} and phase displacement

$$I_{out} = f(f_{sw}, \varphi)$$

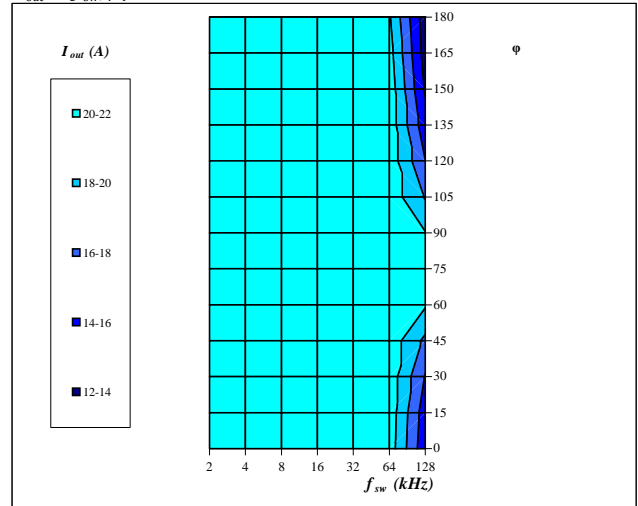

Conditions $T_j = T_{jmax} - 25$ °C
DC link = 700 V
 $T_h = 80$ °C



Vincotech

flow3xNPC 1

NPC Application

650 V / 15 A

Figure 27. per MODULE

Typical efficiency as a function of output power

$\eta = f(P_{out})$

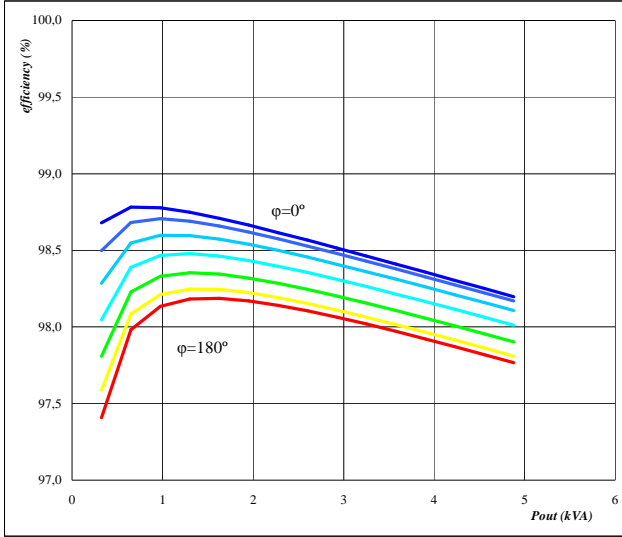

Conditions $T_j = 125$ °C
 $f_{sw} = 20$ kHz
 DC link = 700 V
 parameter: phase displacement
 φ from 0 ° to 180 °
 in steps of 30 °

Figure 28. per MODULE

Typical efficiency as a function of output power

$\eta = f(P_{out})$

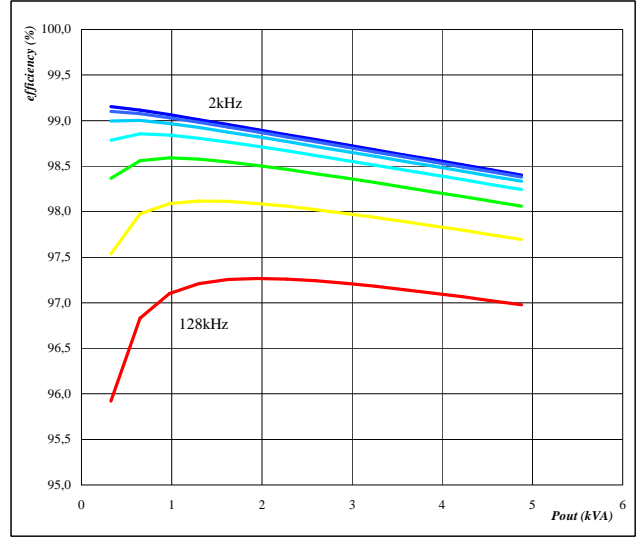

Conditions $T_j = 125$ °C $\varphi = 0$ °
 DC link = 700 V
 parameter: Switching freq.
 f_{sw} from 2 kHz to 128 kHz
 in steps of factor 2

Figure 29. per MODULE

Typical available output power as a function of heat sink temperature

$P_{out} = f(T_h)$

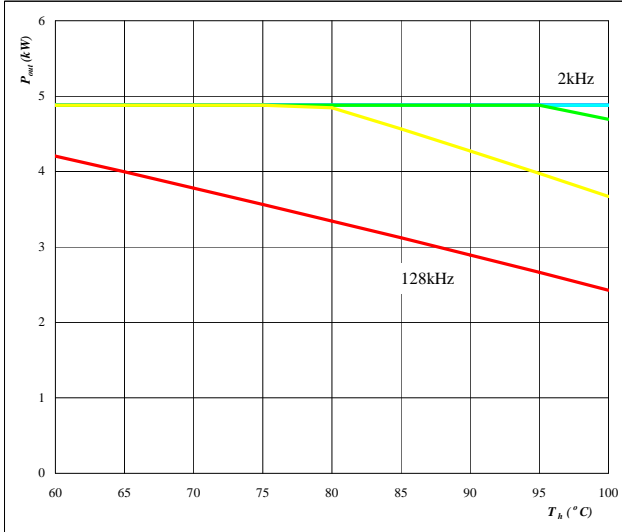

Conditions $T_j = T_{jmax} - 25$ °C
 DC link = 700 V
 $\varphi = 0$ °
 parameter: Switching freq.
 f_{sw} from 2 kHz to 128 kHz
 in steps of factor 2

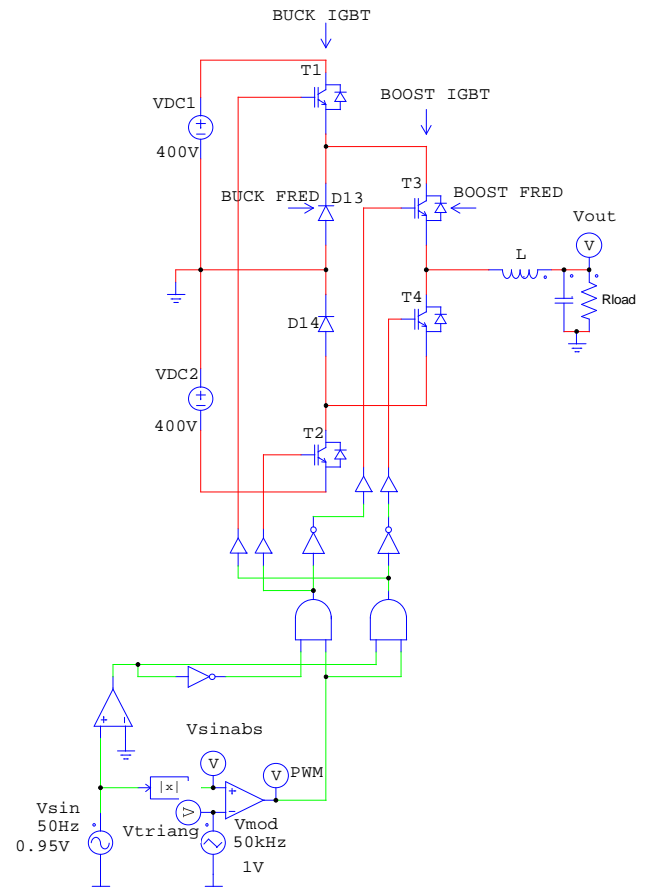



Vincotech

flow3xNPC 1

NPC Application

650 V / 15 A

Figure 30. per MODULE
Typical loss distribution as a function of output current
 $P_{out}=f(T_h)$

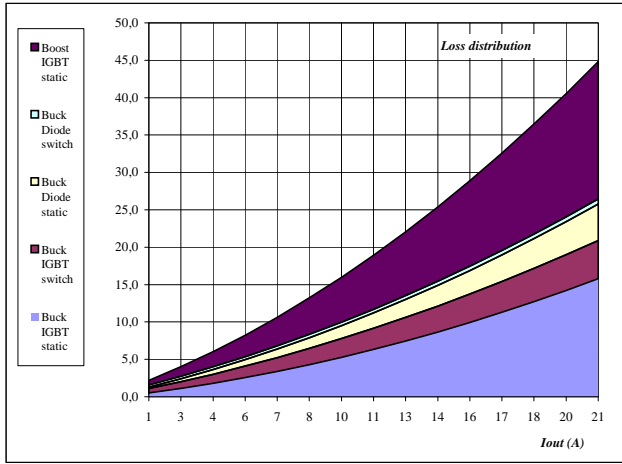

Conditions $T_j = 125$ °C
 $f_{sw} = 20$ kHz
DC link = 700 V
 $\varphi = 0^\circ$

Figure 31. per MODULE
Typical relativ loss distribution as a function of output current
 $P_{out}=f(T_h)$

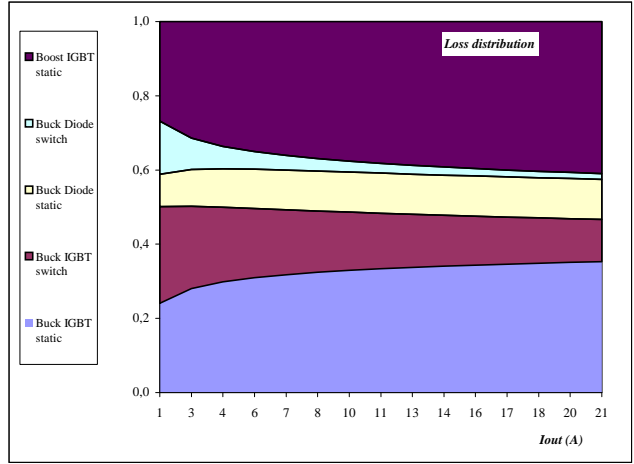

Conditions $T_j = 125$ °C
 $f_{sw} = 20$ kHz
DC link = 700 V
 $\varphi = 0^\circ$