

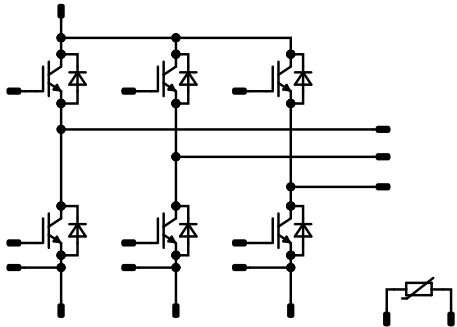

<b>flowPACK E1</b>		<b>600 V / 30 A</b>	
<b>Features</b>		<b>flow E1 12 mm housing</b>	
<ul style="list-style-type: none"><li>• Trench Fieldstop IGBT3 technology</li><li>• Standard industrial housing</li><li>• Optimized Rth(j-s) with Phase Change Material</li><li>• Built-in NTC</li></ul>			
<b>Target applications</b>		<b>Schematic</b>	
<ul style="list-style-type: none"><li>• Industrial Drives</li></ul>			
<b>Types</b>			
<ul style="list-style-type: none"><li>• 10-EZ066PA030SA-L854F38T</li></ul>			



Vincotech

**10-EZ066PA030SA-L854F38T**  
datasheet

## Maximum Ratings

$T_j = 25\text{ °C}$ , unless otherwise specified

Parameter	Symbol	Conditions	Value	Unit
<b>Inverter Switch</b>				
Collector-emitter voltage	$V_{CES}$		600	V
Collector current (DC current)	$I_C$	$T_j = T_{jmax}$ $T_s = 80\text{ °C}$	36	A
Repetitive peak collector current	$I_{CRM}$	$t_p$ limited by $T_{jmax}$	90	A
Total power dissipation	$P_{tot}$	$T_j = T_{jmax}$ $T_s = 80\text{ °C}$	73	W
Gate-emitter voltage	$V_{GES}$		$\pm 20$	V
Short circuit ratings	$t_{SC}$	$V_{GE} = 15\text{ V}$ , $V_{CC} = 360\text{ V}$ $T_j = 150\text{ °C}$	6	$\mu\text{s}$
Maximum junction temperature	$T_{jmax}$		175	$^{\circ}\text{C}$

## Inverter Diode

Peak repetitive reverse voltage	$V_{RRM}$		600	V
Forward current (DC current)	$I_F$	$T_j = T_{jmax}$ $T_s = 80\text{ °C}$	36	A
Repetitive peak forward current	$I_{FRM}$	$t_p$ limited by $T_{jmax}$	60	A
Total power dissipation	$P_{tot}$	$T_j = T_{jmax}$ $T_s = 80\text{ °C}$	58	W
Maximum junction temperature	$T_{jmax}$		175	$^{\circ}\text{C}$

## Module Properties

### Thermal Properties

Storage temperature	$T_{stg}$		-40...+125	$^{\circ}\text{C}$
Operation temperature under switching condition	$T_{jop}$		-40...+( $T_{jmax} - 25$ )	$^{\circ}\text{C}$

### Isolation Properties

Isolation voltage	$V_{isol}$	DC Test Voltage* $t_p = 2\text{ s}$	6000	V
Isolation voltage	$V'_{isol}$	AC Voltage $t_p = 1\text{ min}$	2500	V
Creepage distance			>12,7	mm
Clearance			8,62	mm
Comparative Tracking Index	CTI		$\geq 600$	

\*100 % tested in production



Vincotech

### Characteristic Values

Parameter	Symbol	Conditions					Values			Unit
		$V_{GS}$ [V]	$V_{GE}$ [V]	$V_{DS}$ [V]	$I_D$ [A]	$T_j$ [°C]	Min	Typ	Max	

#### Inverter Switch

##### Static

Gate-emitter threshold voltage	$V_{GE(th)}$	$V_{CE} = V_{GE}$			0,00043	25	5	5,8	6,5	V
Collector-emitter saturation voltage	$V_{CE(sat)}$		15		30	25 150	1,1	1,57 1,8	1,9 <sup>(1)</sup>	V
Collector-emitter cut-off current	$I_{CES}$		0	600		25			1,6	μA
Gate-emitter leakage current	$I_{GES}$		20	0		25			300	nA
Internal gate resistance	$r_g$							None		Ω
Input capacitance	$C_{ies}$							1630		pF
Output capacitance	$C_{oes}$	$f = 1$ Mhz	0	25		25		108		pF
Reverse transfer capacitance	$C_{res}$							50		pF

##### Thermal

Thermal resistance junction to sink <sup>(2)</sup>	$R_{th(j-s)}$	$\lambda_{paste} = 3,4$ W/mK (PSX)						1,29		K/W
--	---------------	---------------------------------------	--	--	--	--	--	------	--	-----

##### Dynamic

Turn-on delay time	$t_{d(on)}$	$R_{gon} = 16$ Ω $R_{goff} = 16$ Ω	±15	300	30	25		106		ns
Rise time	$t_r$					150		103,8		
						25		14,4		ns
Turn-off delay time	$t_{d(off)}$					150		19,6		
						25		145,8		ns
Fall time	$t_f$					150		170,8		
						25		92,37		ns
Turn-on energy (per pulse)	$E_{on}$	150		111,67						
		25		0,475		mWs				
Turn-off energy (per pulse)	$E_{off}$	150		0,665						
		25		0,675		mWs				
						150		0,913		



Vincotech

10-EZ066PA030SA-L854F38T  
datasheet

### Characteristic Values

Parameter	Symbol	Conditions					Values			Unit
		$V_{GE}$ [V] $V_{GS}$ [V]	$V_{CE}$ [V] $V_{DS}$ [V] $V_F$ [V]	$I_C$ [A] $I_D$ [A] $I_F$ [A]	$T_j$ [°C]	Min	Typ	Max		

#### Inverter Diode

##### Static

Forward voltage	$V_F$				30	25 150	1,25	1,64 1,55	1,95 <sup>(1)</sup>	V
Reverse leakage current	$I_R$	$V_i = 600$ V				25			27	μA

##### Thermal

Thermal resistance junction to sink <sup>(2)</sup>	$R_{th(j-s)}$	$\lambda_{paste} = 3,4$ W/mK (PSX)						1,63		K/W
--	---------------	---------------------------------------	--	--	--	--	--	------	--	-----

##### Dynamic

Peak recovery current	$I_{RRM}$	$di/dt=2285$ A/μs $di/dt=1902$ A/μs	±15	300	30	25		27,01		A
						150		33,86		
Reverse recovery time	$t_{rr}$					25		146,13		
						150		253,4		
Recovered charge	$Q_r$					25		1,34		
						150		2,65		
Reverse recovered energy	$E_{rec}$	25		0,29						
		150		0,568						
Peak rate of fall of recovery current	$(di_{rr}/dt)_{max}$	25		1752						
		150		815,19						



Vincotech

### Characteristic Values

Parameter	Symbol	Conditions					Values			Unit
		$V_{GS}$ [V]	$V_{GE}$ [V]	$V_{DS}$ [V]	$V_{CE}$ [V]	$T_j$ [°C]	Min	Typ	Max	

### Thermistor

#### Static

Rated resistance	$R$					25		5		kΩ
Deviation of $R_{100}$	$A_{R/R}$	$R_{100} = 493 \Omega$				100	-5		5	%
Power dissipation	$P$							245		mW
Power dissipation constant	$d$					25		1,4		mW/K
B-value	$B_{(25/50)}$	Tol. $\pm 2 \%$						3375		K
B-value	$B_{(25/100)}$	Tol. $\pm 2 \%$						3437		K
Vincotech Thermistor Reference									K	

<sup>(1)</sup> Value at chip level

<sup>(2)</sup> Only valid with pre-applied Vincotech thermal interface material.



## Inverter Switch Characteristics

figure 1. IGBT

Typical output characteristics

$$I_C = f(V_{CE})$$

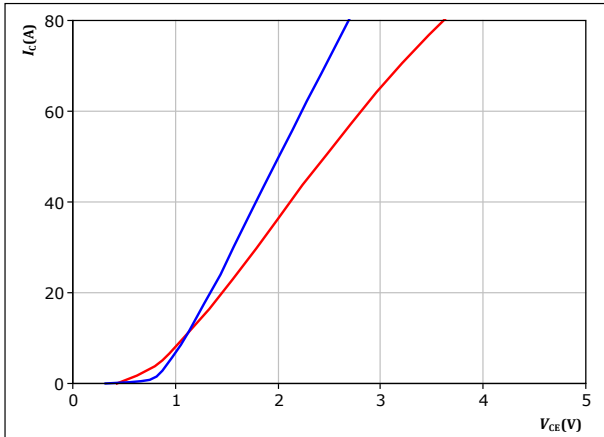

$t_p = 250 \mu\text{s}$   
 $V_{GE} = 15 \text{ V}$   
 $T_j: 25^\circ\text{C}$  (blue),  $150^\circ\text{C}$  (red)

figure 2. IGBT

Typical output characteristics

$$I_C = f(V_{CE})$$

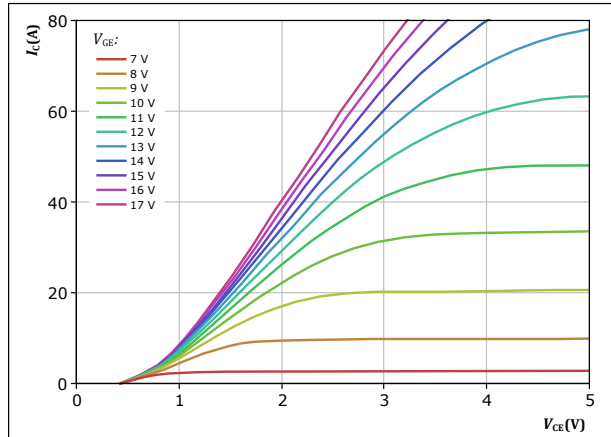

$t_p = 250 \mu\text{s}$   
 $T_j = 150^\circ\text{C}$   
 $V_{GE}$  from 7 V to 17 V in steps of 1 V

figure 3. IGBT

Typical transfer characteristics

$$I_C = f(V_{GE})$$

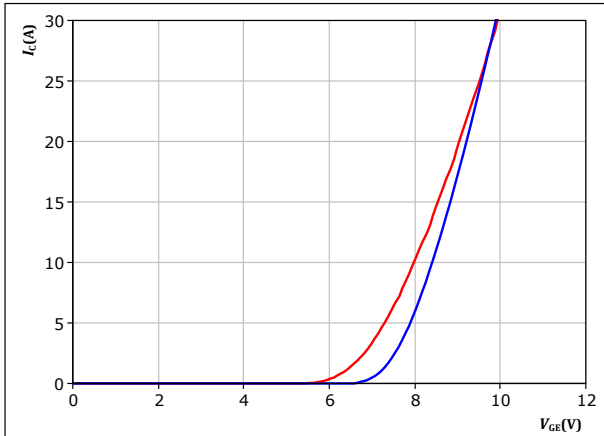

$t_p = 250 \mu\text{s}$   
 $V_{CE} = 10 \text{ V}$   
 $T_j: 25^\circ\text{C}$  (blue),  $150^\circ\text{C}$  (red)

figure 4. IGBT

Transient thermal impedance as a function of pulse width

$$Z_{th(j-s)} = f(t_p)$$

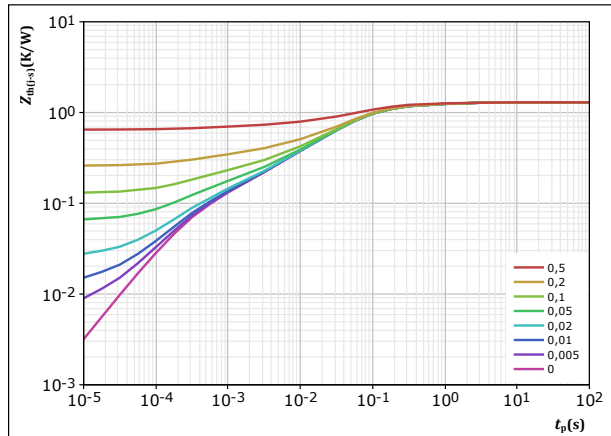

$D = t_p / T$   
 $R_{th(j-s)} = 1,295 \text{ K/W}$   
IGBT thermal model values

$R$ (K/W)	$\tau$ (s)
8,66E-02	1,69E+00
1,77E-01	2,34E-01
7,04E-01	5,82E-02
1,82E-01	1,03E-02
6,93E-02	1,92E-03
7,70E-02	3,01E-04



Vincotech

## Inverter Switch Characteristics

figure 5. IGBT

Safe operating area

$$I_C = f(V_{CE})$$

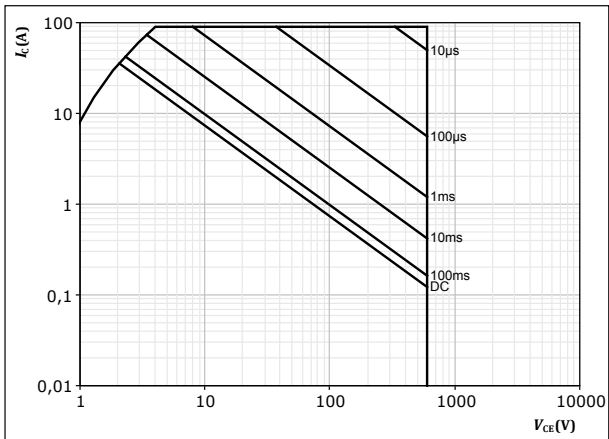

$D =$  single pulse

$T_s = 80$  °C

$V_{CE} = 15$  V

$T_j = T_{jmax}$



## Inverter Diode Characteristics

**figure 6.** FWD

Typical forward characteristics

$$I_F = f(V_F)$$

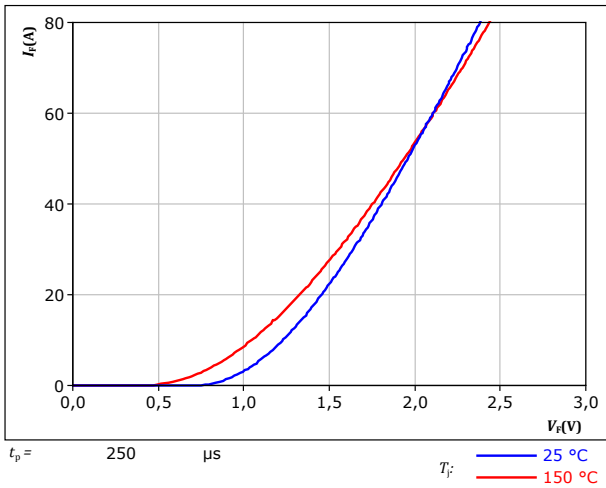

**figure 7.** FWD

Transient thermal impedance as a function of pulse width

$$Z_{th(j-s)} = f(t_p)$$

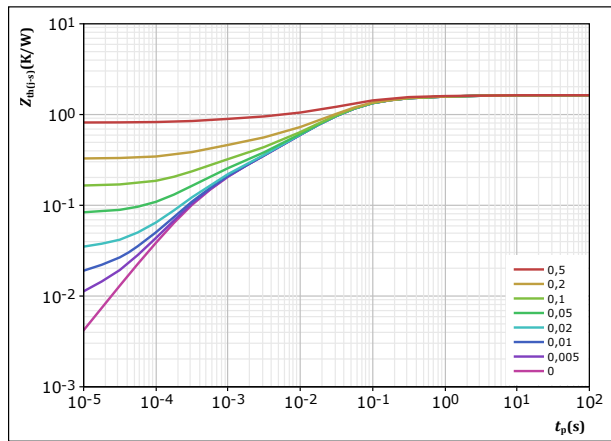

$D = t_p / T$   
 $R_{th(j-s)} = 1,633 \text{ K/W}$   
 FWD thermal model values

$R$ (K/W)	$\tau$ (s)
7,13E-02	2,70E+00
1,55E-01	3,01E-01
7,25E-01	5,48E-02
3,93E-01	1,54E-02
1,57E-01	2,76E-03
1,32E-01	4,03E-04





### Thermistor Characteristics

figure 8. Thermistor

Typical NTC characteristic as function of temperature

$$R_T = f(T)$$

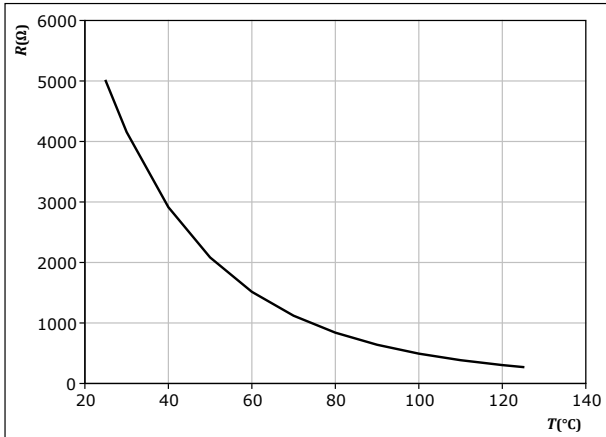



## Inverter Switching Characteristics

**figure 9.** IGBT

Typical switching energy losses as a function of collector current  
 $E = f(I_c)$

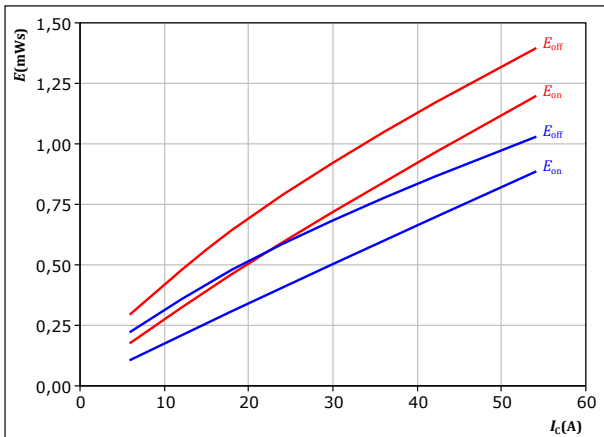

With an inductive load at  
 $V_{CE} = 300$  V  
 $V_{GE} = \pm 15$  V  
 $R_{gon} = 16$   $\Omega$   
 $R_{goff} = 16$   $\Omega$

$T_j$ : — 25 °C  
 — 150 °C

**figure 10.** IGBT

Typical switching energy losses as a function of gate resistor  
 $E = f(R_g)$

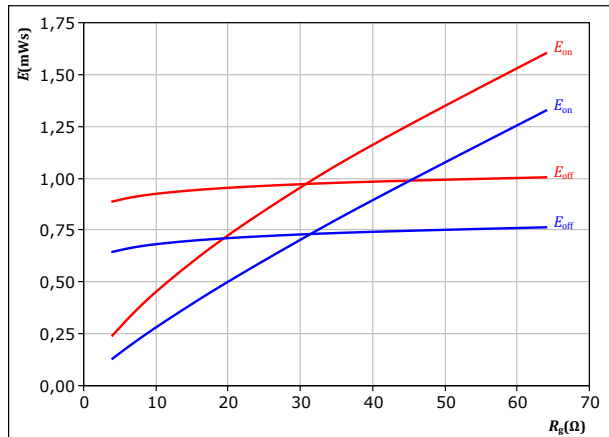

With an inductive load at  
 $V_{CE} = 300$  V  
 $V_{GE} = \pm 15$  V  
 $I_c = 30$  A

$T_j$ : — 25 °C  
 — 150 °C

**figure 11.** FWD

Typical reverse recovered energy loss as a function of collector current  
 $E_{rec} = f(I_c)$

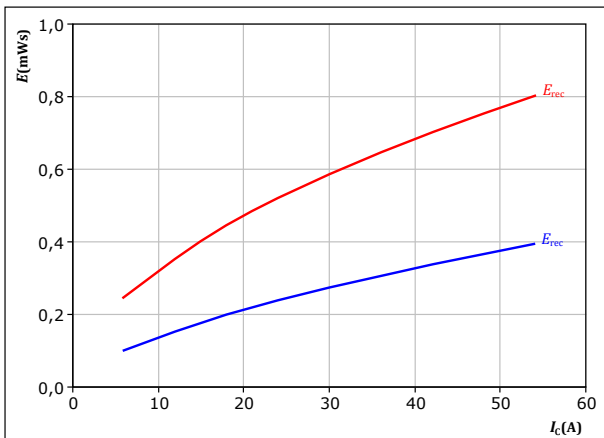

With an inductive load at  
 $V_{CE} = 300$  V  
 $V_{GE} = \pm 15$  V  
 $R_{gon} = 16$   $\Omega$

$T_j$ : — 25 °C  
 — 150 °C

**figure 12.** FWD

Typical reverse recovered energy loss as a function of gate resistor  
 $E_{rec} = f(R_g)$

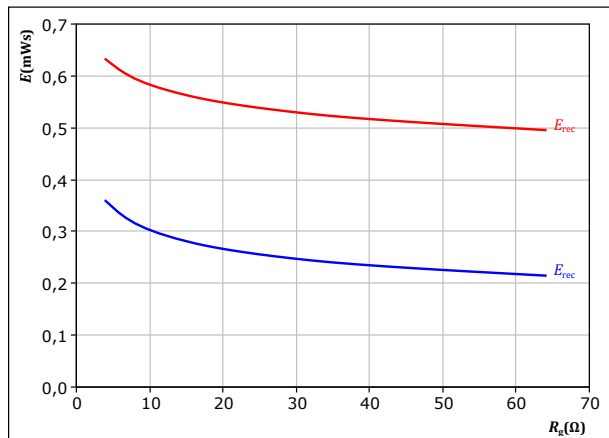

With an inductive load at  
 $V_{CE} = 300$  V  
 $V_{GE} = \pm 15$  V  
 $I_c = 30$  A

$T_j$ : — 25 °C  
 — 150 °C



## Inverter Switching Characteristics

**figure 13.** IGBT

Typical switching times as a function of collector current  
 $t = f(I_c)$

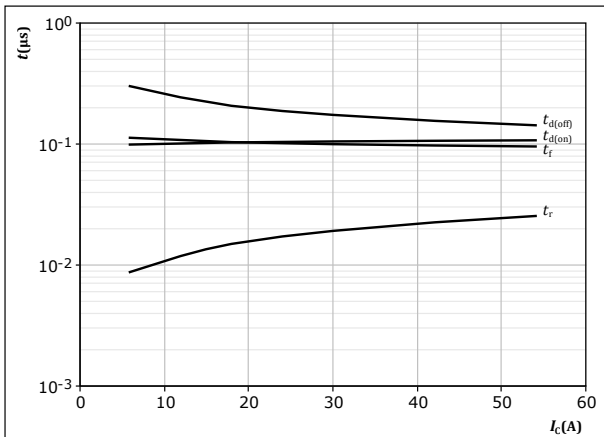

With an inductive load at  
 $T_j = 150 \text{ }^\circ\text{C}$   
 $V_{CE} = 300 \text{ V}$   
 $V_{GE} = \pm 15 \text{ V}$   
 $R_{g(on)} = 16 \text{ } \Omega$   
 $R_{g(off)} = 16 \text{ } \Omega$

**figure 14.** IGBT

Typical switching times as a function of gate resistor  
 $t = f(R_g)$

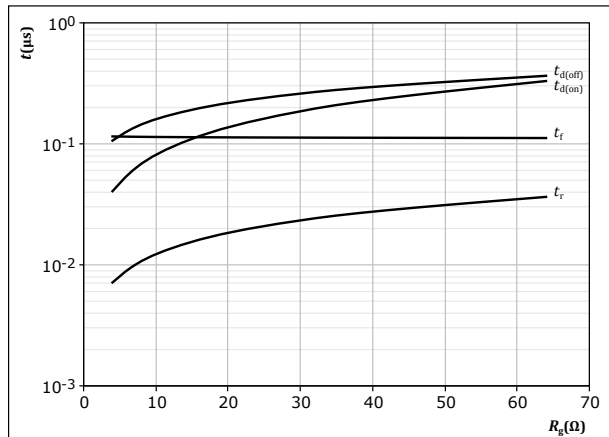

With an inductive load at  
 $T_j = 150 \text{ }^\circ\text{C}$   
 $V_{CE} = 300 \text{ V}$   
 $V_{GE} = \pm 15 \text{ V}$   
 $I_c = 30 \text{ A}$

**figure 15.** FWD

Typical reverse recovery time as a function of collector current  
 $t_{rr} = f(I_c)$

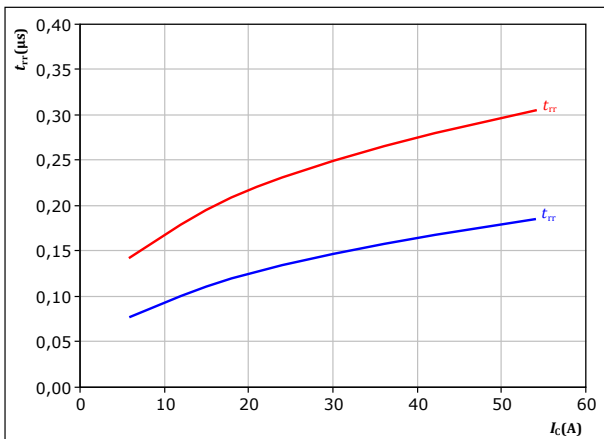

With an inductive load at  
 $V_{CE} = 300 \text{ V}$   
 $V_{GE} = \pm 15 \text{ V}$   
 $R_{g(on)} = 16 \text{ } \Omega$   
 $T_j$ : — 25  $^\circ\text{C}$   
           — 150  $^\circ\text{C}$

**figure 16.** FWD

Typical reverse recovery time as a function of IGBT turn off gate resistor  
 $t_{rr} = f(R_{g(off)})$

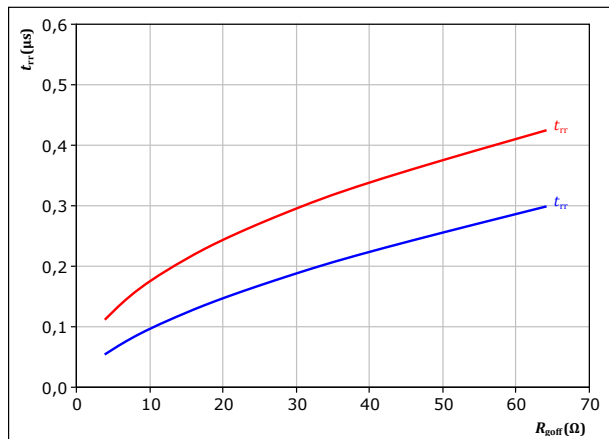

With an inductive load at  
 $V_{CE} = 300 \text{ V}$   
 $V_{GE} = \pm 15 \text{ V}$   
 $I_c = 30 \text{ A}$   
 $T_j$ : — 25  $^\circ\text{C}$   
           — 150  $^\circ\text{C}$



## Inverter Switching Characteristics

**figure 17.** FWD

Typical recovered charge as a function of collector current

$$Q_r = f(I_c)$$

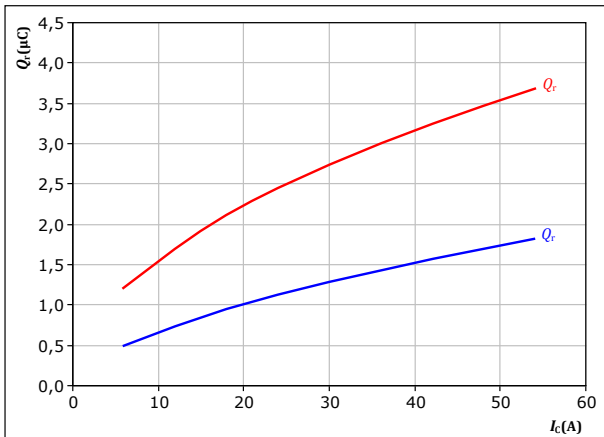

With an inductive load at

$V_{CE} = 300$  V  
 $V_{GE} = \pm 15$  V  
 $R_{goff} = 16$   $\Omega$

$T_j$ : — 25 °C  
— 150 °C

**figure 18.** FWD

Typical recovered charge as a function of turn off gate resistor

$$Q_r = f(R_{goff})$$

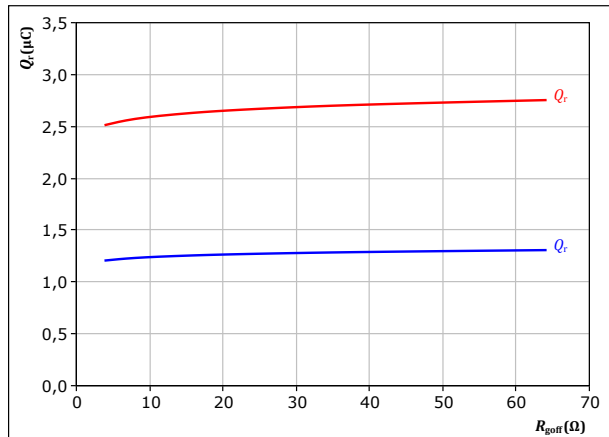

With an inductive load at

$V_{CE} = 300$  V  
 $V_{GE} = \pm 15$  V  
 $I_c = 30$  A

$T_j$ : — 25 °C  
— 150 °C

**figure 19.** FWD

Typical peak reverse recovery current as a function of collector current

$$I_{RM} = f(I_c)$$

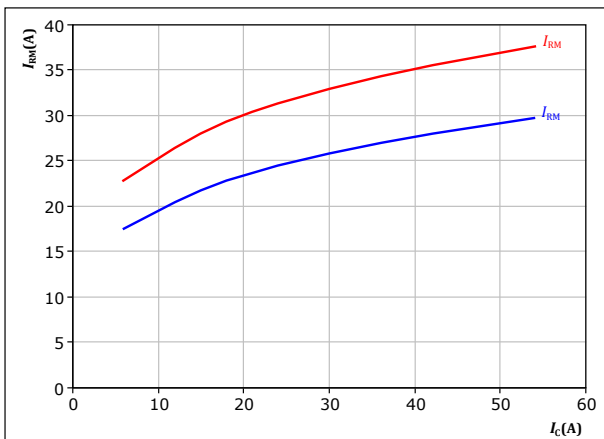

With an inductive load at

$V_{CE} = 300$  V  
 $V_{GE} = \pm 15$  V  
 $R_{goff} = 16$   $\Omega$

$T_j$ : — 25 °C  
— 150 °C

**figure 20.** FWD

Typical peak reverse recovery current as a function of turn off gate resistor

$$I_{RM} = f(R_{goff})$$

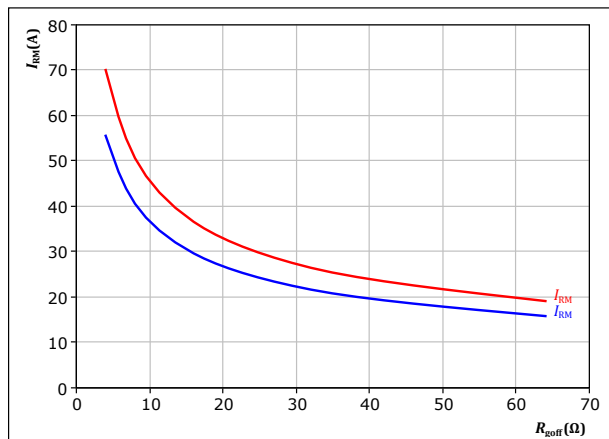

With an inductive load at

$V_{CE} = 300$  V  
 $V_{GE} = \pm 15$  V  
 $I_c = 30$  A

$T_j$ : — 25 °C  
— 150 °C



## Inverter Switching Characteristics

**figure 21.** FWD

Typical rate of fall of forward and reverse recovery current as a function of collector current  
 $di_f/dt, di_r/dt = f(I_c)$

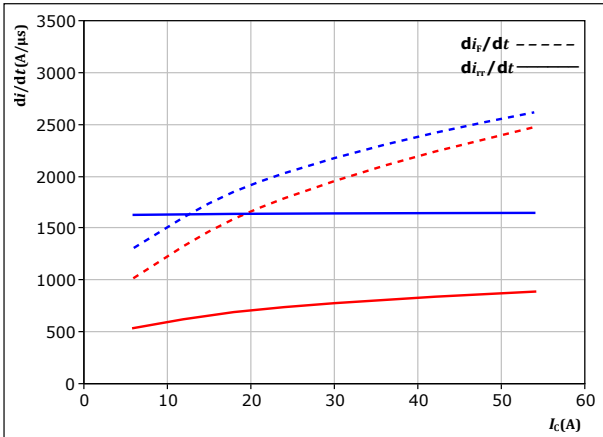

With an inductive load at

$V_{CE} = 300 \text{ V}$   
 $V_{GE} = \pm 15 \text{ V}$   
 $R_{goff} = 16 \text{ } \Omega$

$T_j$ : — 25 °C  
 — 150 °C

**figure 22.** FWD

Typical rate of fall of forward and reverse recovery current as a function of turn off gate resistor  
 $di_f/dt, di_r/dt = f(R_{goff})$

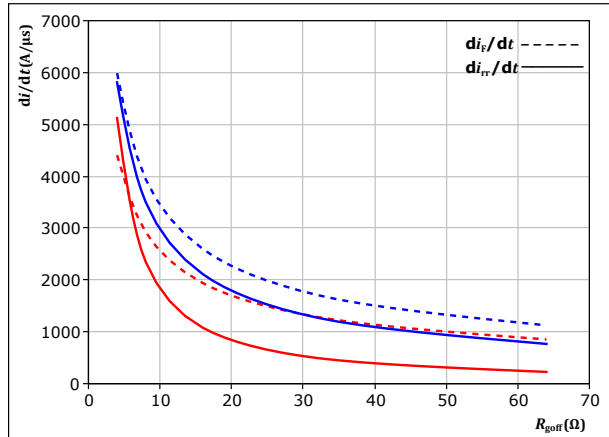

With an inductive load at

$V_{CE} = 300 \text{ V}$   
 $V_{GE} = \pm 15 \text{ V}$   
 $I_c = 30 \text{ A}$

$T_j$ : — 25 °C  
 — 150 °C

**figure 23.** IGBT

Reverse bias safe operating area

$I_c = f(V_{CE})$

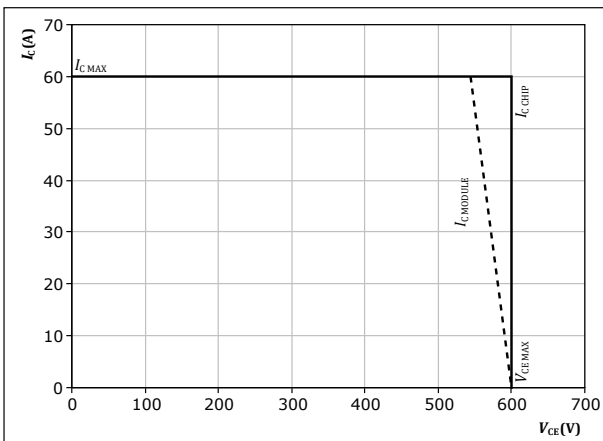

At  $T_j = 150 \text{ } ^\circ\text{C}$   
 $R_{goff} = 16 \text{ } \Omega$   
 $R_{goff} = 16 \text{ } \Omega$



## Inverter Switching Definitions

**figure 24.** IGBT  
Turn-off Switching Waveforms & definition of  $t_{doff}$ ,  $t_{Eoff}$  ( $t_{Eoff}$  = integrating time for  $E_{off}$ )

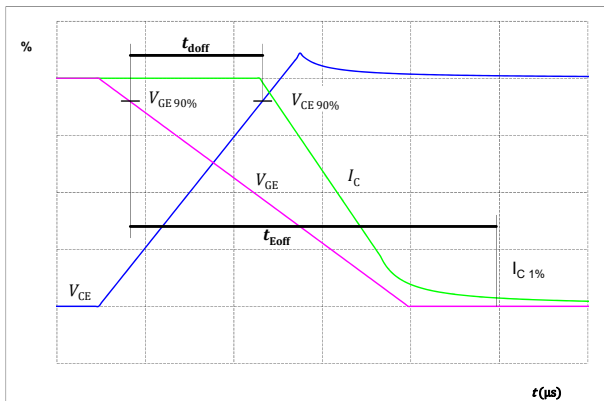

**figure 25.** IGBT  
Turn-on Switching Waveforms & definition of  $t_{don}$ ,  $t_{Eon}$  ( $t_{Eon}$  = integrating time for  $E_{on}$ )



**figure 26.** IGBT  
Turn-off Switching Waveforms & definition of  $t_f$

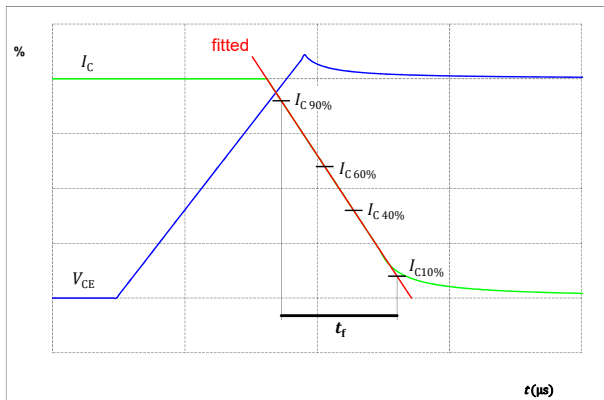

**figure 27.** IGBT  
Turn-on Switching Waveforms & definition of  $t_r$

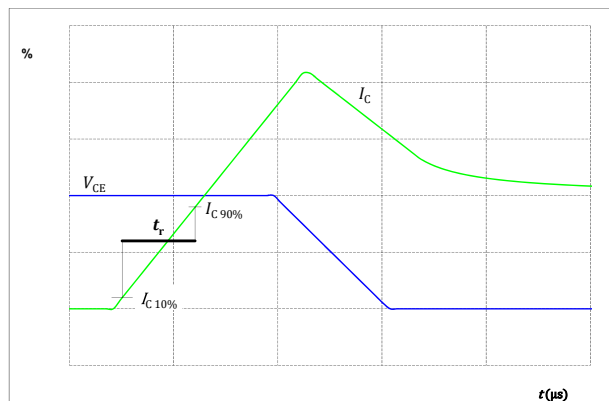



### Inverter Switching Definitions

figure 28. FWD

Turn-off Switching Waveforms & definition of  $t_{rr}$



figure 29. FWD

Turn-on Switching Waveforms & definition of  $t_{Qr}$  ( $t_{Qr}$  = integrating time for  $Q_r$ )

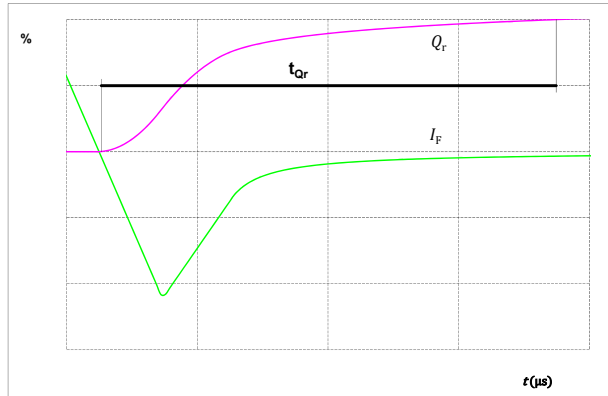



Vincotech

**10-EZ066PA030SA-L854F38T**  
datasheet

Ordering Code	
<b>Version</b>	<b>Ordering Code</b>
Without thermal paste	10-EZ066PA030SA-L854F38T
With thermal paste (3,4 W/mK, PSX-P7)	10-EZ066PA030SA-L854F38T-/3/

Marking						
	<b>Text</b>	<b>Name</b> NN-NNNNNNNNNNNNNN- TTTTTV	<b>Date code</b> WWYY	<b>UL &amp; VIN</b> UL VIN	<b>Lot</b> LLLLL	<b>Serial</b> SSSS
	<b>Datamatrix</b>	<b>Type&amp;Ver</b> TTTTTTTV	<b>Lot number</b> LLLLL	<b>Serial</b> SSSS	<b>Date code</b> WWYY	

Pin table [mm]			
Pin	X	Y	Function
1	12,8	9,6	DC+
2	16	9,6	DC+
3	22,4	9,6	Therm1
4	25,6	9,6	Therm2
5	32	9,6	DC-2
6	32	6,4	S13
7	32	3,2	DC-1
8	32	0	S11
9	28,8	0	G11
10	6,4	0	Ph1
11	3,2	0	Ph1
12	0	0	G12
13	0	6,4	G14
14	0	16	Ph2
15	0	19,2	Ph2
16	0	25,6	G16
17	3,2	25,6	Ph3
18	6,4	25,6	Ph3
19	28,8	25,6	G15
20	32	25,6	S15
21	32	22,4	DC-3
22	32	16	G13

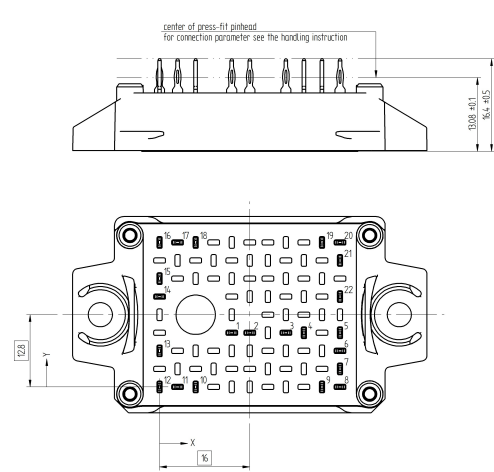

Tolerance of pinpositions: ±0,4mm at the end of pins.  
Dimension of coordinate axis is only offset without tolerance





Vincotech

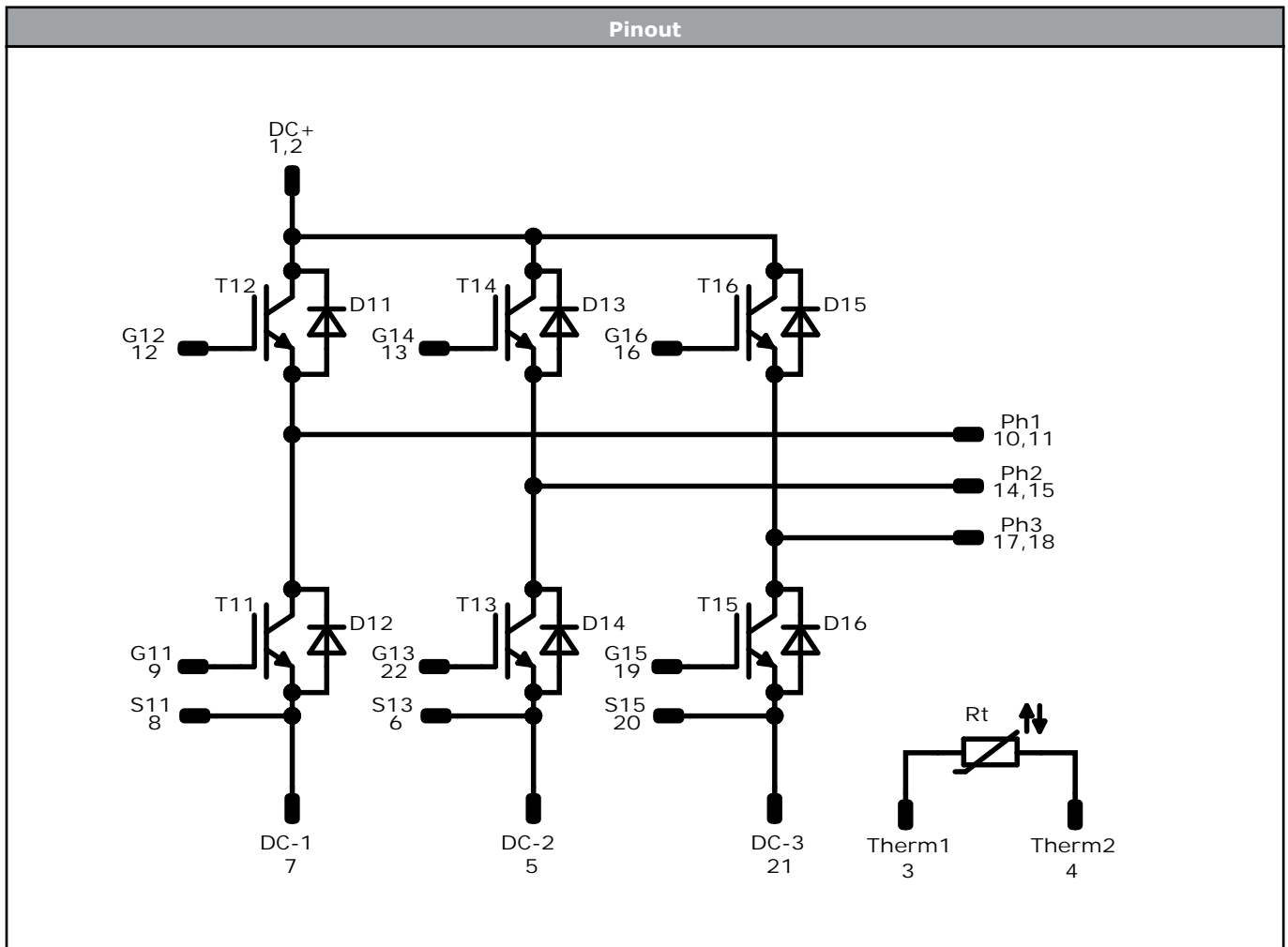

Identification					
ID	Component	Voltage	Current	Function	Comment
T11, T12, T13, T14, T15, T16	IGBT	600 V	30 A	Inverter Switch	
D11, D12, D13, D14, D15, D16	FWD	600 V	30 A	Inverter Diode	
Rt	NTC			Thermistor	



Packaging instruction				
Standard packaging quantity (SPQ) 100	>SPQ	Standard	<SPQ	Sample

Handling instruction
Handling instructions for <i>flow</i> E1 packages see vincotech.com website.

Package data
Package data for <i>flow</i> E1 packages see vincotech.com website.

Vincotech thermistor reference
See Vincotech thermistor reference table at vincotech.com website.

UL recognition and file number
This device is certified according to UL 1557 standard, UL file number E192116. For more information see vincotech.com website. 

Document No.:	Date:	Modification:	Pages
10-EZ066PA030SA-L854F38T-D3-14	29 Aug. 2021	New Datasheet format, module is unchanged Correct tau values of thermal characteristics	

**DISCLAIMER**

The information, specifications, procedures, methods and recommendations herein (together "information") are presented by Vincotech to reader in good faith, are believed to be accurate and reliable, but may well be incomplete and/or not applicable to all conditions or situations that may exist or occur. Vincotech reserves the right to make any changes without further notice to any products to improve reliability, function or design. No representation, guarantee or warranty is made to reader as to the accuracy, reliability or completeness of said information or that the application or use of any of the same will avoid hazards, accidents, losses, damages or injury of any kind to persons or property or that the same will not infringe third parties rights or give desired results. It is reader's sole responsibility to test and determine the suitability of the information and the product for reader's intended use.

**LIFE SUPPORT POLICY**

Vincotech products are not authorised for use as critical components in life support devices or systems without the express written approval of Vincotech.

As used herein:

1. Life support devices or systems are devices or systems which, (a) are intended for surgical implant into the body, or (b) support or sustain life, or (c) whose failure to perform when properly used in accordance with instructions for use provided in labelling can be reasonably expected to result in significant injury to the user.
2. A critical component is any component of a life support device or system whose failure to perform can be reasonably expected to cause the failure of the life support device or system, or to affect its safety or effectiveness.