



flowPIM E2

1200 V / 35 A

Topology features

- Converter+Inverter
- Open Emitter configuration
- Temperature sensor

Component features

- Easy paralleling
- Low turn-off losses
- Low collector emitter saturation voltage
- Positive temperature coefficient
- Short tail current
- Switching optimized for EMC

Housing features

- Base isolation: Al<sub>2</sub>O<sub>3</sub>
- Convex shaped substrate for superior thermal contact
- Compact housing
- CTI600 housing material
- Thermo-mechanical push-and-pull force relief
- Solder pin

Target applications

- Industrial Drives

Types

- 10-E212PNA035M7-L188C78Z

flow E2 12 mm housing

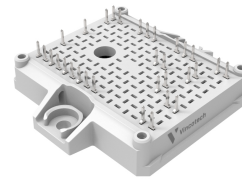

Schematic

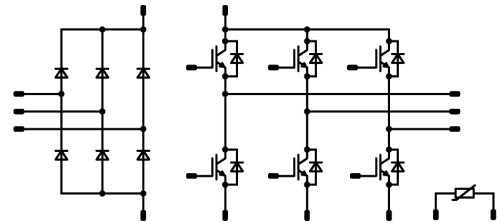



Vincotech

## Maximum Ratings

$T_j = 25\text{ °C}$ , unless otherwise specified

Parameter	Symbol	Conditions	Value	Unit
<b>Inverter Switch</b>				
Collector-emitter voltage	$V_{CES}$		1200	V
Collector current (DC current)	$I_C$	$T_j = T_{jmax}$ $T_s = 80\text{ °C}$	51	A
Repetitive peak collector current	$I_{CRM}$	$t_p$ limited by $T_{jmax}$	70	A
Total power dissipation	$P_{tot}$	$T_j = T_{jmax}$ $T_s = 80\text{ °C}$	108	W
Gate-emitter voltage	$V_{GES}$		$\pm 20$	V
Short circuit ratings	$t_{SC}$	$V_{GE} = 15\text{ V}$ , $V_{CC} = 800\text{ V}$ $T_j = 150\text{ °C}$	9,5	$\mu\text{s}$
Maximum junction temperature	$T_{jmax}$		175	$^{\circ}\text{C}$
<b>Inverter Diode</b>				
Peak repetitive reverse voltage	$V_{RRM}$		1200	V
Forward current (DC current)	$I_F$	$T_j = T_{jmax}$ $T_s = 80\text{ °C}$	41	A
Repetitive peak forward current	$I_{FRM}$	$t_p$ limited by $T_{jmax}$	70	A
Total power dissipation	$P_{tot}$	$T_j = T_{jmax}$ $T_s = 80\text{ °C}$	78	W
Maximum junction temperature	$T_{jmax}$		175	$^{\circ}\text{C}$
<b>Rectifier Diode</b>				
Peak repetitive reverse voltage	$V_{RRM}$		1600	V
Forward current (DC current)	$I_F$	$T_j = T_{jmax}$ $T_s = 80\text{ °C}$	58	A
Surge (non-repetitive) forward current	$I_{FSM}$	Single Half Sine Wave, $t_p = 10\text{ ms}$ $T_j = 150\text{ °C}$	400	A
Surge current capability	$I^2t$		800	$\text{A}^2\text{s}$
Total power dissipation	$P_{tot}$	$T_j = T_{jmax}$ $T_s = 80\text{ °C}$	68	W
Maximum junction temperature	$T_{jmax}$		150	$^{\circ}\text{C}$



Vincotech

**10-E212PNA035M7-L188C78Z**  
datasheet

## Maximum Ratings

$T_j = 25\text{ °C}$ , unless otherwise specified

Parameter	Symbol	Conditions	Value	Unit
-----------	--------	------------	-------	------

### Module Properties

#### Thermal Properties

Storage temperature	$T_{stg}$		-40...+125	°C
Operation temperature under switching condition	$T_{jop}$		-40...+( $T_{jmax} - 25$ )	°C

#### Isolation Properties

Isolation voltage	$V_{isol}$	DC Test Voltage* $t_p = 2\text{ s}$	6000	V
Isolation voltage	$V_{isol}$	AC Voltage $t_p = 1\text{ min}$	2500	V
Creepage distance			>12,7	mm
Clearance			9,11	mm
Comparative Tracking Index	CTI		≥ 600	

\*100 % tested in production



Vincotech

### Characteristic Values

Parameter	Symbol	Conditions					Values			Unit
		$V_{GS}$ [V]	$V_{GE}$ [V]	$V_{DS}$ [V]	$V_F$ [V]	$I_C$ [A] $I_D$ [A] $I_F$ [A]	$T_j$ [°C]	Min	Typ	

#### Inverter Switch

##### Static

Gate-emitter threshold voltage	$V_{GE(th)}$			10	0,0035	25	5,4	6	6,6	V
Collector-emitter saturation voltage	$V_{CE(sat)}$		15		35	25 125 150		1,47 1,64 1,68	1,85 <sup>(1)</sup>	V
Collector-emitter cut-off current	$I_{CES}$		0	1200		25			80	μA
Gate-emitter leakage current	$I_{GES}$		20	0		25			200	nA
Internal gate resistance	$r_g$							None		Ω
Input capacitance	$C_{ies}$							7900		pF
Output capacitance	$C_{oes}$		0	10		25		270		pF
Reverse transfer capacitance	$C_{res}$							97		pF
Gate charge	$Q_g$	$V_{CC} = 600$ V	0/15		35	25		260		nC

##### Thermal

Thermal resistance junction to sink <sup>(2)</sup>	$R_{th(j-s)}$	$\lambda_{paste} = 3,4$ W/mK (PSX)						0,88		K/W
--	---------------	---------------------------------------	--	--	--	--	--	------	--	-----

##### Dynamic

Turn-on delay time	$t_{d(on)}$					25 125 150		223,4 240,2 233		ns
Rise time	$t_r$					25 125 150		28 34 35,2		ns
Turn-off delay time	$t_{d(off)}$					25 125 150		227 252,2 259,4		ns
Fall time	$t_f$					25 125 150		96,87 114,26 122,62		ns
Turn-on energy (per pulse)	$E_{on}$	$Q_{tFWD} = 3,8$ μC $Q_{tFWD} = 5,84$ μC $Q_{tFWD} = 6,39$ μC				25 125 150		2,45 3,23 3,44		mWs
Turn-off energy (per pulse)	$E_{off}$					25 125 150		2,46 3,24 3,46		mWs



Vincotech

10-E212PNA035M7-L188C78Z  
datasheet

### Characteristic Values

Parameter	Symbol	Conditions					Values			Unit
		$V_{GE}$ [V] $V_{GS}$ [V]	$V_{CE}$ [V] $V_{DS}$ [V] $V_F$ [V]	$I_C$ [A] $I_D$ [A] $I_F$ [A]	$T_j$ [°C]	Min	Typ	Max		
<b>Inverter Diode</b>										
<b>Static</b>										
Forward voltage	$V_F$				35	25 125 150		1,66 1,76 1,75	2,1 <sup>(1)</sup>	V
Reverse leakage current	$I_R$	$V_r = 1200$ V				25			40	μA
<b>Thermal</b>										
Thermal resistance junction to sink <sup>(2)</sup>	$R_{th(j-s)}$	$\lambda_{paste} = 3,4$ W/mK (PSX)						1,22		K/W
<b>Dynamic</b>										
Peak recovery current	$I_{RM}$					25 125 150		41,09 40,2 40,64		A
Reverse recovery time	$t_{rr}$					25 125 150		266,56 425,38 450,01		ns
Recovered charge	$Q_r$	$di/dt=1364$ A/μs $di/dt=1192$ A/μs $di/dt=1157$ A/μs	±15	600	35	25 125 150		3,8 5,84 6,39		μC
Reverse recovered energy	$E_{rec}$					25 125 150		1,48 2,39 2,6		mWs
Peak rate of fall of recovery current	$(di_r/dt)_{max}$					25 125 150		485,16 353,08 342,83		A/μs



Vincotech

### Characteristic Values

Parameter	Symbol	Conditions					Values			Unit
		$V_{GE}$ [V] $V_{GS}$ [V]	$V_{CE}$ [V] $V_{DS}$ [V] $V_F$ [V]	$I_C$ [A] $I_D$ [A] $I_F$ [A]	$T_j$ [°C]	Min	Typ	Max		

#### Rectifier Diode

##### Static

Forward voltage	$V_F$				35	25 125 150		1,09 1,02 1,02	1,5 <sup>(1)</sup>	V
Reverse leakage current	$I_R$	$V_T = 1600$ V				25 150			100 2000	μA

##### Thermal

Thermal resistance junction to sink <sup>(2)</sup>	$R_{th(j-s)}$	$\lambda_{paste} = 3,4$ W/mK (PSX)						1,03		K/W
--	---------------	---------------------------------------	--	--	--	--	--	------	--	-----

#### Thermistor

##### Static

Rated resistance	$R$					25		5		kΩ
Deviation of R100	$\Delta_{R/R}$	$R_{100} = 493$ Ω				100	-5		5	%
Power dissipation	$P$							245		mW
Power dissipation constant	$d$					25		1,4		mW/K
B-value	$B_{(25/50)}$	Tol. ±2 %						3375		K
B-value	$B_{(25/100)}$	Tol. ±2 %						3437		K
Vincotech Thermistor Reference									K	

<sup>(1)</sup> Value at chip level

<sup>(2)</sup> Only valid with pre-applied Vincotech thermal interface material.



## Inverter Switch Characteristics

**figure 1.** IGBT

Typical output characteristics

$$I_C = f(V_{CE})$$

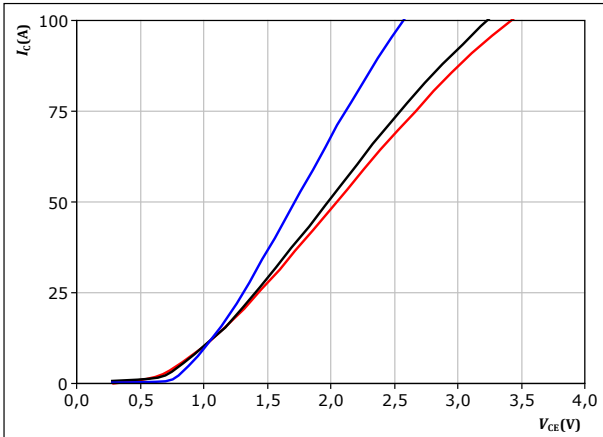

$t_p = 250 \mu s$   
 $V_{GE} = 15 V$   
 $T_j:$  — 25 °C  
— 125 °C  
— 150 °C

**figure 2.** IGBT

Typical output characteristics

$$I_C = f(V_{CE})$$

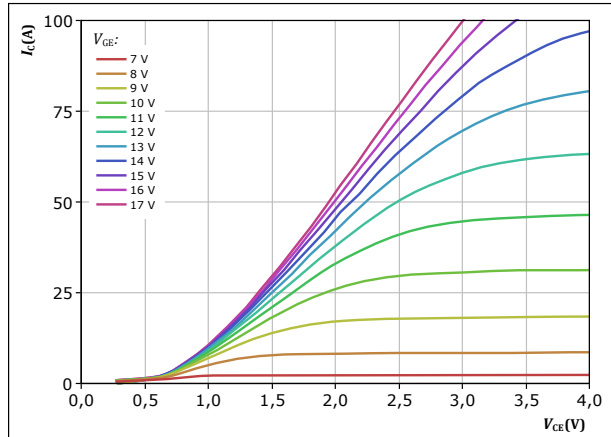

$t_p = 250 \mu s$   
 $T_j = 150 \text{ °C}$   
 $V_{GE}$  from 7 V to 17 V in steps of 1 V

**figure 3.** IGBT

Typical transfer characteristics

$$I_C = f(V_{GE})$$

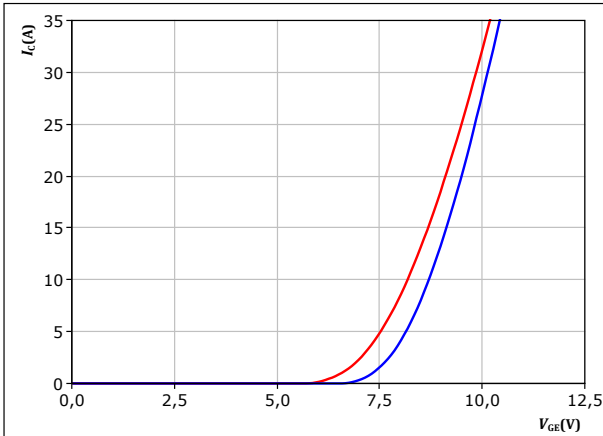

$t_p = 250 \mu s$   
 $V_{CE} = 10 V$   
 $T_j:$  — 25 °C  
— 125 °C

**figure 4.** IGBT

Transient thermal impedance as a function of pulse width

$$Z_{th(j-s)} = f(t_p)$$

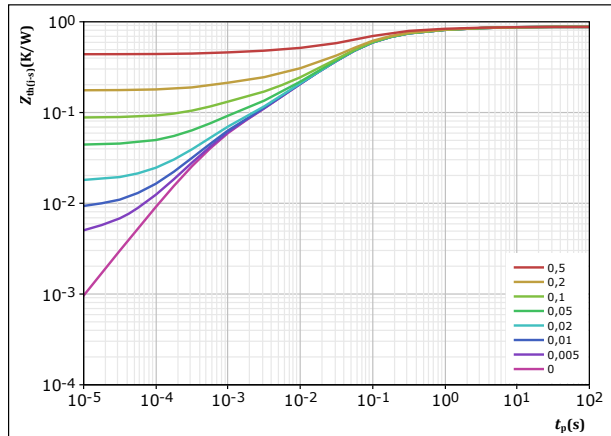

$D = t_p / T$   
 $R_{th(j-s)} = 0,878 \text{ K/W}$   
IGBT thermal model values  

R (K/W)	$\tau$ (s)
4,21E-02	5,44E+00
8,81E-02	8,75E-01
2,30E-01	1,59E-01
3,79E-01	4,61E-02
9,10E-02	6,73E-03
4,73E-02	6,45E-04



## Inverter Switch Characteristics

figure 5. IGBT

Safe operating area

$$I_C = f(V_{CE})$$

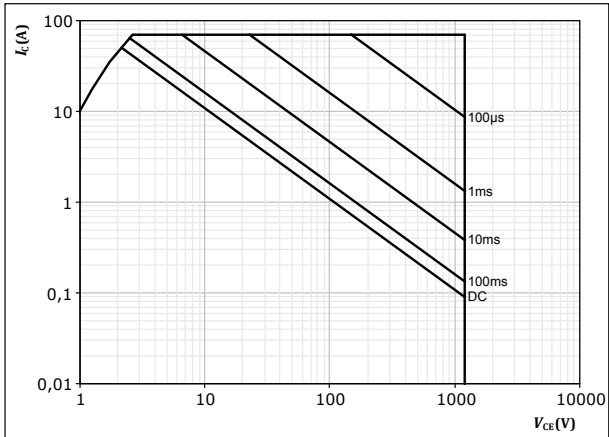

$D =$  single pulse  
 $T_s = 80 \text{ } ^\circ\text{C}$   
 $V_{GE} = 15 \text{ V}$   
 $T_j = T_{jmax}$

figure 6. IGBT

Gate voltage vs gate charge

$$V_{GE} = f(Q_g)$$

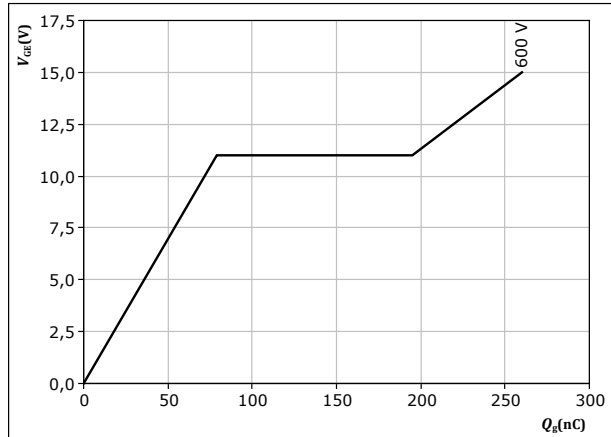

$I_C = 35 \text{ A}$   
 $T_j = 25 \text{ } ^\circ\text{C}$





### Inverter Diode Characteristics

figure 7. FWD

Typical forward characteristics

$$I_F = f(V_F)$$

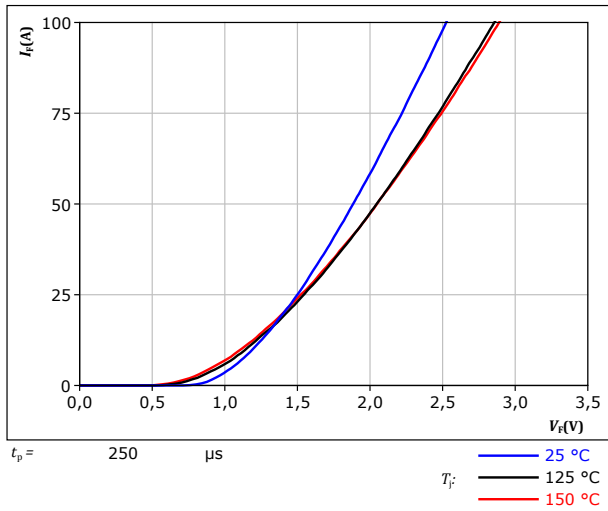
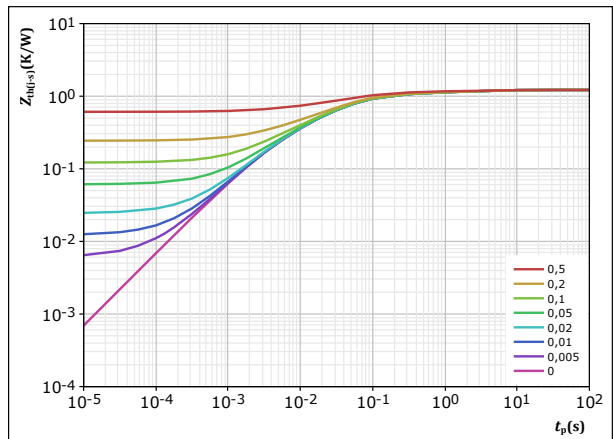

figure 8. FWD

Transient thermal impedance as a function of pulse width

$$Z_{th(j-s)} = f(t_p)$$



$D = t_p / T$   
 $R_{th(j-s)} = 1,219 \text{ K/W}$   
 FWD thermal model values

$R$ (K/W)	$\tau$ (s)
1,07E-01	3,56E+00
1,60E-01	2,77E-01
5,76E-01	5,00E-02
2,75E-01	1,24E-02
1,01E-01	2,87E-03



## Rectifier Diode Characteristics

figure 9. Rectifier

Typical forward characteristics

$$I_F = f(V_F)$$

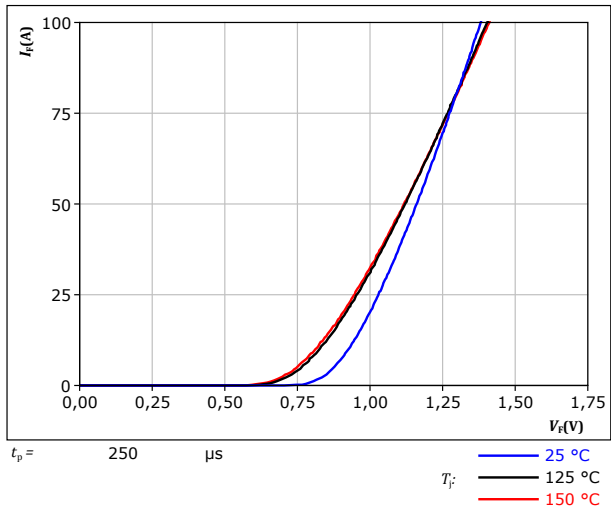
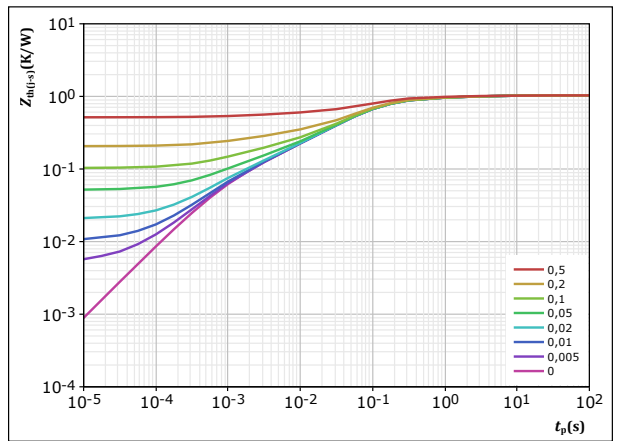

figure 10. Rectifier

Transient thermal impedance as a function of pulse width

$$Z_{th(j-s)} = f(t_p)$$



$D = \frac{t_p}{T}$   
 $R_{th(j-s)} = 1,032 \text{ K/W}$   
 Rectifier thermal model values

R (K/W)	$\tau$ (s)
4,86E-02	5,67E+00
1,31E-01	6,68E-01
5,24E-01	9,95E-02
1,97E-01	3,35E-02
8,14E-02	4,54E-03
4,98E-02	8,29E-04



## Thermistor Characteristics

figure 11. Thermistor

Typical NTC characteristic as function of temperature

$$R_T = f(T)$$

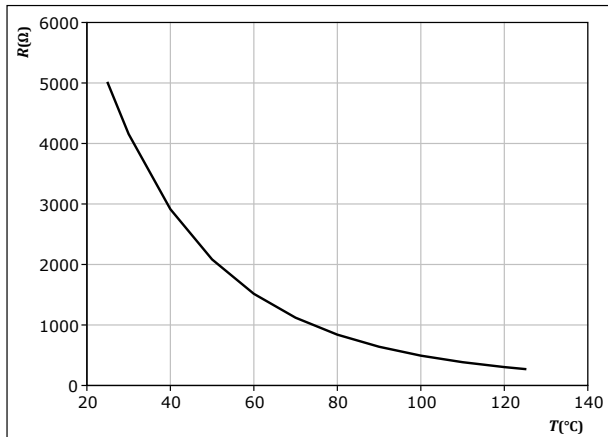



## Inverter Switching Characteristics

**figure 12.** IGBT

Typical switching energy losses as a function of collector current  
 $E = f(I_c)$

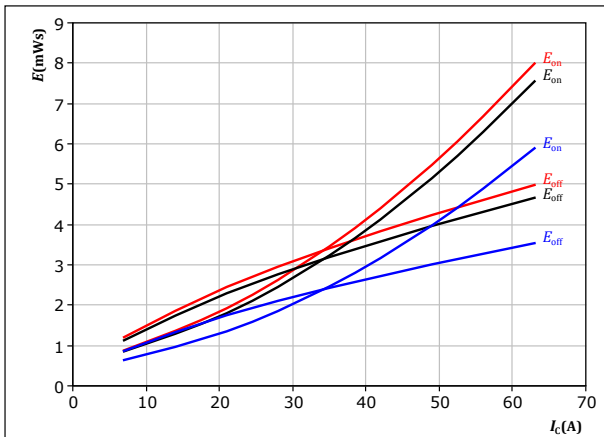

With an inductive load at  
 $V_{CE} = 600 \text{ V}$   
 $V_{GE} = \pm 15 \text{ V}$   
 $R_{gon} = 16 \text{ } \Omega$   
 $R_{goff} = 16 \text{ } \Omega$

$T_j$ : — 25 °C  
 — 125 °C  
 — 150 °C

**figure 13.** IGBT

Typical switching energy losses as a function of IGBT turn on gate resistor  
 $E = f(R_g)$

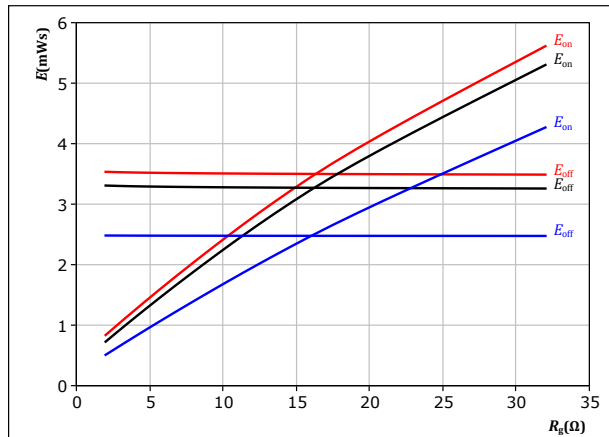

With an inductive load at  
 $V_{CE} = 600 \text{ V}$   
 $V_{GE} = \pm 15 \text{ V}$   
 $I_c = 35 \text{ A}$

$T_j$ : — 25 °C  
 — 125 °C  
 — 150 °C

**figure 14.** FWD

Typical reverse recovered energy loss as a function of collector current  
 $E_{rec} = f(I_c)$

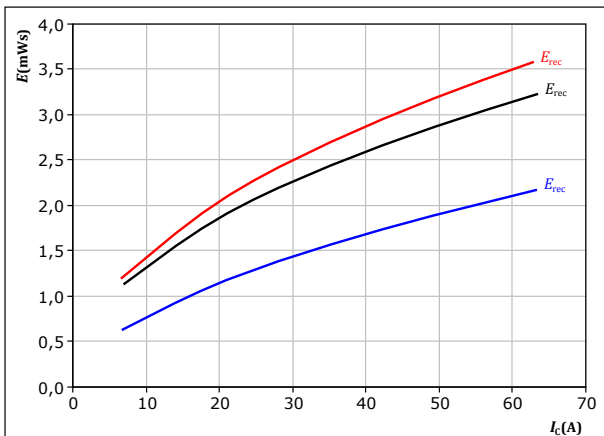

With an inductive load at  
 $V_{CE} = 600 \text{ V}$   
 $V_{GE} = \pm 15 \text{ V}$   
 $R_{gon} = 16 \text{ } \Omega$

$T_j$ : — 25 °C  
 — 125 °C  
 — 150 °C

**figure 15.** FWD

Typical reverse recovered energy loss as a function of IGBT turn on gate resistor  
 $E_{rec} = f(R_g)$

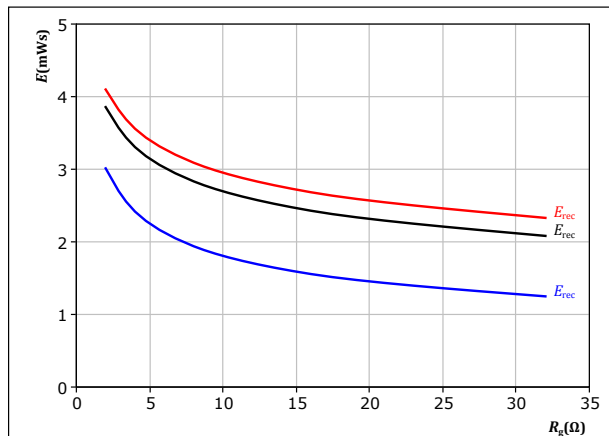

With an inductive load at  
 $V_{CE} = 600 \text{ V}$   
 $V_{GE} = \pm 15 \text{ V}$   
 $I_c = 35 \text{ A}$

$T_j$ : — 25 °C  
 — 125 °C  
 — 150 °C



## Inverter Switching Characteristics

**figure 16.** IGBT

Typical switching times as a function of collector current  
 $t = f(I_c)$

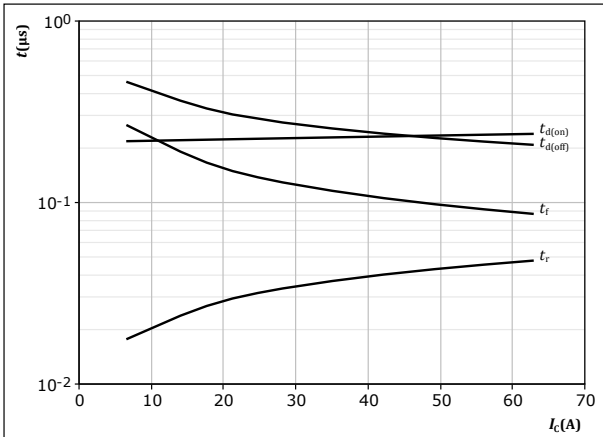

With an inductive load at  
 $T_j = 150 \text{ }^\circ\text{C}$   
 $V_{CE} = 600 \text{ V}$   
 $V_{GE} = \pm 15 \text{ V}$   
 $R_{gon} = 16 \text{ } \Omega$   
 $R_{goff} = 16 \text{ } \Omega$

**figure 17.** IGBT

Typical switching times as a function of IGBT turn on gate resistor  
 $t = f(R_g)$

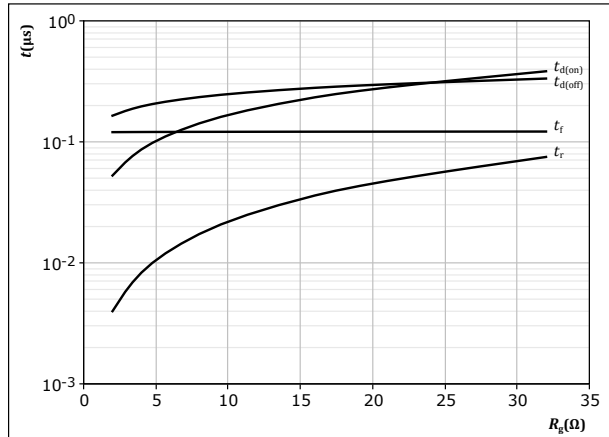

With an inductive load at  
 $T_j = 150 \text{ }^\circ\text{C}$   
 $V_{CE} = 600 \text{ V}$   
 $V_{GE} = \pm 15 \text{ V}$   
 $I_c = 35 \text{ A}$

**figure 18.** FWD

Typical reverse recovery time as a function of collector current  
 $t_{rr} = f(I_c)$

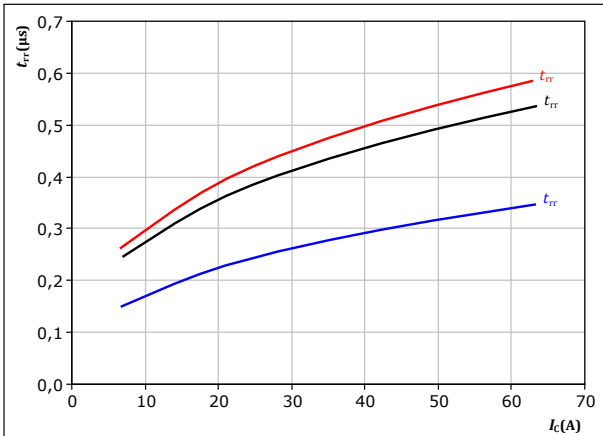

With an inductive load at  
 $V_{CE} = 600 \text{ V}$   
 $V_{GE} = \pm 15 \text{ V}$   
 $R_{gon} = 16 \text{ } \Omega$   
 $T_j:$  — 25 °C  
— 125 °C  
— 150 °C

**figure 19.** FWD

Typical reverse recovery time as a function of IGBT turn on gate resistor  
 $t_{rr} = f(R_{gon})$

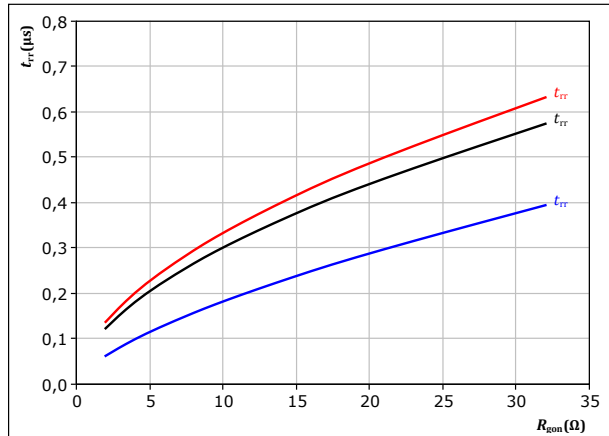

With an inductive load at  
 $V_{CE} = 600 \text{ V}$   
 $V_{GE} = \pm 15 \text{ V}$   
 $I_c = 35 \text{ A}$   
 $T_j:$  — 25 °C  
— 125 °C  
— 150 °C



## Inverter Switching Characteristics

figure 20. FWD

Typical recovered charge as a function of collector current

$$Q_r = f(I_c)$$

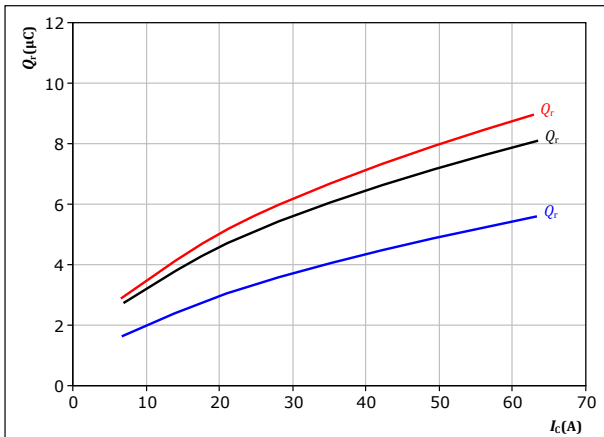

With an inductive load at

$V_{CE} = 600 \text{ V}$   
 $V_{GE} = \pm 15 \text{ V}$   
 $R_{gon} = 16 \ \Omega$

$T_j$ : — 25 °C  
 — 125 °C  
 — 150 °C

figure 21. FWD

Typical recovered charge as a function of IGBT turn on gate resistor

$$Q_r = f(R_{gon})$$

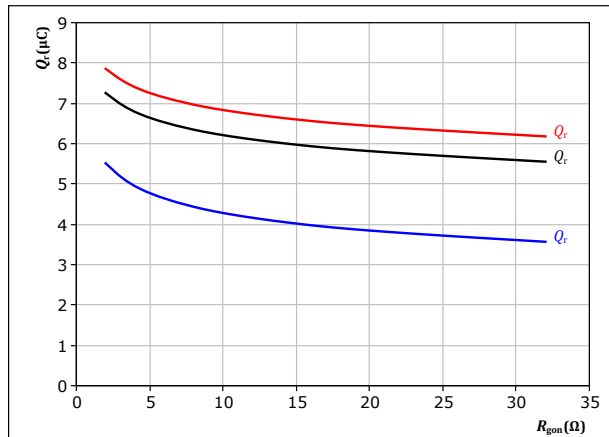

With an inductive load at

$V_{CE} = 600 \text{ V}$   
 $V_{GE} = \pm 15 \text{ V}$   
 $I_c = 35 \text{ A}$

$T_j$ : — 25 °C  
 — 125 °C  
 — 150 °C

figure 22. FWD

Typical peak reverse recovery current as a function of collector current

$$I_{RM} = f(I_c)$$

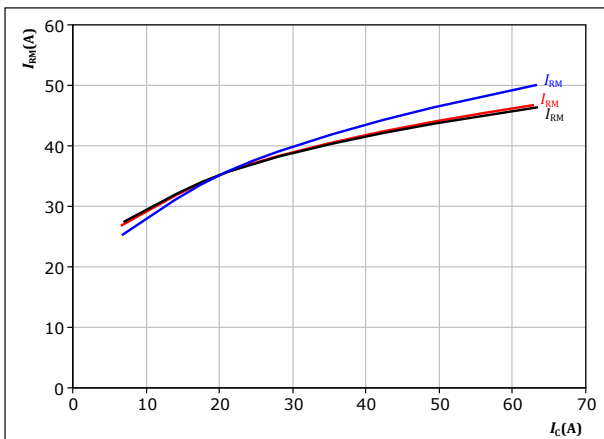

With an inductive load at

$V_{CE} = 600 \text{ V}$   
 $V_{GE} = \pm 15 \text{ V}$   
 $R_{gon} = 16 \ \Omega$

$T_j$ : — 25 °C  
 — 125 °C  
 — 150 °C

figure 23. FWD

Typical peak reverse recovery current as a function of IGBT turn on gate resistor

$$I_{RM} = f(R_{gon})$$

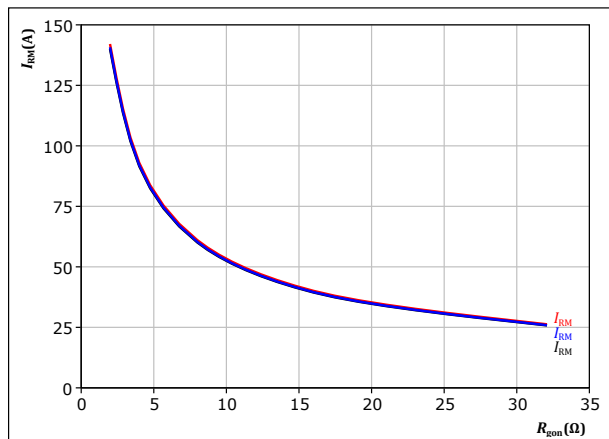

With an inductive load at

$V_{CE} = 600 \text{ V}$   
 $V_{GE} = \pm 15 \text{ V}$   
 $I_c = 35 \text{ A}$

$T_j$ : — 25 °C  
 — 125 °C  
 — 150 °C



## Inverter Switching Characteristics

**figure 24.** FWD

Typical rate of fall of forward and reverse recovery current as a function of collector current  
 $di_f/dt, di_{rr}/dt = f(I_c)$

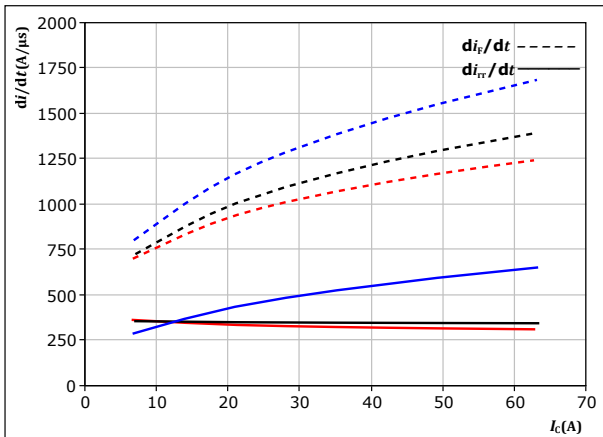

With an inductive load at

$V_{CE} = 600 \text{ V}$	$T_f = 25 \text{ }^\circ\text{C}$
$V_{GE} = \pm 15 \text{ V}$	$T_f = 125 \text{ }^\circ\text{C}$
$R_{gon} = 16 \text{ } \Omega$	$T_f = 150 \text{ }^\circ\text{C}$

**figure 25.** FWD

Typical rate of fall of forward and reverse recovery current as a function of turn on gate resistor  
 $di_f/dt, di_{rr}/dt = f(R_{gon})$

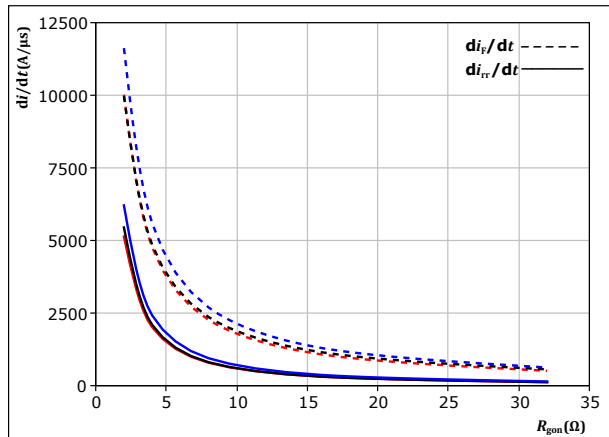

With an inductive load at

$V_{CE} = 600 \text{ V}$	$T_f = 25 \text{ }^\circ\text{C}$
$V_{GE} = \pm 15 \text{ V}$	$T_f = 125 \text{ }^\circ\text{C}$
$I_c = 35 \text{ A}$	$T_f = 150 \text{ }^\circ\text{C}$

**figure 26.** IGBT

Reverse bias safe operating area  
 $I_c = f(V_{CE})$

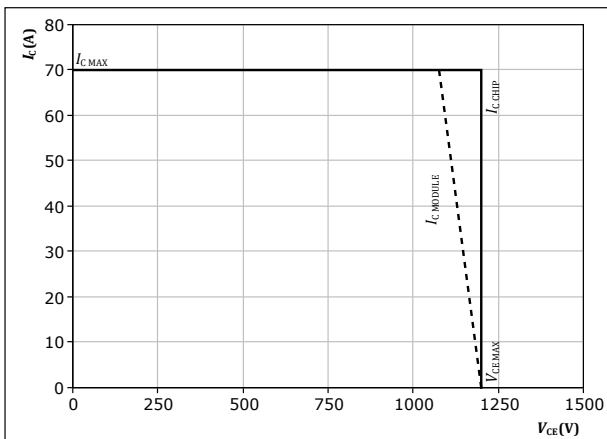

At  $T_f = 150 \text{ }^\circ\text{C}$   
 $R_{gon} = 16 \text{ } \Omega$   
 $R_{goff} = 16 \text{ } \Omega$



## Inverter Switching Definitions

**figure 27.** IGBT  
Turn-off Switching Waveforms & definition of  $t_{doff}$ ,  $t_{Eoff}$  ( $t_{Eoff}$  = integrating time for  $E_{off}$ )

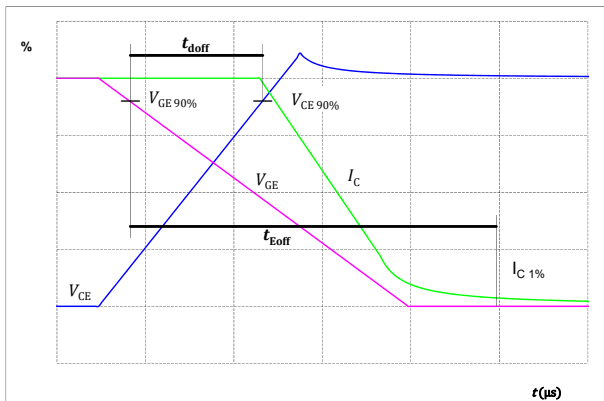

**figure 28.** IGBT  
Turn-on Switching Waveforms & definition of  $t_{don}$ ,  $t_{Eon}$  ( $t_{Eon}$  = integrating time for  $E_{on}$ )

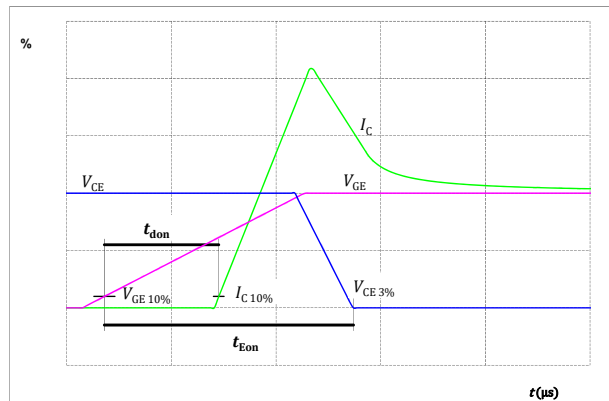

**figure 29.** IGBT  
Turn-off Switching Waveforms & definition of  $t_f$

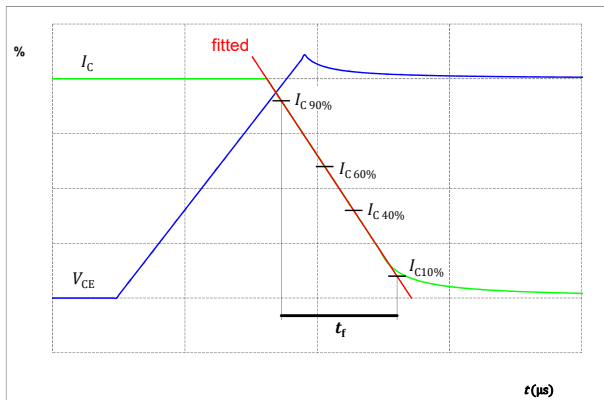

**figure 30.** IGBT  
Turn-on Switching Waveforms & definition of  $t_r$

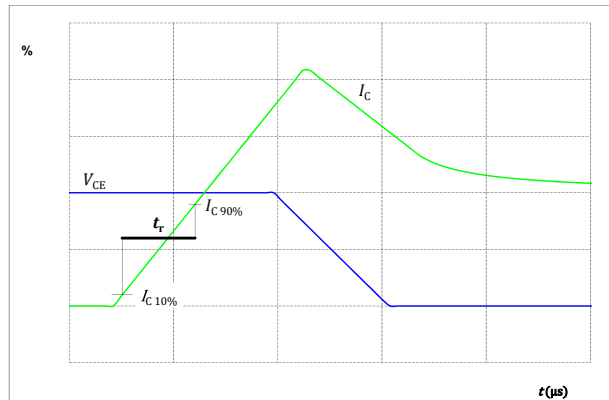





## Inverter Switching Definitions

figure 31. FWD

Turn-off Switching Waveforms & definition of  $t_{rr}$

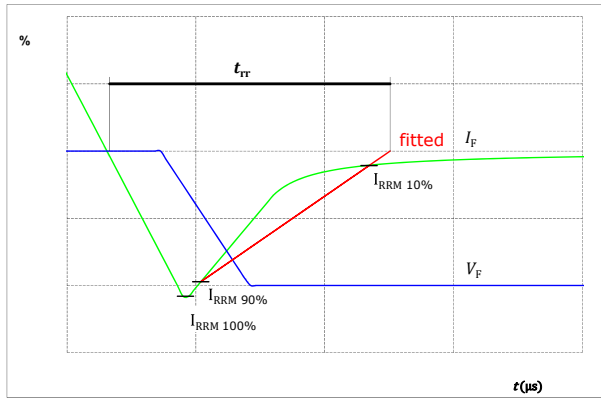
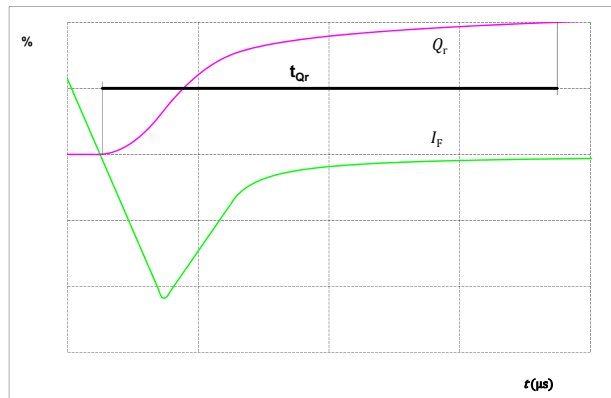

figure 32. FWD

Turn-on Switching Waveforms & definition of  $t_{Qr}$  ( $t_{Qr}$  = integrating time for  $Q_r$ )





Vincotech

**10-E212PNA035M7-L188C78Z**  
datasheet

Ordering Code	
<b>Version</b>	<b>Ordering Code</b>
Without thermal paste	10-E212PNA035M7-L188C78Z
With thermal paste (5,2 W/mK, PTM6000HV)	10-E212PNA035M7-L188C78Z-/7/
With thermal paste (3,4 W/mK, PSX-P7)	10-E212PNA035M7-L188C78Z-/3/

Marking						
	<b>Text</b>	<b>Name</b> NN-NNNNNNNNNNNNN- TTTTTIVV	<b>Date code</b> WWYY	<b>UL &amp; VIN</b> UL VIN	<b>Lot</b> LLLLL	<b>Serial</b> SSSS
	<b>Datamatrix</b>	<b>Type&amp;Ver</b> TTTTTIVV	<b>Lot number</b> LLLLL	<b>Serial</b> SSSS	<b>Date code</b> WWYY	

Outline			
Pin table [mm]			
Pin	X	Y	Function
1	25,6	6,4	ACIn2
2	22,4	6,4	ACIn2
3	16	9,6	ACIn1
4	12,8	9,6	ACIn1
5	9,6	0	DC+Rect
6	9,6	3,2	DC+Rect
7	0	0	DC-Rect
8	0	3,2	DC-Rect
9	not assembled		
10	not assembled		
11	0	22,4	G11
12	0	25,6	DC-1
13	0	28,8	DC-1
14	0	32	G13
15	0	35,2	DC-2
16	0	38,4	DC-2
17	0	41,6	G15
18	0	44,8	DC-3
19	0	48	DC-3
20	9,6	48	Therm1
21	19,2	48	Therm2
22	28,8	48	G16
23	32	48	Ph3
24	32	44,8	Ph3
25	32	35,2	G14
26	32	32	Ph2
27	32	28,8	Ph2
28	32	19,2	G12
29	32	16	Ph1
30	32	12,8	Ph1
31	32	3,2	ACIn3
32	32	0	ACIn3
33	22,4	19,2	DC+Inv
34	22,4	16	DC+Inv
35	not assembled		

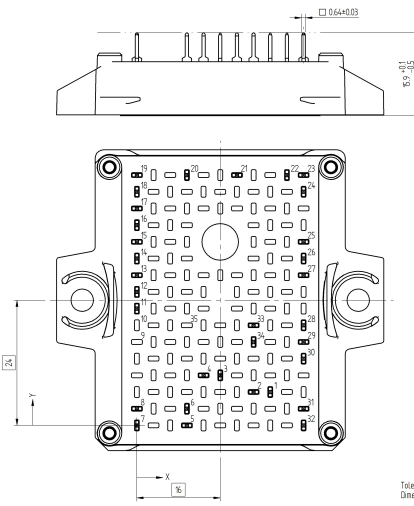

Tolerance of positions: ±0.4mm at the end of pins  
Dimension of coordinate axis is only offset without tolerance



Vincotech

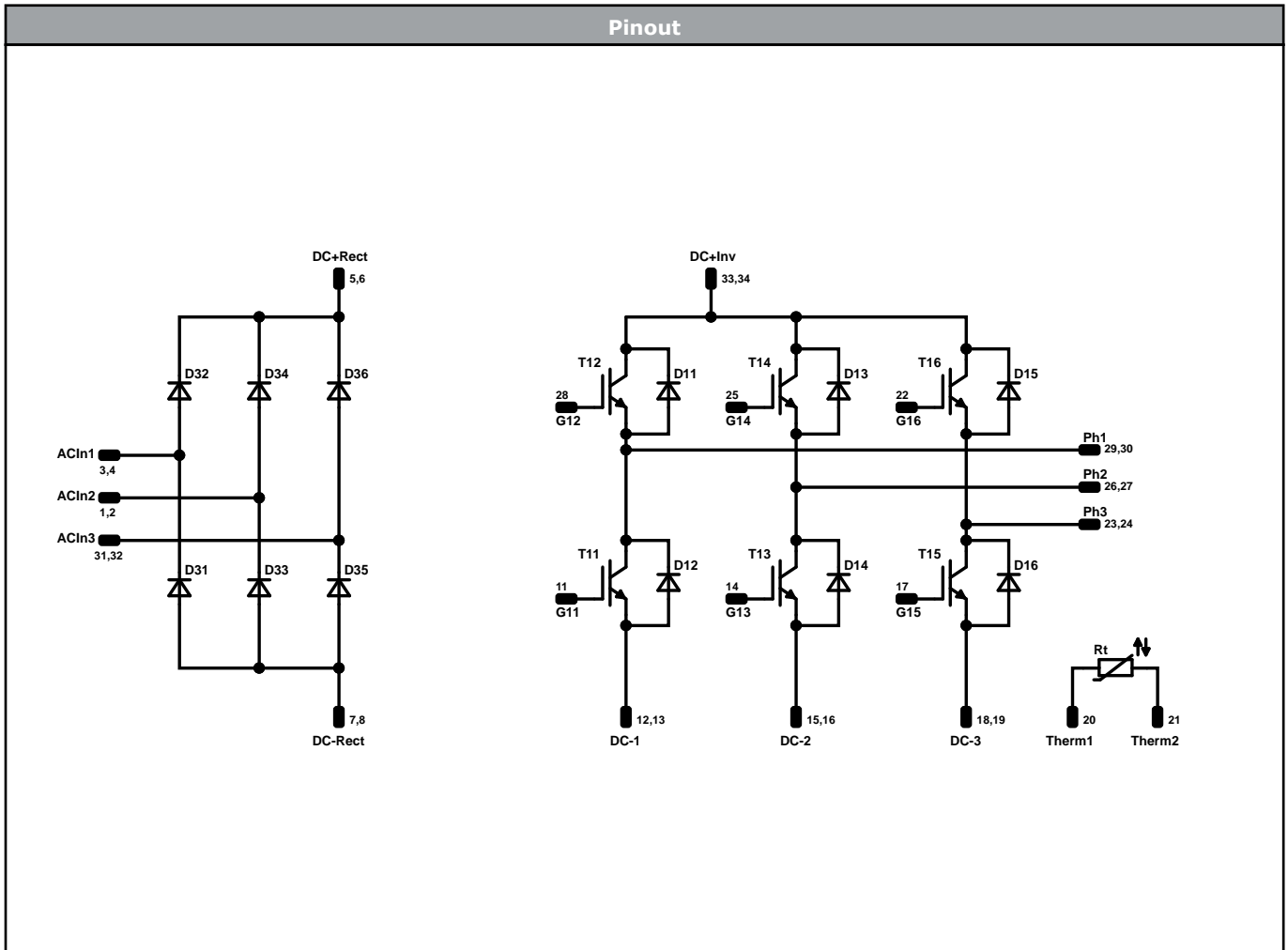

Identification					
ID	Component	Voltage	Current	Function	Comment
T11, T12, T13, T14, T15, T16	IGBT	1200 V	35 A	Inverter Switch	
D11, D12, D13, D14, D15, D16	FWD	1200 V	35 A	Inverter Diode	
D31, D32, D33, D34, D35, D36	Rectifier	1600 V	35 A	Rectifier Diode	
Rt	NTC			Thermistor	



Vincotech

Packaging instruction				
Standard packaging quantity (SPQ) 100	>SPQ	Standard	<SPQ	Sample

Handling instruction
Handling instructions for <i>flow</i> E2 packages see vincotech.com website.

Package data
Package data for <i>flow</i> E2 packages see vincotech.com website.

Vincotech thermistor reference
See Vincotech thermistor reference table at vincotech.com website.

UL recognition and file number
This device is certified according to UL 1557 standard, UL file number E192116. For more information see vincotech.com website. 

Document No.:	Date:	Modification:	Pages
10-E212PNA035M7-L188C78Z-D2-14	9 Jun. 2023	Correct construction cover page	

**DISCLAIMER**

The information, specifications, procedures, methods and recommendations herein (together "information") are presented by Vincotech to reader in good faith, are believed to be accurate and reliable, but may well be incomplete and/or not applicable to all conditions or situations that may exist or occur. Vincotech reserves the right to make any changes without further notice to any products to improve reliability, function or design. No representation, guarantee or warranty is made to reader as to the accuracy, reliability or completeness of said information or that the application or use of any of the same will avoid hazards, accidents, losses, damages or injury of any kind to persons or property or that the same will not infringe third parties rights or give desired results. It is reader's sole responsibility to test and determine the suitability of the information and the product for reader's intended use.

**LIFE SUPPORT POLICY**

Vincotech products are not authorised for use as critical components in life support devices or systems without the express written approval of Vincotech.

As used herein:

1. Life support devices or systems are devices or systems which, (a) are intended for surgical implant into the body, or (b) support or sustain life, or (c) whose failure to perform when properly used in accordance with instructions for use provided in labelling can be reasonably expected to result in significant injury to the user.
2. A critical component is any component of a life support device or system whose failure to perform can be reasonably expected to cause the failure of the life support device or system, or to affect its safety or effectiveness.