

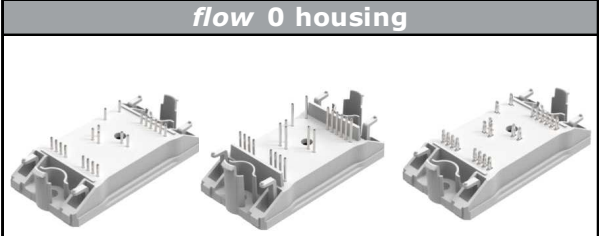
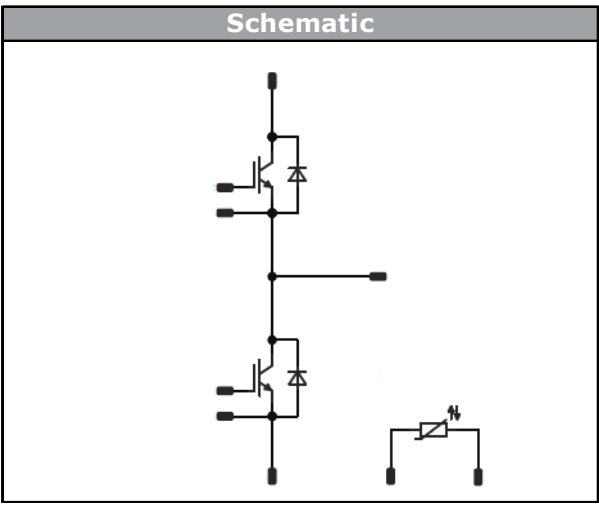

Vincotech

10-FZ122PB100SC02-M819F08
10-F0122PB100SC02-M819F09
10-PZ122PB100SC02-M819F08Y
 target datasheet

<i>flow</i> PHASE 0	1200 V / 100 A
<div style="background-color: #eee; padding: 5px; margin-bottom: 5px;">Features</div> <ul style="list-style-type: none"> High efficiency IGBT4 half-bridge Full current FWD Improved R_{th} with AlN DCB Thermistor <div style="background-color: #eee; padding: 5px; margin-bottom: 5px;">Target applications</div> <ul style="list-style-type: none"> Industrial Drives Power Supply Solar UPS Welding <div style="background-color: #eee; padding: 5px;">Types</div> <ul style="list-style-type: none"> 10-FZ122PB100SC03-M819F18 10-F0122PB100SC03-M819F19 10-PZ122PB100SC03-M819F18Y 	<div style="background-color: #eee; padding: 5px; margin-bottom: 5px;">flow 0 housing</div> <div style="text-align: center;">  </div> <div style="display: flex; justify-content: space-around; font-size: small;"> 12 mm housing 17 mm housing Press-fit pins </div> <div style="background-color: #eee; padding: 5px; margin-top: 10px;">Schematic</div> <div style="text-align: center;">  </div>

Maximum Ratings

$T_j=25^{\circ}\text{C}$, unless otherwise specified

Parameter	Symbol	Condition	Value	Unit
Half-bridge Switch				
Collector-emitter voltage	V_{CES}		1200	V
Collector current	I_C	$T_j = T_{jmax}$ $T_s = 80^{\circ}\text{C}$	90	A
Repetitive peak collector current	I_{CRM}	t_p limited by T_{jmax}	300	A
Total power dissipation	P_{tot}	$T_j = T_{jmax}$ $T_s = 80^{\circ}\text{C}$	207	W
Gate-emitter voltage	V_{GES}		± 20	V
Short circuit ratings	t_{SC}	$T_j \leq 150^{\circ}\text{C}$	10	μs
	V_{CC}	$V_{GE} = 15\text{V}$	800	V
Maximum Junction Temperature	T_{jmax}		175	$^{\circ}\text{C}$



Vincotech

10-FZ122PB100SC02-M819F08
10-F0122PB100SC02-M819F09
10-PZ122PB100SC02-M819F08Y
target datasheet

Parameter	Symbol	Conditions	Value	Unit
Half-bridge Diode				
Peak Repetitive Reverse Voltage	V_{RRM}		1200	V
Continuous (direct) forward current	I_F	$T_j = T_{jmax}$ $T_s = 80^\circ\text{C}$	84	A
Repetitive peak forward current	I_{FRM}		200	A
Total power dissipation	P_{tot}	$T_j = T_{jmax}$ $T_s = 80^\circ\text{C}$	144	W
Maximum Junction Temperature	T_{jmax}		175	$^\circ\text{C}$

Module Properties

Parameter	Symbol	Conditions	Value	Unit
-----------	--------	------------	-------	------

Thermal Properties

Storage temperature	T_{stg}		-40...+125	$^\circ\text{C}$
Operation Junction Temperature	T_{jop}		-40...+($T_{jmax} - 25$)	$^\circ\text{C}$

Isolation Properties

Isolation voltage	V_{isol}	DC voltage	4000	V
Creepage distance			min 12,7	mm
Clearance		for 12 mm housing	9,12	mm
Clearance		for 17 mm housing	min 12,7	mm
Clearance		for Press-fit pins	9,54	mm
Comparative Tracking Index	CTI		>200	



Vincotech

10-FZ122PB100SC02-M819F08
10-F0122PB100SC02-M819F09
10-PZ122PB100SC02-M819F08Y
 target datasheet

Characteristic Values

Half-bridge Switch

Parameter	Symbol	Conditions					Value			Unit
		V_{GE} [V]	V_{CE} [V]	I_C [A]	T_j [°C]	Min	Typ	Max		

Static

Gate-emitter threshold voltage	$V_{GE(th)}$	$V_{GE}=V_{CE}$			0,0038	25 125	5,1	5,8	6,4	V
Collector-emitter saturation voltage	V_{CEsat}		15		100	25 125 150	1,53	1,90	2,1	V
Collector-emitter cut-off current	I_{CES}		0	1200		25 125			10	μA
Gate-emitter leakage current	I_{GES}		20	0		25 125			120	nA
Internal gate resistance	r_g							7,5		Ω
Input capacitance	C_{ies}	f=1 MHz	0	25		25		6300		pF
Reverse transfer capacitance	C_{res}							270		

Thermal

Thermal resistance junction to sink	$R_{th(j-s)}$	phase-change material $\lambda=3,4W/mK$							0,46		K/W
-------------------------------------	---------------	--	--	--	--	--	--	--	------	--	-----

Half-bridge Diode

Parameter	Symbol	Conditions					Value			Unit
		V_r [V]	I_F [A]	T_j [°C]	Min	Typ	Max			

Static

Forward voltage	V_F				100	25 125	1,35	1,83 1,86	2,05	V
Reverse leakage current	I_r			1200		25 150			18	μA

Thermal

Thermal resistance junction to sink	$R_{th(j-s)}$	phase-change material $\lambda=3,4W/mK$							0,66		K/W
-------------------------------------	---------------	--	--	--	--	--	--	--	------	--	-----



Vincotech

10-FZ122PB100SC02-M819F08
10-F0122PB100SC02-M819F09
10-PZ122PB100SC02-M819F08Y
target datasheet

Thermistor

Parameter	Symbol	Conditions					Value			Unit
		V_{GE} [V]	V_{CE} [V]	I_C [A]	T_j [°C]	Min	Typ	Max		
Rated resistance	R				25		21,5		kΩ	
Deviation of R100	$\Delta_{R/R}$	R100=1486 Ω			100	-4,5		+4,5	%	
Power dissipation	P				25		210		mW	
Power dissipation constant					25		3,5		mW/K	
B-value	$B_{(25/50)}$				25		3884		K	
B-value	$B_{(25/100)}$				25		3964		K	
Vincotech NTC Reference								F		



Vincotech

10-FZ122PB100SC02-M819F08
10-F0122PB100SC02-M819F09
10-PZ122PB100SC02-M819F08Y
 target datasheet

Ordering Code & Marking							
Version	Ordering Code	in DataMatrix as		in packaging barcode as			
without thermal paste 12mm housing	10-FZ122PB100SC02-M819F08	M819F08		M819F08			
without thermal paste 17mm housing	10-F0122PB100SC02-M819F09	M819F09		M819F09			
NN-NNNNNNNNNNNNNN NNNNNNNN WWYY UL Vinco LLLLL SSSS		Text	Name	Date code	UL & Vinco	Lot	Serial
			NN-NNNNNNNNNNNNNN-NNNNNNNN	WWYY	UL Vinco	LLLLL	SSSS
		Datamatrix	Type&Ver	Lot number	Serial	Date code	
		TTTTTTTV	LLLLL	SSSS	WWYY		

Pin table [mm]				Outline	
Pin	X	Y	Function		
1	0	0	DC-		12 mm housing
2	0	2,3	DC-		
3	0	4,6	DC-		
4	0	6,9	DC-		
5	0	15,6	DC+		
6	0	17,9	DC+		
7	0	20,2	DC+		
8	0	22,5	DC+		
9	13,85	16,45	G12		17 mm housing
10	16,75	16,45	S12		
11	33,5	11,5	Ph		
12	33,5	9,2	Ph		
13	33,5	6,9	Ph		
14	33,5	4,6	Ph		
15	33,5	2,3	Ph		
16	33,5	0	Ph		
17	13,85	13,55	Ph		
18	19,55	4,95	S11		
19	19,55	7,85	G11		
20	33,5	22,5	Therm1		Tolerance of positions: $\pm 0,5$ mm of the end of pins Dimension of coordinate axis is only offset without tolerance
21	26,1	22,5	Therm2		



Vincotech

10-FZ122PB100SC02-M819F08
10-F0122PB100SC02-M819F09
10-PZ122PB100SC02-M819F08Y
 target datasheet

Ordering Code & Marking								
Version	Ordering Code	in DataMatrix as		in packaging barcode as				
without thermal paste Press-Fit pins	10-PZ122PB100SC02-M819F08Y	M819F08Y		M819F08Y				
NN-NNNNNNNNNNNNNN NNNNNNNN WWYY UL Vinco LLLLL SSSS		Text	Name		Date code	UL & Vinco	Lot	Serial
			NN-NNNNNNNNNNNNNN-NNNNNNNN		WWYY	UL Vinco	LLLLL	SSSS
		Datamatrix	Type&Ver	Lot number	Serial	Date code		
		TTTTTTTV	LLLLL	SSSS	WWYY			

Pin table [mm]			
Pin	X	Y	Function
1	0	0	DC-
2	0	2,3	DC-
3	0	4,6	DC-
4	0	6,9	DC-
5	0	15,6	DC+
6	0	17,9	DC+
7	0	20,2	DC+
8	0	22,5	DC+
9	13,85	16,45	G12
10	16,75	16,45	S12
11	33,5	11,5	Ph
12	33,5	9,2	Ph
13	33,5	6,9	Ph
14	33,5	4,6	Ph
15	33,5	2,3	Ph
16	33,5	0	Ph
17	13,85	13,55	Ph
18	19,55	4,95	S11
19	19,55	7,85	G11
20	33,5	22,5	Therm1
21	26,1	22,5	Therm2

Tolerance of pinpositions: ±0,5mm at the end of pins
 Dimension of coordinate axis is only offset without tolerance



Vincotech

10-FZ122PB100SC02-M819F08
10-F0122PB100SC02-M819F09
10-PZ122PB100SC02-M819F08Y
 target datasheet

Pinout

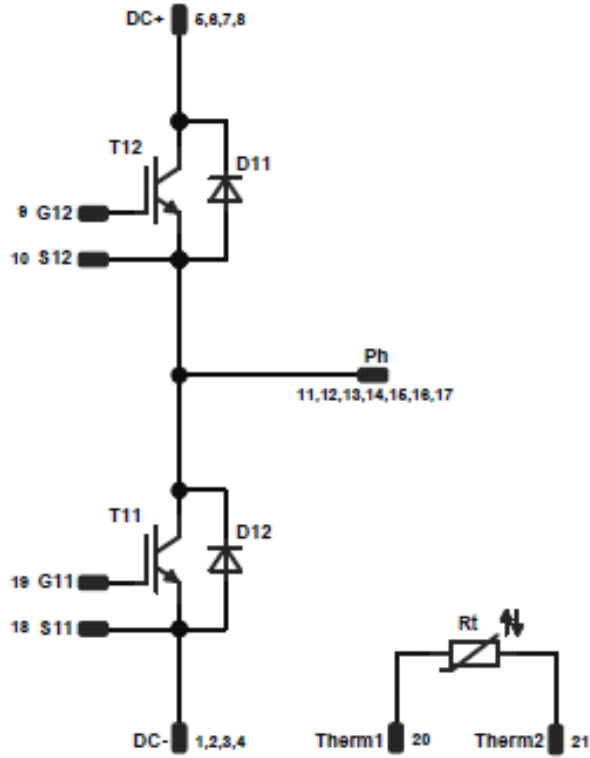

Identification

ID	Component	Voltage	Current	Function	Comment
T11, T12	IGBT	1200V	100A	Half-bridge Switch	
D11, D12	FWD	1200V	100A	Half-bridge Diode	
Rt	NTC	-	-	Thermistor	



Packaging instruction			
Standard packaging quantity (SPQ)	135	>SPQ	Standard
		<SPQ	Sample

Handling instruction
Handling instructions for <i>flow</i> 0 packages see vincotech.com website.

Package data
Package data for <i>flow</i> 0 packages see vincotech.com website.

Document No.:	Date:	Modification:	Pages
10-Fx122PB100SC02-M819F0x-T2-14	25 Feb. 2017		

Product status definition		
Datasheet Status	Product Status	Definition
Target	Formative or In Design	This datasheet contains the design specifications for product development. Specifications may change in any manner without notice. The data contained is exclusively intended for technically trained staff.

DISCLAIMER

The information, specifications, procedures, methods and recommendations herein (together "information") are presented by Vincotech to reader in good faith, are believed to be accurate and reliable, but may well be incomplete and/or not applicable to all conditions or situations that may exist or occur. Vincotech reserves the right to make any changes without further notice to any products to improve reliability, function or design. No representation, guarantee or warranty is made to reader as to the accuracy, reliability or completeness of said information or that the application or use of any of the same will avoid hazards, accidents, losses, damages or injury of any kind to persons or property or that the same will not infringe third parties rights or give desired results. It is reader's sole responsibility to test and determine the suitability of the information and the product for reader's intended use.

LIFE SUPPORT POLICY

Vincotech products are not authorised for use as critical components in life support devices or systems without the express written approval of Vincotech.

As used herein:

1. Life support devices or systems are devices or systems which, (a) are intended for surgical implant into the body, or (b) support or sustain life, or (c) whose failure to perform when properly used in accordance with instructions for use provided in labelling can be reasonably expected to result in significant injury to the user.
2. A critical component is any component of a life support device or system whose failure to perform can be reasonably expected to cause the failure of the life support device or system, or to affect its safety or effectiveness.