



FOR IMMEDIATE RELEASE

Contacts:

Product Contact:

Michele Portico
Phone: +49 (0)89 878067-145
Michele.Portico@vincotech.com

Media Contact:

Karina Seifert
Phone: +49 (0)89 878067-115
Karina.Seifert@vincotech.com

A NEW IPM WITH CIB TOPOLOGY – FOR THE DEEPEST LEVEL OF INTEGRATION

-- Using *flowIPM 1C CIB 1200 V* drives down costs and speeds up assembly --

Unterhaching, Germany, January 16, 2017. Vincotech, a supplier of module-based solutions for power electronics, today announced the launch of a new, deeply integrated Intelligent Power Module for 1200 V applications. The *flowIPM 1C CIB 1200 V* achieves the deepest level of integration of any power module available on the market today to drive down systems' cost and speed up assembly.

The *flowIPM 1C* based on a CIB topology (converter + inverter + brake) features three inverter gate drives, including a bootstrap circuit for high-side power supply. Each leg of the inverter provides current-limiting for circuit protection.

The current rating of this new intelligent power module housed in the new *flow 1C* housing is also impressive: 14 A @ 80°C or 30 A @ 25°C heat sink temperature.

The deeply integrated ***flowIPM 1C CIB 1200 V*** module enables manufacturers to slash their overall system's size, cost, and time to market. It also features a brake chopper with integrated gate drive as well as emitter shunts (30 mΩ) for vastly improved motion control.

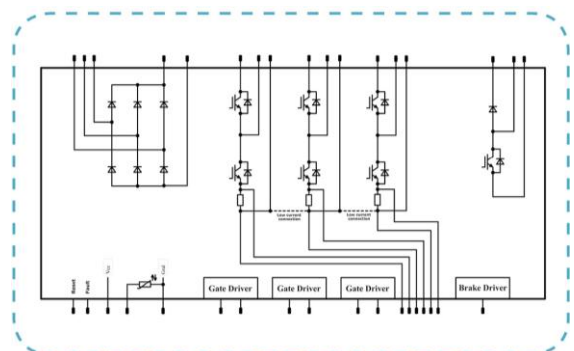

Samples may be sourced on demand from our usual channels.

To learn more about Vincotech's *flowIPM 1C CIB 1200 V*, please visit:

<http://www.vincotech.com/IPM-1C>

To see Vincotech's entire range of power modules, please visit:

<http://www.vincotech.com/products/by-topologies.html>

Vincotech is a registered trademark of Vincotech Holdings S.à.r.l.

ABOUT VINCOTECH

Vincotech – an affiliated company within the Mitsubishi Electric Corporation – develops and manufactures subsystems and electronic components and provides manufacturing services that help customers master complex challenges in electronics integration. Vincotech's extensive portfolio encompasses standard and tailored solutions, engineering services, and technical support for customers worldwide. These products and services contribute to sustainable, environmentally sound solutions that help modern society embrace mega-trends and explore new avenues.

With approximately 500 employees worldwide, backed by vast experience and a long history in electronics integration, Vincotech leverages these assets to help customers achieve maximum market success.

To learn more about Vincotech, please visit www.vincotech.com.

#