



FOR IMMEDIATE RELEASE

Contacts:

Product Contact:

Baran Özbakir
Phone: +49 (0)89 878067-144
Baran.Ozbakir@vincotech.com

Media Contact:

Karina Seifert
Phone: +49 (0)89 878067-115
Karina.Seifert@vincotech.com

THE BIDIRECTIONAL FAST-TRACK TO FULL CURRENT CAPABILITY

-- The H-bridge to up customers application's speed and efficiency

Unterhaching, Germany, September 05, 2016. Vincotech, a supplier of module-based solutions for power electronics, today announced the launch of a new *fastPACK 0 HC* improving UPS, SMPS, solar and welding applications in speed, efficiency and full-current capability for bidirectional usage. The new H-bridge module is available in the low-inductive *flow 0* housing.

The new ***fastPACK 0 HC*** module featuring high frequency 650 V IGBT H5 technology in combination with a fast diode enables outstanding efficiency, reliability and perfectly balances cost and performance. This utmost efficient H-bridge module delivers 30+ kHz fsw and is suitable for soft switching to reduce switching losses.

The ***fastPACK 0 HC*** enables bidirectional operation for charger and SMPS applications with full current FWD. It is also equipped with integrated capacitors reducing electromagnetic interference.

Packaged in the low-inductive *flow 0* 12 mm housing the module can also be provided with phase-change material on special request.

To learn more about Vincotech's *fastPACK 0 HC*, please visit: <http://www.vincotech.com/fastPACK-0-HC>

To see Vincotech's entire range of power modules, please visit: <http://www.vincotech.com/products/by-topologies.html>

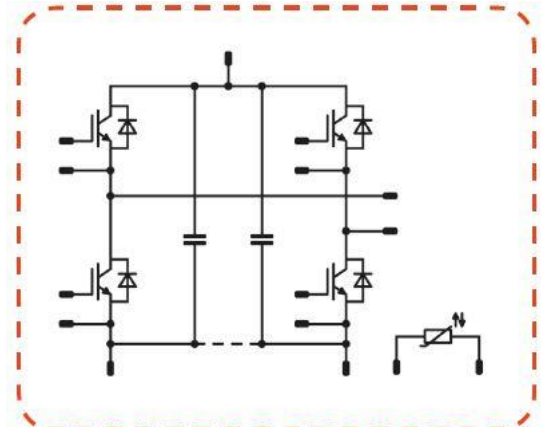
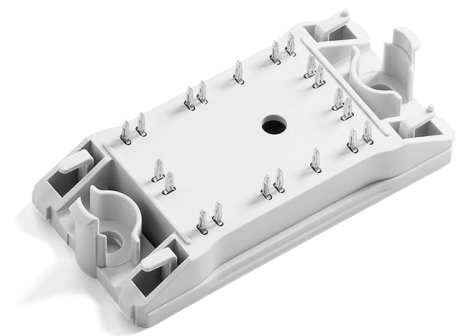

Vincotech is a registered trademark of Vincotech Holdings S.à.r.l.

ABOUT VINCOTECH

Vincotech – an affiliated company within the Mitsubishi Electric Corporation – develops and manufactures subsystems and electronic components and provides manufacturing services that help customers master complex challenges in electronics integration. Vincotech’s extensive portfolio encompasses standard and tailored solutions, engineering services, and technical support for customers worldwide. These products and services contribute to sustainable, environmentally sound solutions that help modern society embrace mega-trends and explore new avenues.

With approximately 500 employees worldwide, backed by vast experience and a long history in electronics integration, Vincotech leverages these assets to help customers achieve maximum market success.

To learn more about Vincotech, please visit www.vincotech.com.

#