



Vincotech

Reference Design for IPM Modules

Evaluation Board for P95X-A45 TF IPM Modules

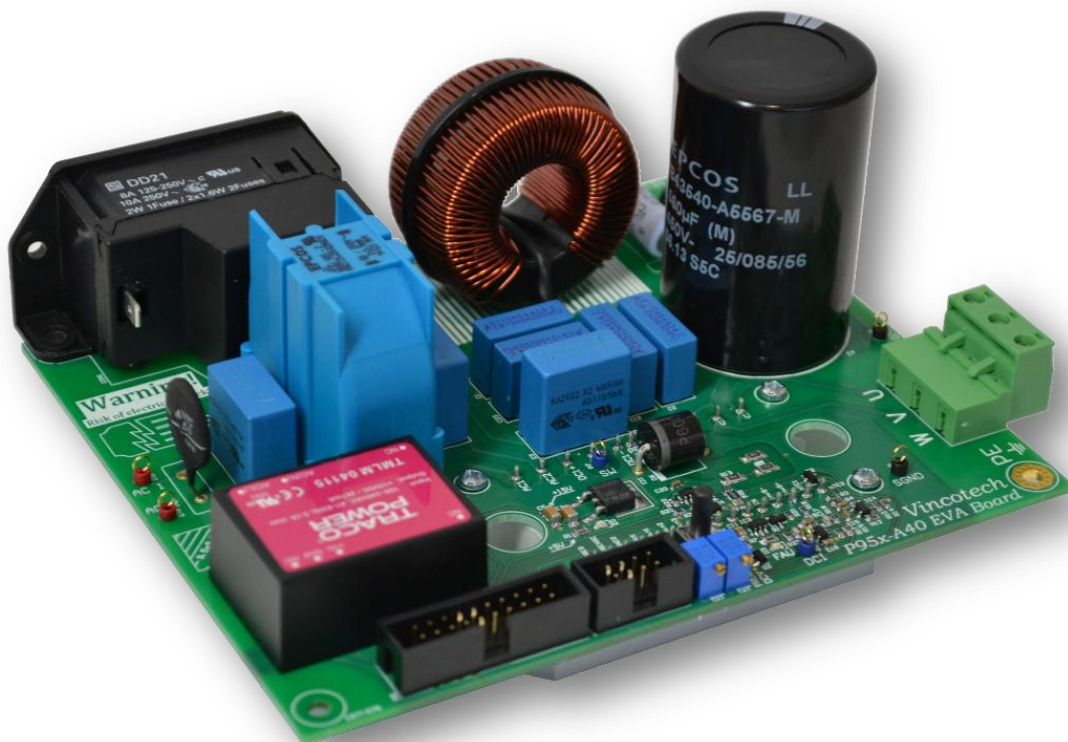



Table of Contents

1	Introduction	4
2	Features of the board	5
2.1	Main features	5
2.2	Electrical parameters	5
2.3	Pin assignments	6
2.4	Mechanical dimensions	7
3	Description of electrical parts	8
3.1	Input filter and rectification.....	9
3.2	PFC.....	9
3.3	Inverter part and shunt measurement.....	11
3.4	Voltage measurements.....	12
3.5	Temperature measurement.....	13
4	Operation	13
5	Definition of layers.....	14
6	Layout.....	15
7	Schematics	19
8	BOM.....	23



Revision History

Date	Revision Level	Description	Page Number(s)
March 2011	1	First release	22
July 2015	2	Change into new format	24

Disclaimer:

The information in this document is given as an indication for the purpose of implementation only and shall not be regarded as any description or warranty of a certain functionality, condition or quality. The statements contained herein, including any recommendation, suggestion or methodology, are to be verified by the user before implementation, as operating conditions and environmental factors may vary. It shall be the sole responsibility of the recipient of this document to verify any function described herein in the given practical application. Vincotech GmbH hereby disclaims any and all warranties and liabilities of any kind (including without limitation warranties of noninfringement of intellectual property rights of any third party) with respect to any and all information given in this document.

1 Introduction

In this application note the Evaluation Board for the module P95x or in other words the *flowIPM 1B* is described. This board gives a plug and play solution to get familiar with the switching behavior and efficiency of the mentioned module.

The following picture shows the driver board.

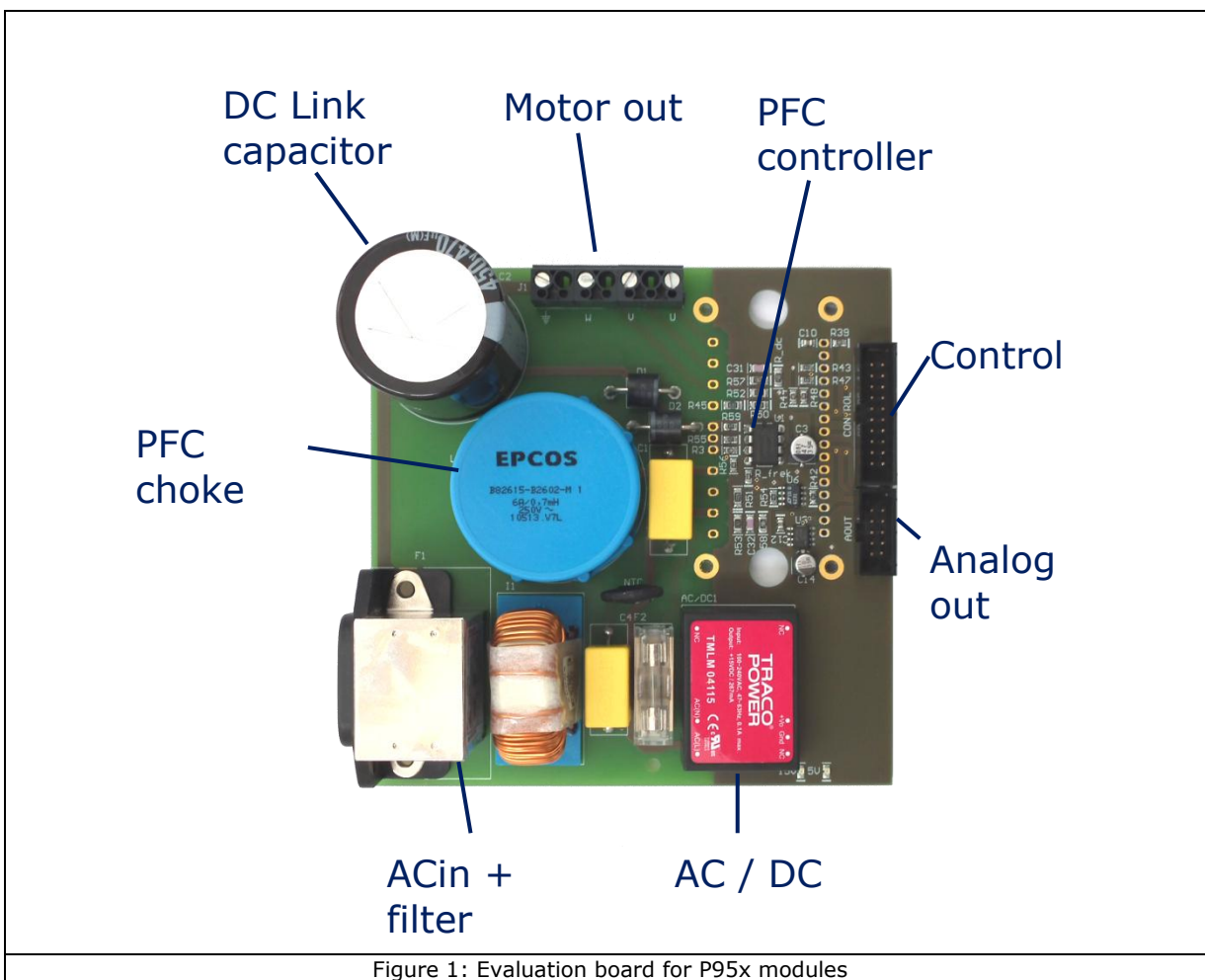

Figure 1: Evaluation board for P95x modules

Ordering numbers:

Ordering number	Description
EVA-P952-A45	Assembled PCB with soldered power module P952-A45
EVA-P953-A45	Assembled PCB with soldered power module P953-A45
EVA-P955-A45	Assembled PCB with soldered power module P955-A45

Table 1: Ordering numbers

2 Features of the board

The next chapter describes the main features, basic electrical parameters as well as pin assignments and mechanical dimensions.

2.1 Main features

- P95x power module featuring rectifier, PFC, six-pack with driver, and current sensing shunts
- Complete 1 kW PFC circuit with PFC controller (switching frequency settable by resistor)
- 110 VAC – 230 VAC single phase input with 2 stage EMC filter, fuse and NTC inrush protection
- 380 VDC link (settable by resistor)
- 3 phase 230 VAC motor output
- V TTL compatible inverting (active low) PWM inputs for the six-pack
- Dedicated Enable input (active high)
- Fault output signal (open collector)
- AC/DC converter for powering the PFC controller
- PCB is designed to fulfill the requirements of IEC61800-5-1, pollution degree 2, overvoltage category III

2.2 Electrical parameters

		min.	typ.	max	Unit	Remarks
AC input voltage		90		250	VAC	47-63 Hz
AC input current				5	Arms	
DC link voltage		230	400	450	VDC	
AC output current				3.5	Arms	
Module_Fault_N output				8	mA	Open collector
Voltage for logic Inputs	U _{InH} ,	1.7	2.1	2.4	V	Inverse TTL
	U _{InL}	0.7	0.9	1.1		
Input current for PWM				200	μA	
Analog output	S_PFC	0	U_REF	3	V	0.22 V/A
	S_INV	0	U_REF	3		0.25 V/A
	DC2+_M		2.26			@400 VDC
	DC1+_M		1.83			@324 Vdcpeak
	NTC2		2.7			@Th = 25 °C
Reference voltage	U_REF		1.6			Shunt current measurement
f _{sw} PFC – switching frequency		106	133	161	kHz	@R4xR_frek= 33 kΩ
T _{hmax} – Power Module				100	°C	
T _{OP} – Operation ambient temperature			-40		85	°C
T _{ST} – Storage temperature			-40		85	°C

Table 2: Electric parameters



2.3 Pin assignments

Connector		Pin name	Direction	Description
Symbol	Pin			
F1	1	L	Power I	1~ power input
	3	N	Power I	Null potential input
	2	Earth	Power I/O	Safety earth
J1	1	U	Power O	3~ output to motor drive
	2	V	Power O	3~ output to motor drive
	3	W	Power O	3~ output to motor drive
	4	Earth	Power I/O	Safety earth
AOUT	1	GND	Power O	Power for measure logic
	2	S_PFC	Analog O	Analog signal from PFC shunt measured
	3	NC	Not connected	
	4	S_INV	Analog O	Analog signal from six pack shunt measured
	5	NC	Not connected	
	6	DC2+_M	Analog O	Analog signal from DC2 link
	7	DC1+_M	Analog O	Analog signal from rectifier output
	8	NTC2	Analog O	Analog signal from NTC
	9	NC	Not connected	
	10	15V	Power I	Power for measure logic
Control	1	15V	Power I	Power for control logic
	2	NC	Not connected	
	3	Module_Enable	TTL I	Module shut down signal
	4-10	NC	Not connected	
	11	Module_Fault_N	O	Open collector fault signal with internal pull up resistor, active low
	12-13	NC	Not connected	
	14	LIN3_N	TTL I	control signal, active low, bottom IGBT
	15	HIN3_N	TTL I	control signal, active low, top IGBT
	16	LIN2_N	TTL I	control signal, active low, bottom IGBT
	17	HIN2_N	TTL I	control signal, active low, top IGBT
	18	LIN1_N	TTL I	control signal, active low, bottom IGBT
	19	HIN1_N	TTL I	control signal, active low, top IGBT
20	GND	Power O	Power for control logic	

Table 3: Pin description of connectors



2.4 Mechanical dimensions

Mechanical dimensions for width and length: **124 mm x 123 mm**

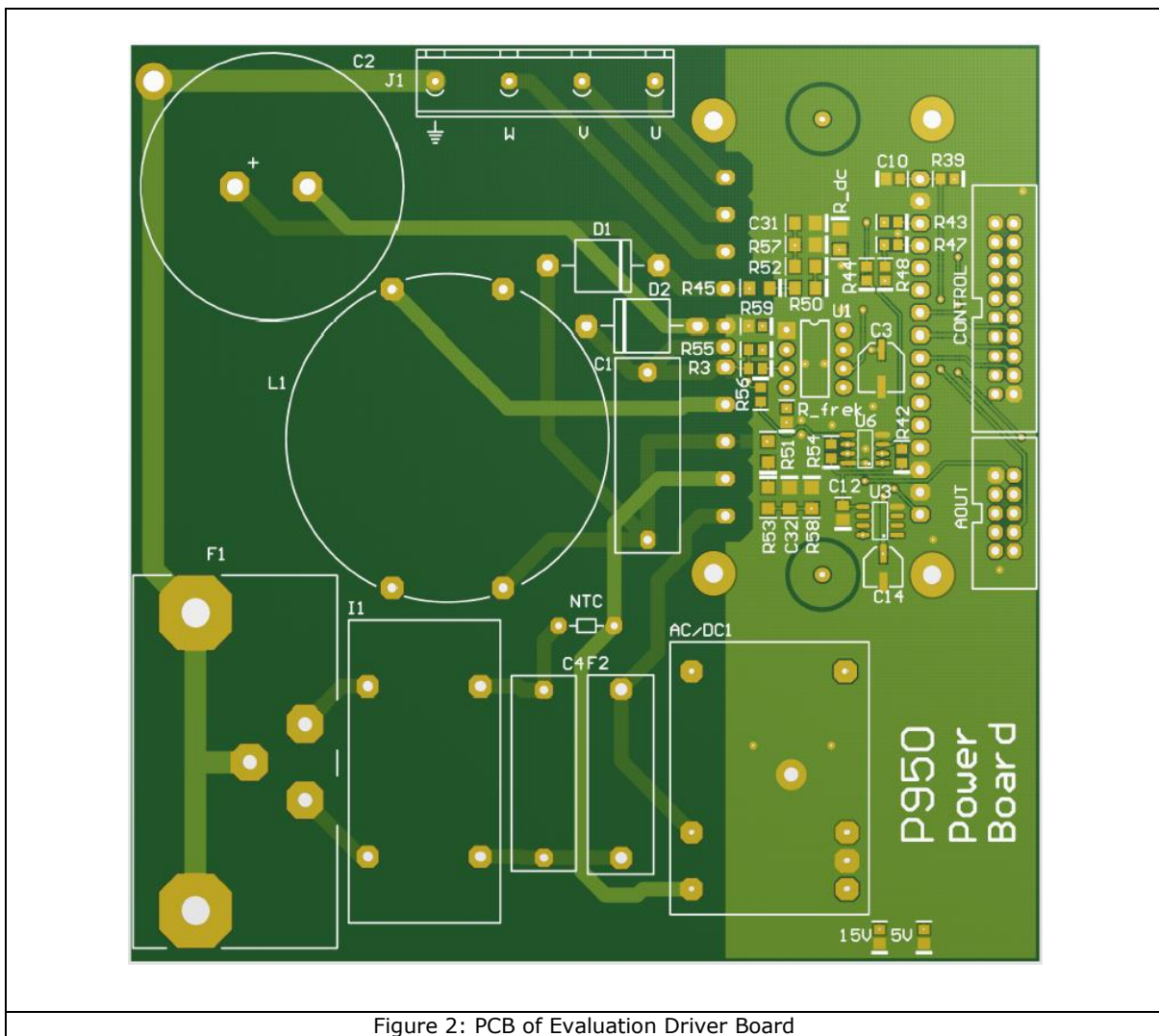

Figure 2: PCB of Evaluation Driver Board

3 Description of electrical parts

This chapter describes the different electrical parts like the input signals, output signals and driver circuit for better understanding how the board works.

In this module a 1~ rectifier is used to convert the voltage from AC to DC. The PFC MOSFET with gate driver makes a Power Factor Correction, so the U_{DC1+} voltage and the rectified current have got same phase shift. Six IGBTs with free-wheeling diodes are implemented for the conversion from DC to AC with variable frequency. There is no braking chopper on the board; therefore the modules cannot be used for braking operation.

The power requirement of P95x kit is a very basic, 1~ AC 110 V – 230 V. For the internal power supply for drivers and measure circuit a compact AC/DC converter is implemented. Please refer to the P95x-A45 datasheet for more information about the power module:

<http://www.vincotech.com/products/by-topologies.html> > IPM

For measurement of the heatsink temperature an NTC is equipped.

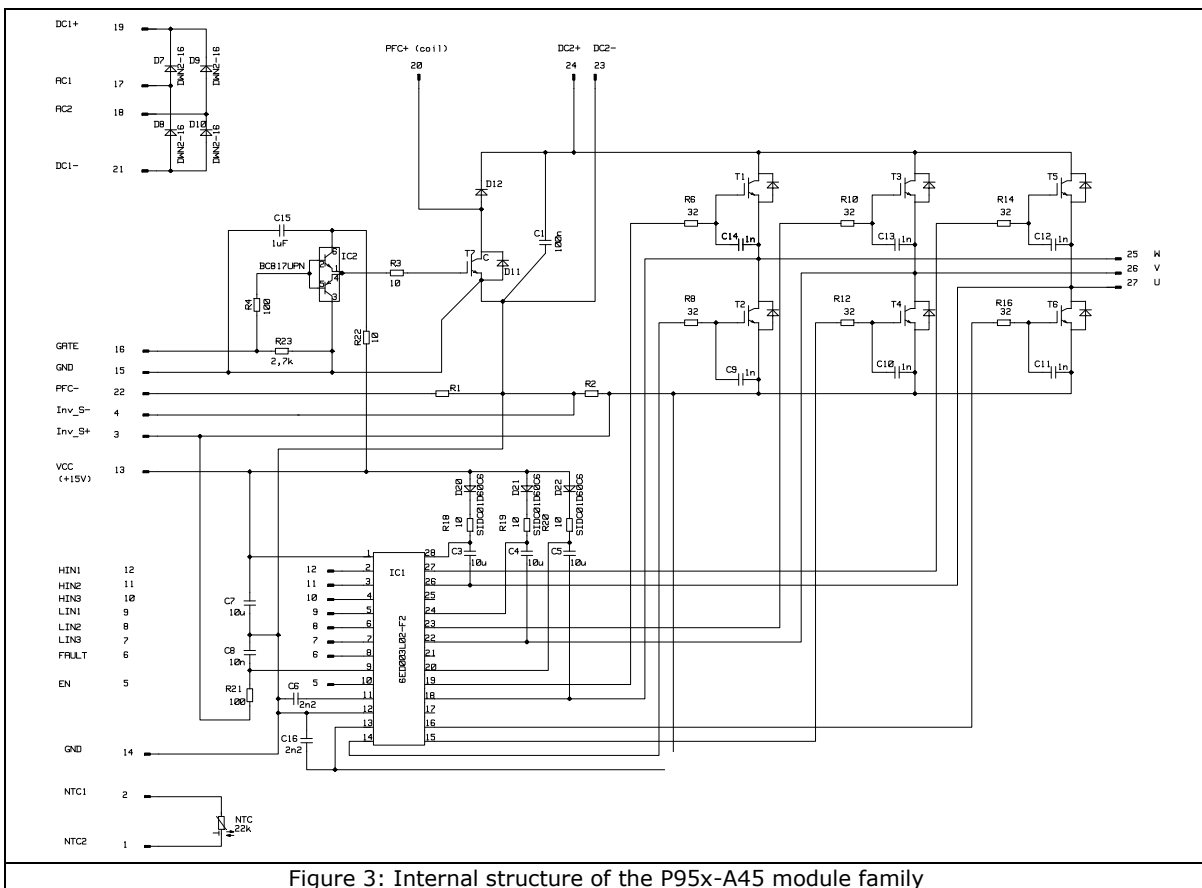

3.1 Input filter and rectification

The input AC voltage rectification is implemented by bridge. The single phase AC input is connected to *F2* which includes one stage EMC filter and the second stage (*I1*, *C4*) is added on board. An NTC is limiting the inrush current at start up. The fuse protects the whole circuit.

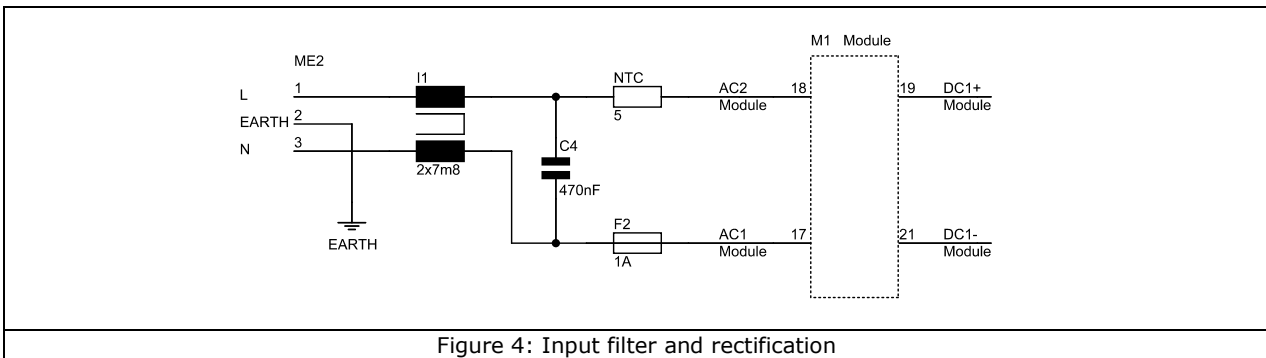

Figure 4: Input filter and rectification

The rectified voltage on pin 19 and pin 21 of the module is named DC1 link. These powers up to the PFC circuit which is described in the next chapter.

3.2 PFC

1 kW PFC circuit is included in the board with settable switching frequency and settable DC2 link voltage and with *C2* capacitor (560 μ F/450 VAC). The PFC IGBT, PFC diode, gate driver and shunt resistor have been integrated in the module. The value of the PFC inductor *L1* is 0.7 mH. *D1* and *D2* are protection diodes for the PFC shunt and PFC diode.

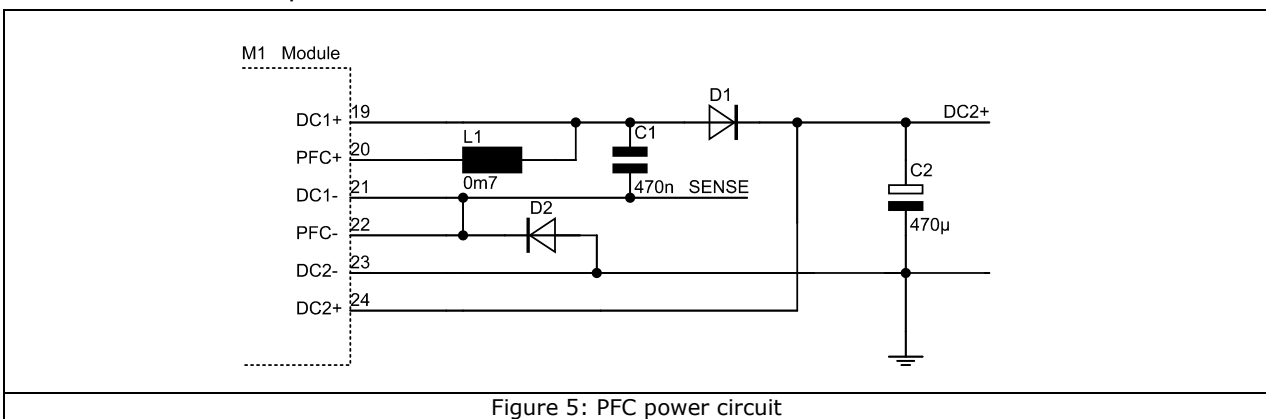

Figure 5: PFC power circuit

The switching signals for the integrated MOSFET are generated by the ICE2PCS01 PFC controller. This is powered with an AC/DC converter supplying +15 V. Two resistors connected to pin 4 of the PFC controller adjust the switching frequency. This is set by *R4* and *R_freq* to 130 kHz. Changing *R_freq* change the switching frequency.

$$R_{freq_set} = \frac{R4 \cdot R_freq}{R4 + R_freq}$$

The datasheet of the ICE2PCS01 shows a diagram with the dependency of R_{freq_set} and the switching frequency.

The voltage of $DC2+$ can be modified with the resistor R_{dc} .

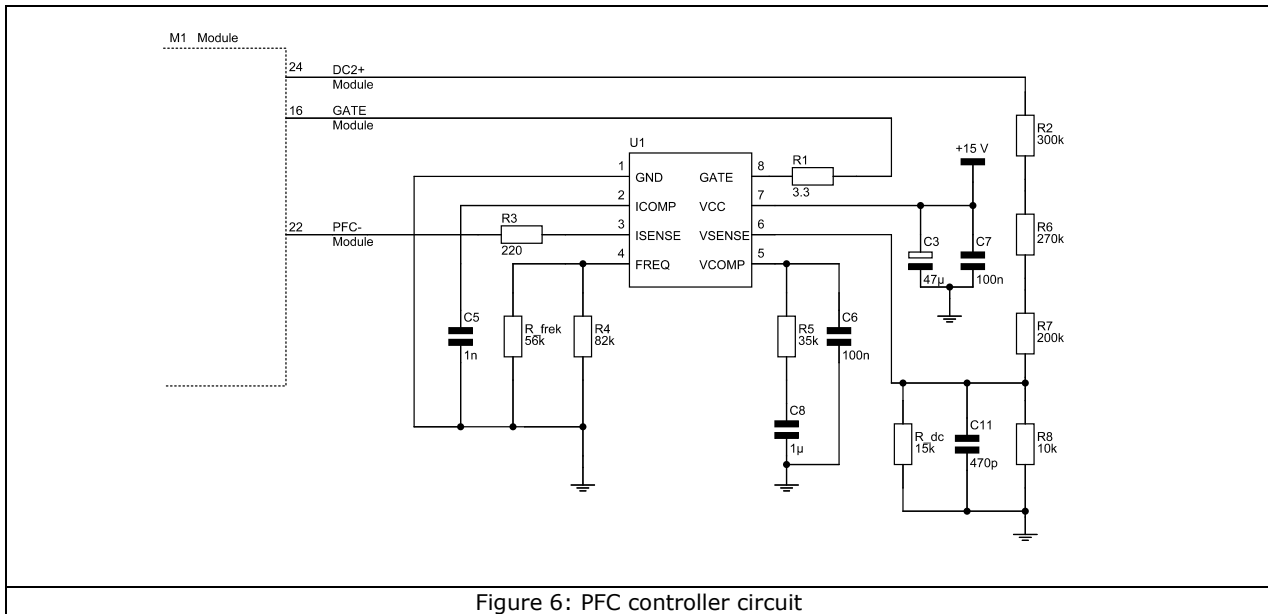

Figure 6: PFC controller circuit

The default voltage is approx. 400 VDC. This is the maximum suggested DC-Link voltage. The following equation shows how to adjust the voltage of the DC-Bus. The internal reference voltage of the PFC controller is 3 V.

$$U_{DC2+} = \frac{3V \cdot \left(\frac{R8 \cdot R_{dc}}{R8 + R_{dc}} + R2 + R6 + R7 \right)}{\frac{R8 \cdot R_{dc}}{R8 + R_{dc}}}$$

There has been a PFC shunt resistor integrated in the module. By this shunt the PFC current can be measured. The kit contains dual differential amplifier. One amplifier is used to measure the current through the PFC shunt and the other amplifier is used to measure the DC-Link current which will be explained more in detail in the next chapter.

The power module P95x has a build in low side gate driver for the PFC switch. This allows low output currents of the PFC controller and guarantees also a fast and save switching of the PFC switch itself. The low side gate driver circuit is based on the BC817UPN which has an output current of 1 A. Refer to the datasheet for more information.

http://www.infineon.com/dgdl/Infineon-BC817UPN-DS-v01_01-en.pdf

Pin 2 of AOUT connector has U_REF potential when no current is driven through the PFC shunt. If the PFC stage works the S_PFC output signal change according to the current through the shunt. Refer to the following figure.

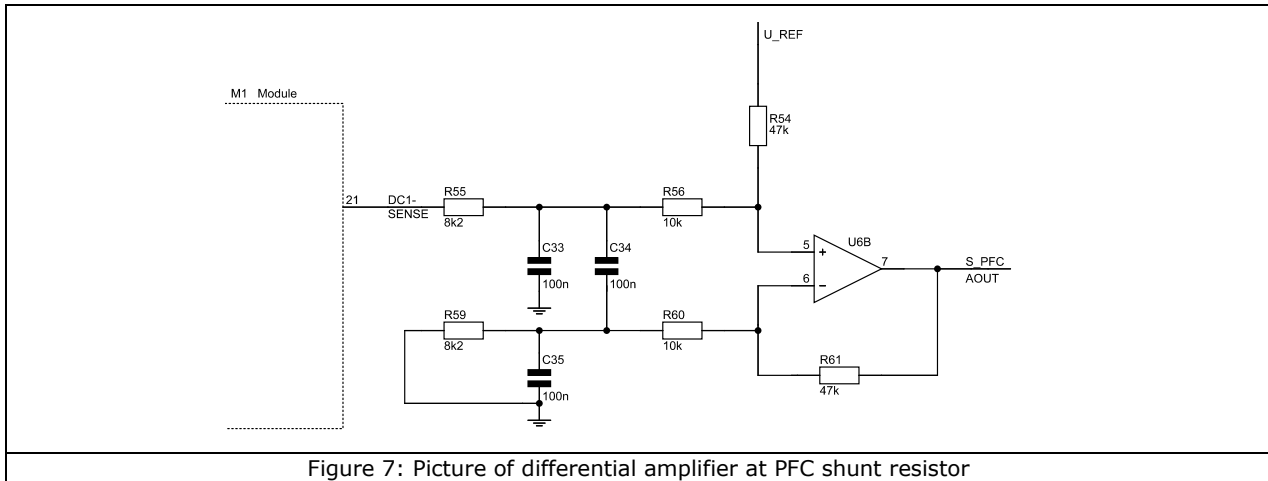

Figure 7: Picture of differential amplifier at PFC shunt resistor

Check the datasheet of the PFC controller ICE2PCS01 for more information.

3.3 Inverter part and shunt measurement

The inverter switches, contained in the module gets the drive signals from the TTL level PWM input signals. Level shifters and high side bootstrap driver are also included in the module. For the measurement of the motor current there is a DC link shunt in the common emitter of low side IGBTs (eg. shunt with a value of 25 mΩ is implemented in the 10 A P955 modules). InvS+ and InvS- are connected direct to the inverter shunt and provide a signal through the second differential amplifier to the AOUT connector.

Like for the PFC shunt measurement the output signal is shifted with the U_REF voltage. If the motor is not in operation U_REF is forwarded to pin 4. If the motor is driven, the potential of pin 4 will change according to the current flow through the shunt.

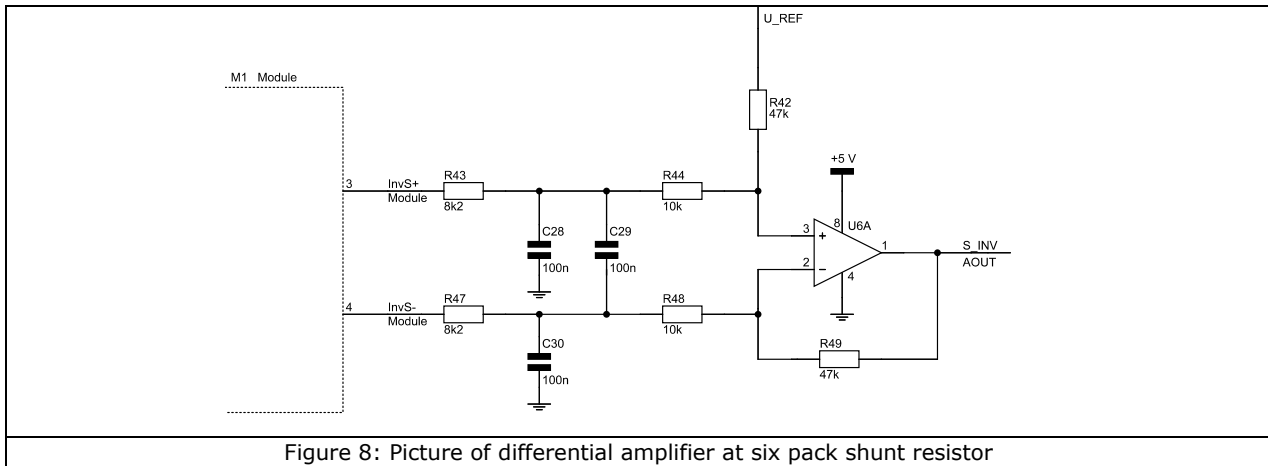

Figure 8: Picture of differential amplifier at six pack shunt resistor

3.4 Voltage measurements

The kit contains two voltage dividers. Through those the voltage after the rectification U_{DC1+} and the voltage after the PFC stage U_{DC2+} can be measured. The output of voltage dividers is 1.83 V_{peak} / 324 V_{peak} for the U_{DC1+_M} and 2.20 V / 400 V DC in case of U_{DC2+_M} . The voltages are provided to the connector AOUT. The following equations show how to calculate:

$$U_{DC1+_M} = U_{DC1+} \cdot \frac{R58}{R46 + R51 + R53 + R58}$$

$$U_{DC2+_M} = U_{DC2+} \cdot \frac{R57}{R45 + R50 + R52 + R57}$$

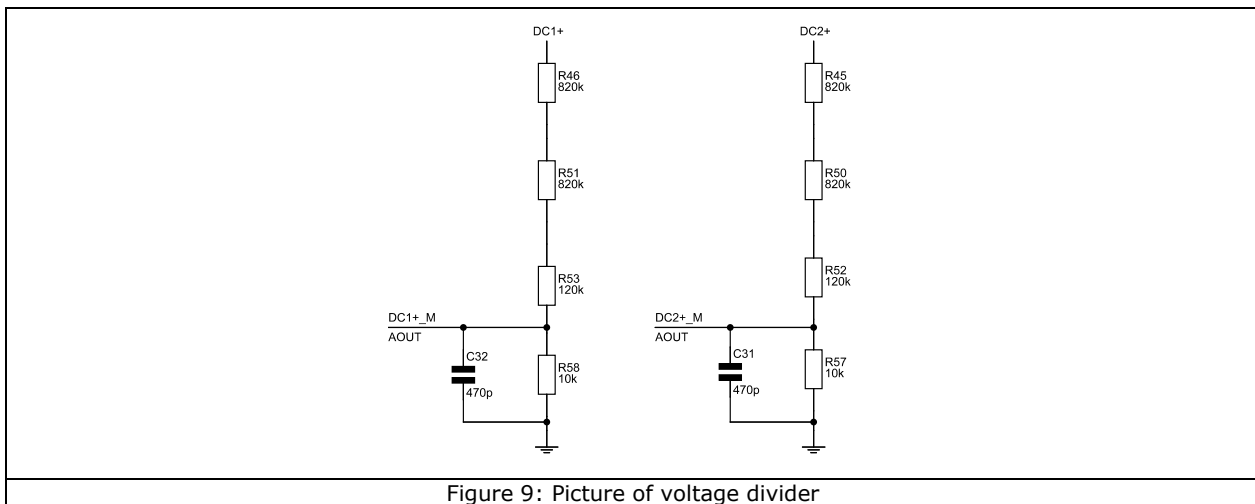
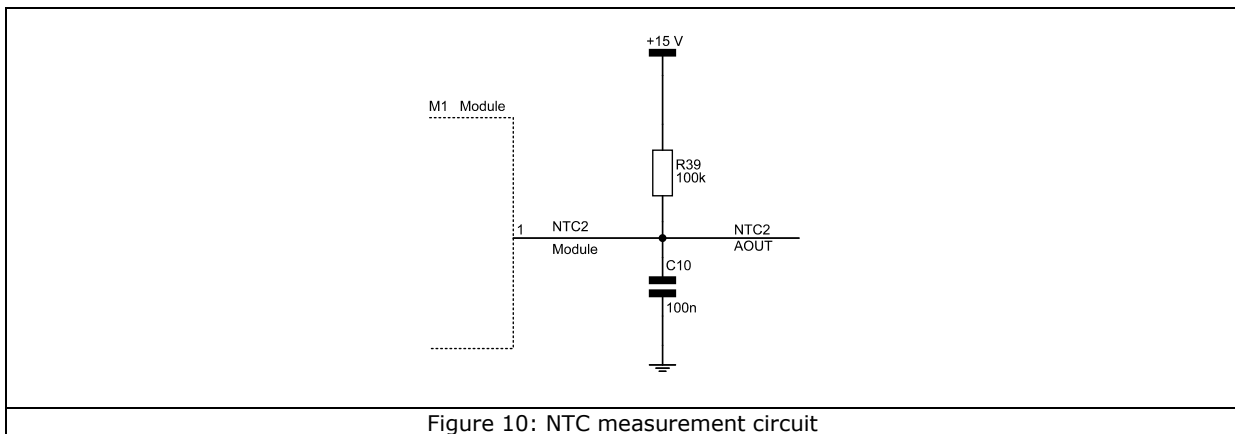

Figure 9: Picture of voltage divider

It is recommended only to change $R58$ or $R57$.

3.5 Temperature measurement

The internal NTC for temperature measurement can be monitored via the AOUT connector. For calculating heatsink temperature the following circuit can be used, and the NTC characteristics can be read from the module datasheet:



The thermistor has a resistance of 22 kΩ at 25 °C and a $B_{(25/50)}$ -value of 3950 K. The relation between resistance and temperature of the NTC is expressed as:

$$R_{NTC} = R_{25} \cdot \left[B_{25/50} \left(\frac{1}{T_2} - \frac{1}{298,15K} \right) \right]$$

Where T_2 is the measured NTC temperature.

4 Operation

The module can be activated via an active high signal on the pin 3 of the control connector. By default the module is disabled.

Before the module can handle the PWM signals from the microcontroller if is necessary to wait at least 800 ns after the enable signal is applied.

The following startup sequence should be applied:

- MODUL_ENABLE signal go LOW
- wait for at least 800 ns
- start the PWM
- MODULE_ENABLE signal go HIGH

Fault signal is generated in case of short circuit on the output. In this case set the MODULE_ENABLE signal to disable within 5 μ s time, and it must be kept in this state for at least one second. The number of allowed short circuits is limited to 1000. The recommended switching frequency is 16 kHz.

Check the sixpack driver IC under this link:

http://www.infineon.com/dgdl/Infineon-6ED003L0x_F2-DS-v02_07-EN.pdf

5 Definition of layers

The driver board is based on a 2-Layer PCB. The used material is FR4. Figure 11 depicts a cross section of the layer thickness and for pre-packs.

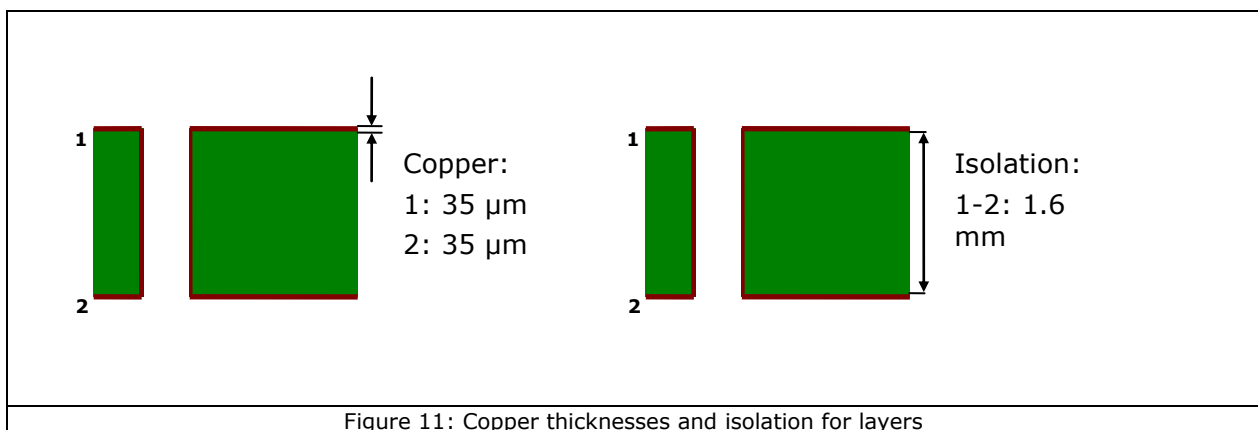



6 Layout

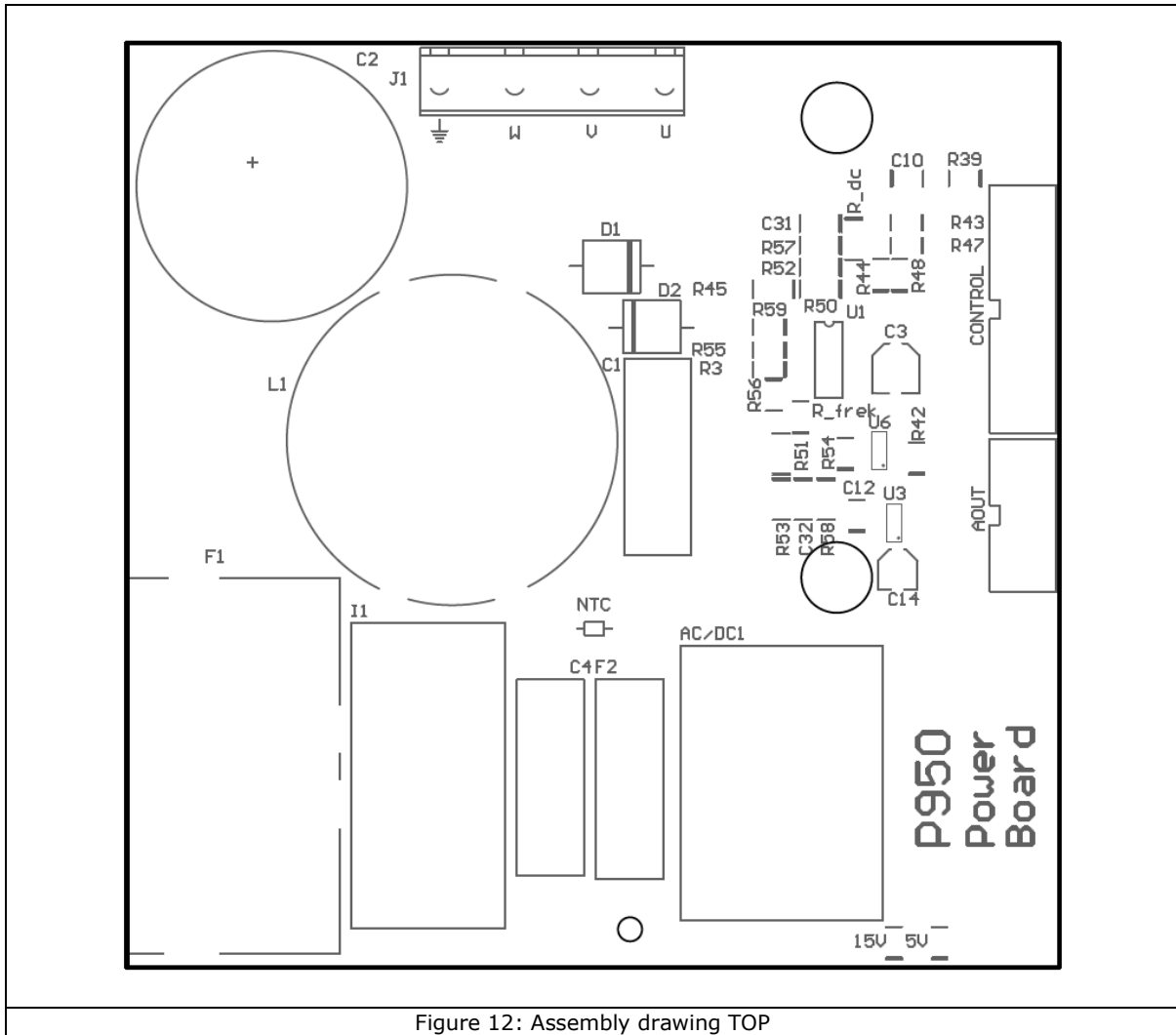

Figure 12: Assembly drawing TOP

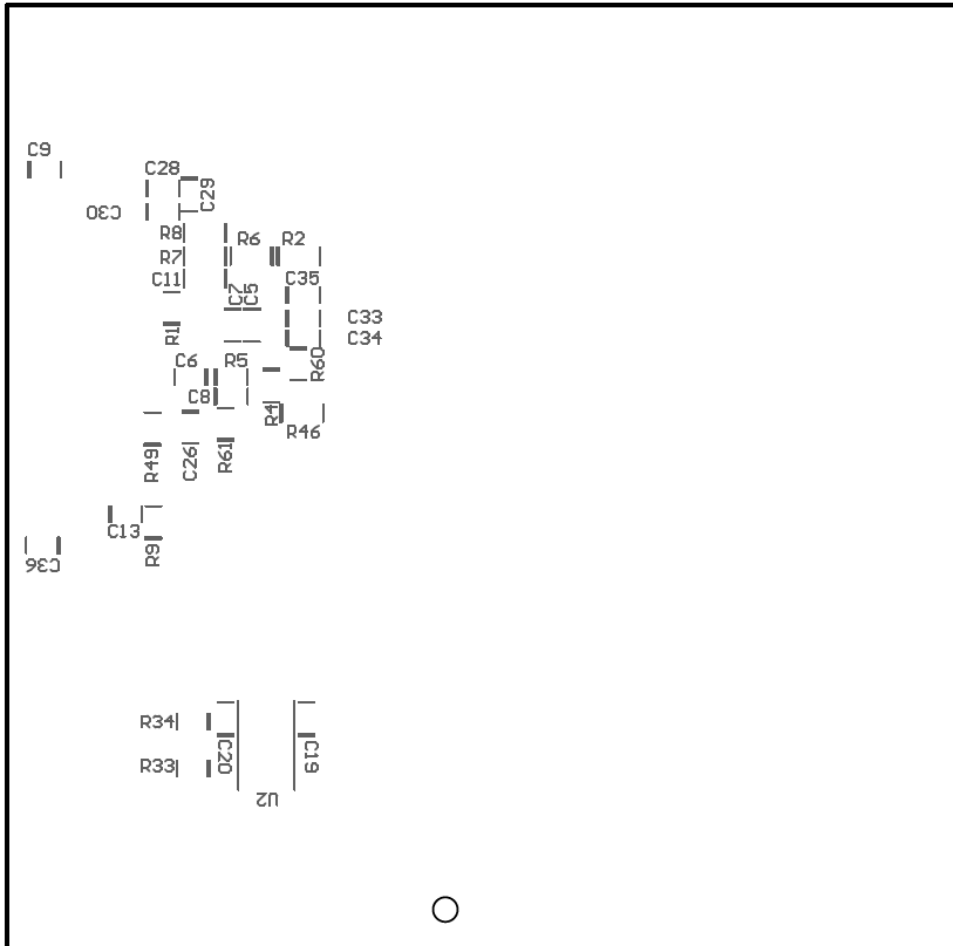

Figure 13: Assembly drawing BOTTOM

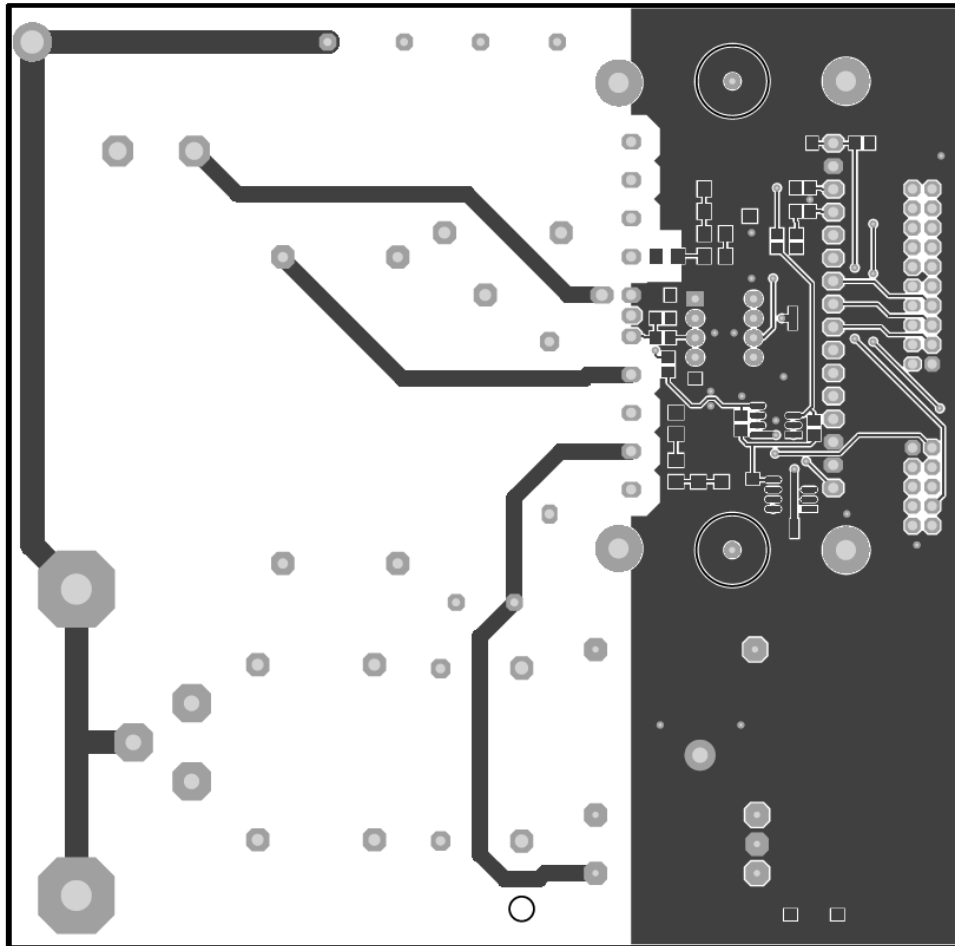

Figure 14: TOP layer

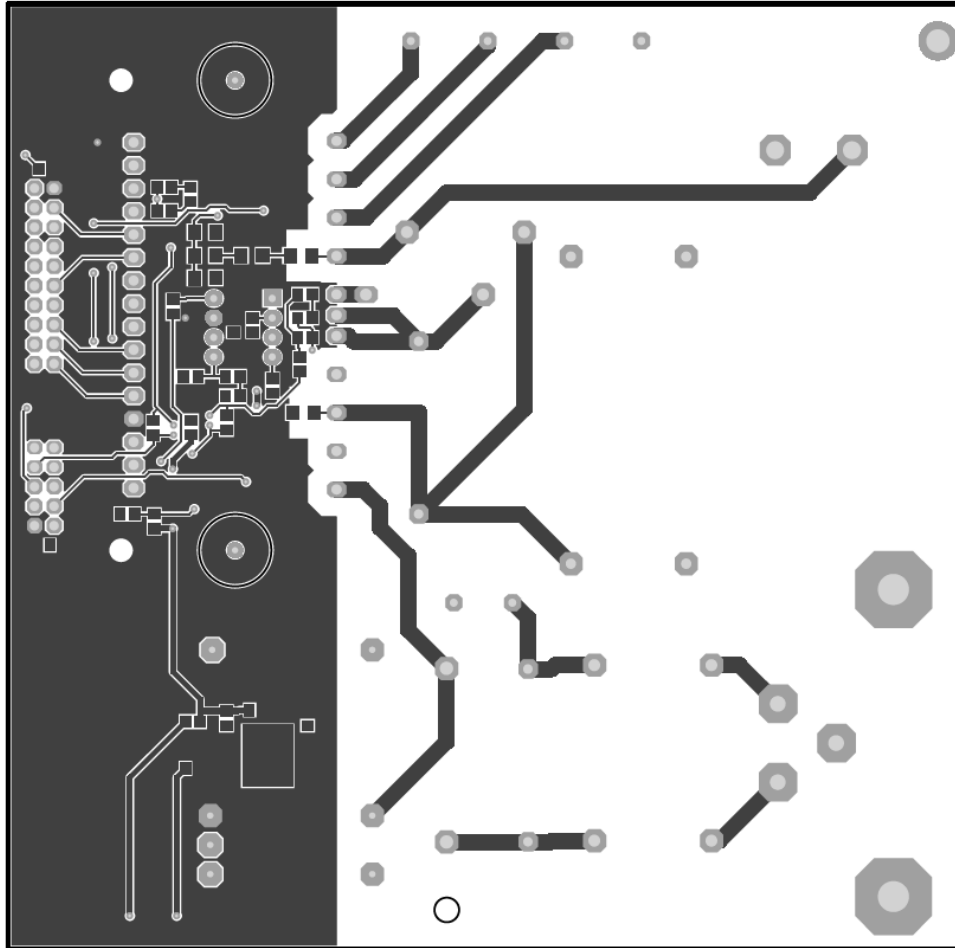
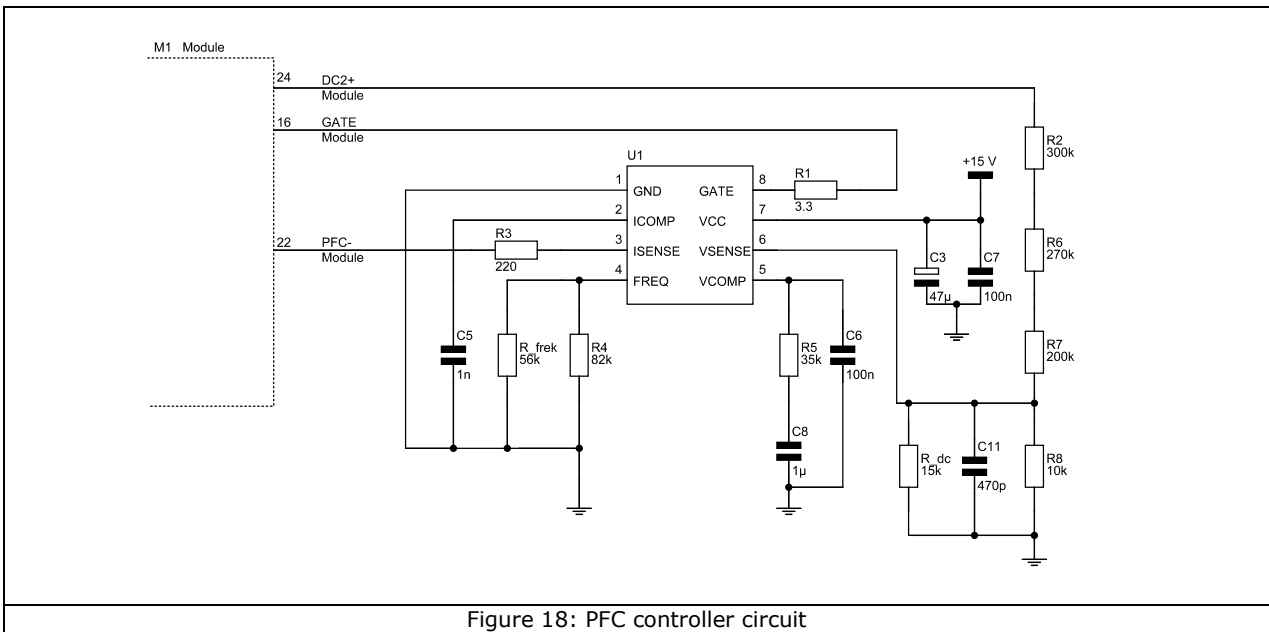
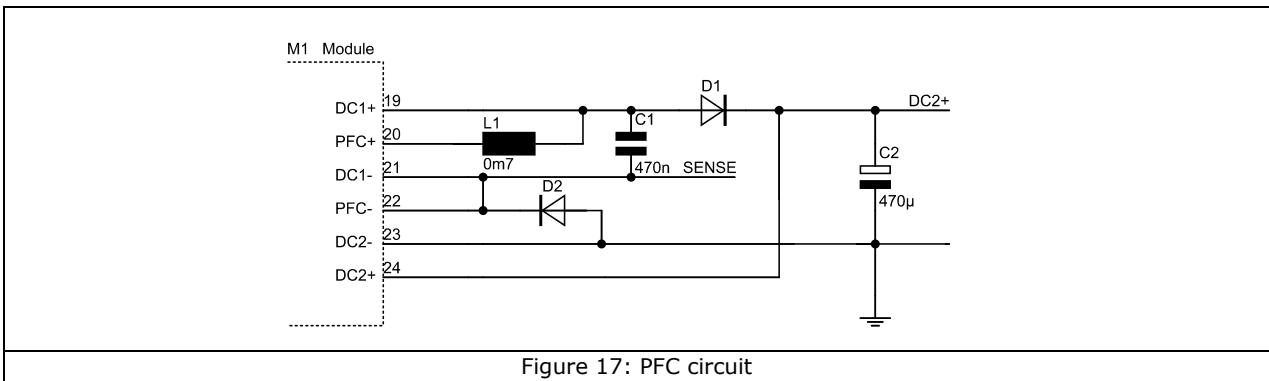
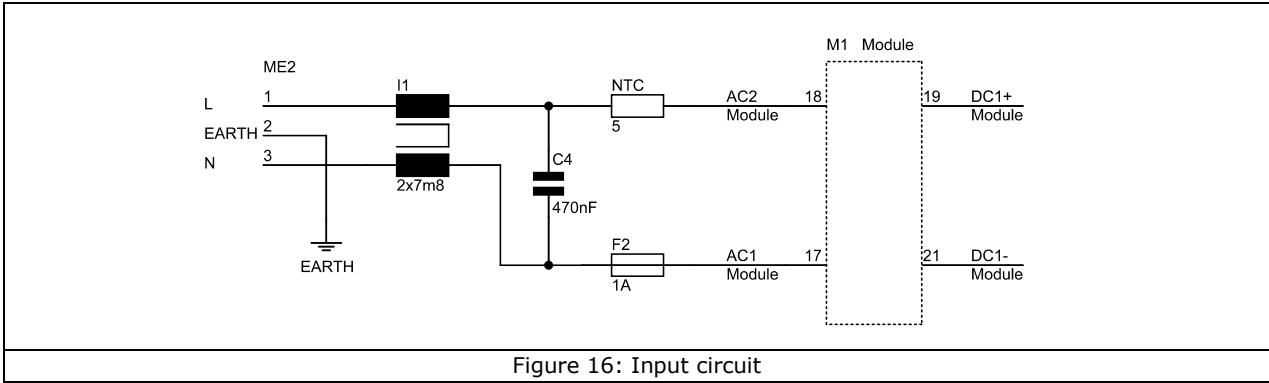
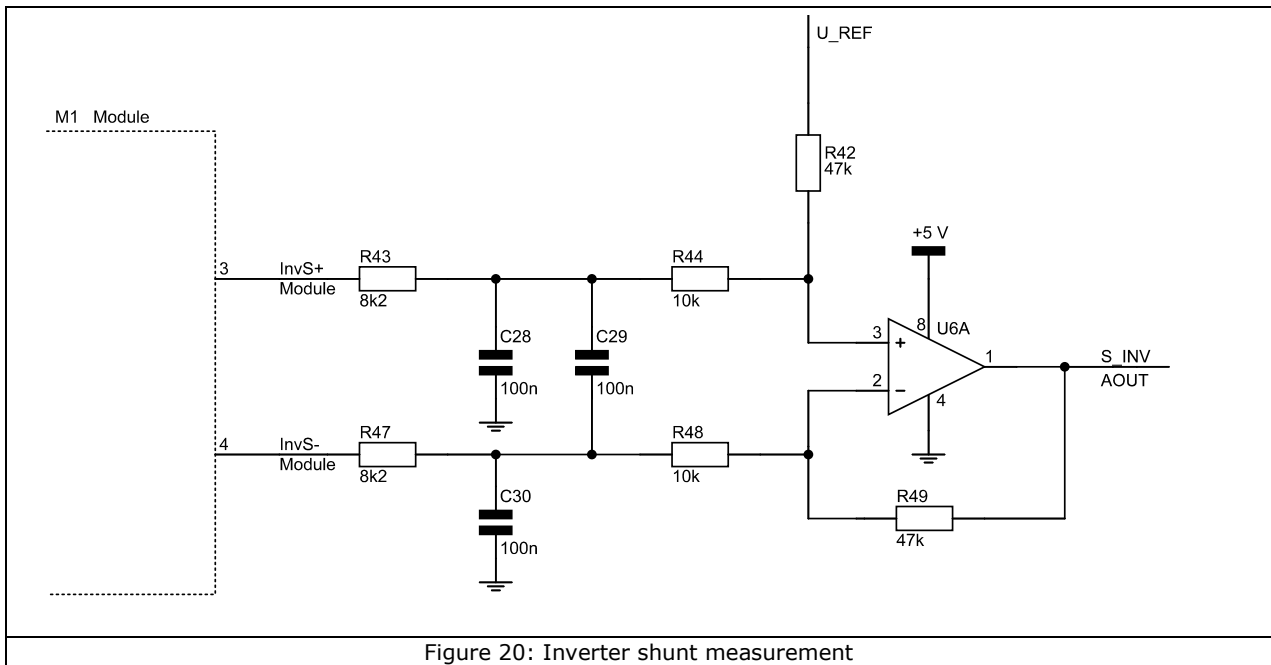
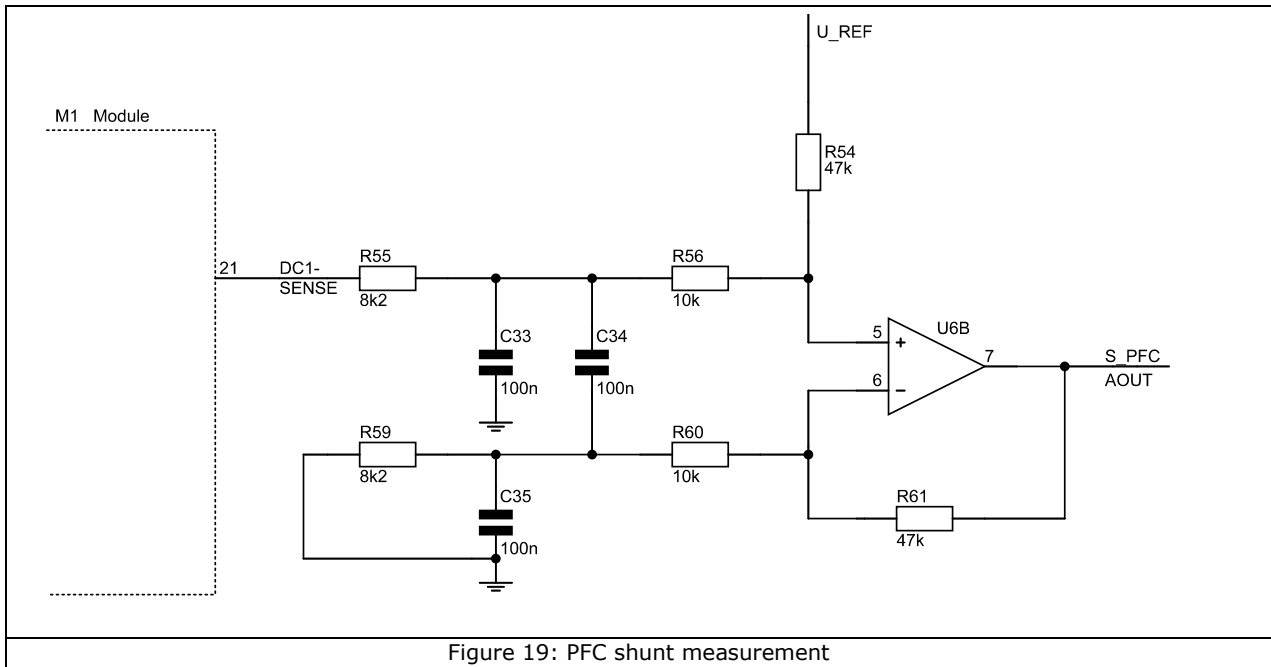

Figure 15: BOTTOM layer



7 Schematics





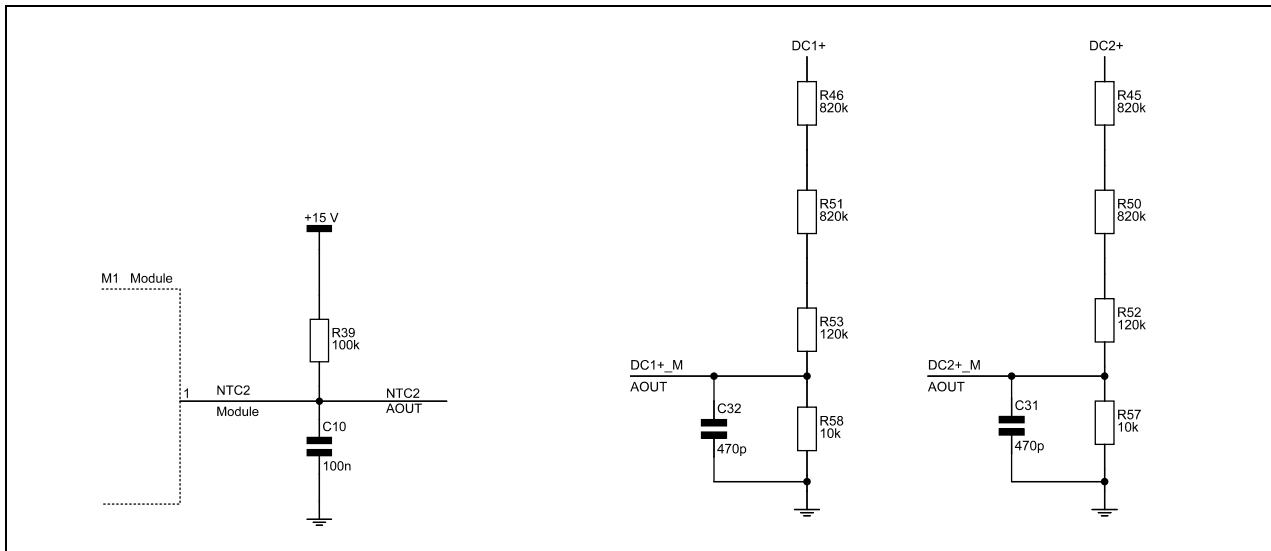

Figure 21: Temperature and voltage measurement

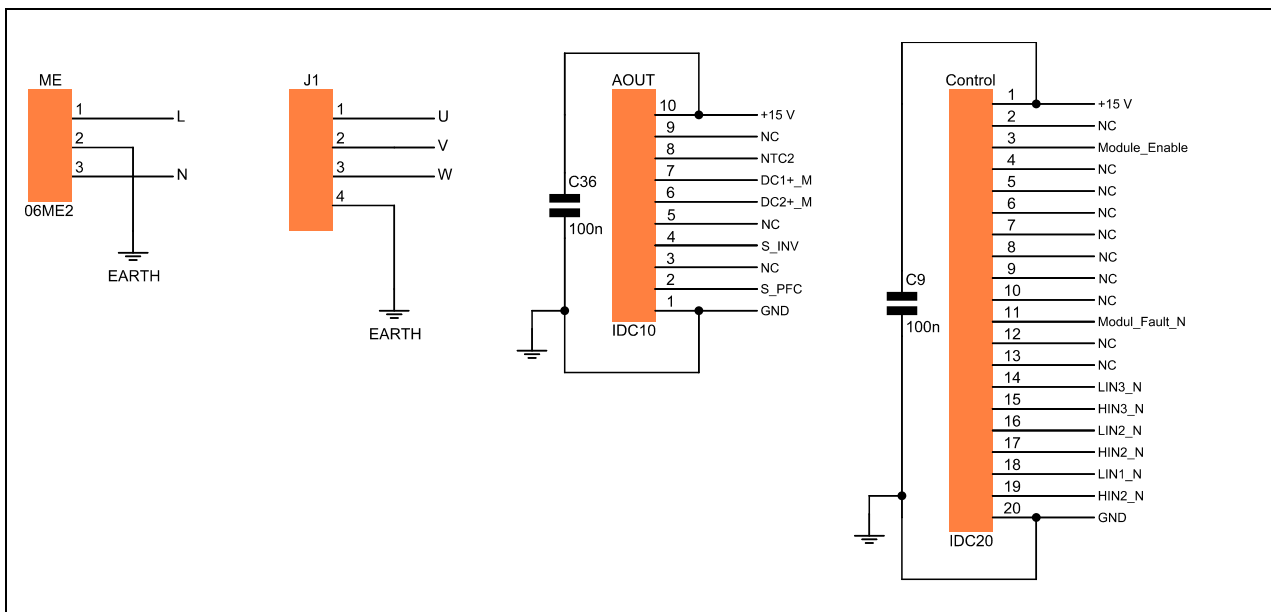

Figure 22: Connectors

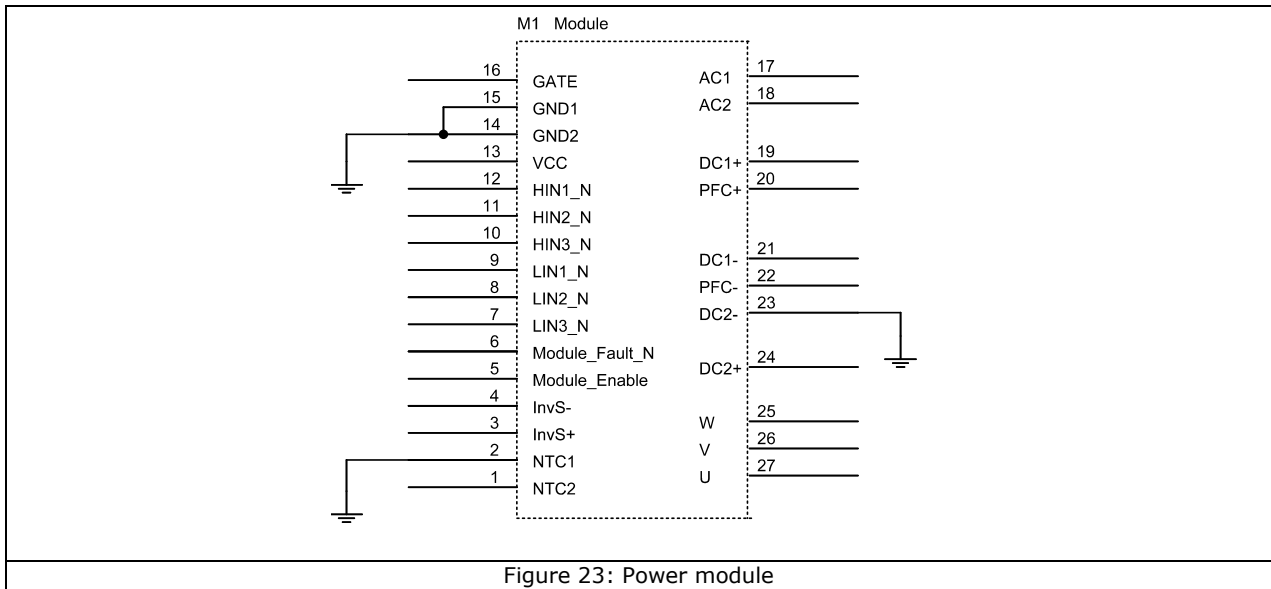

Figure 23: Power module

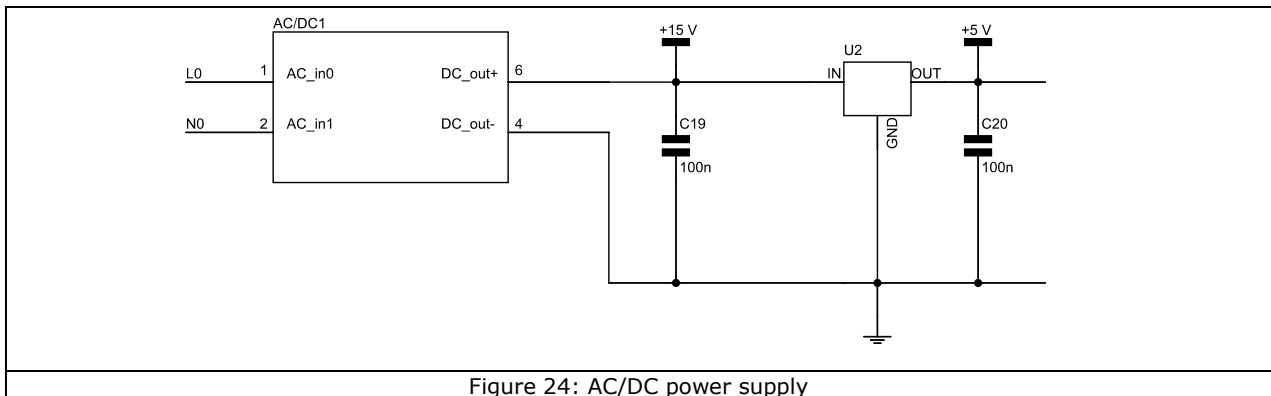

Figure 24: AC/DC power supply

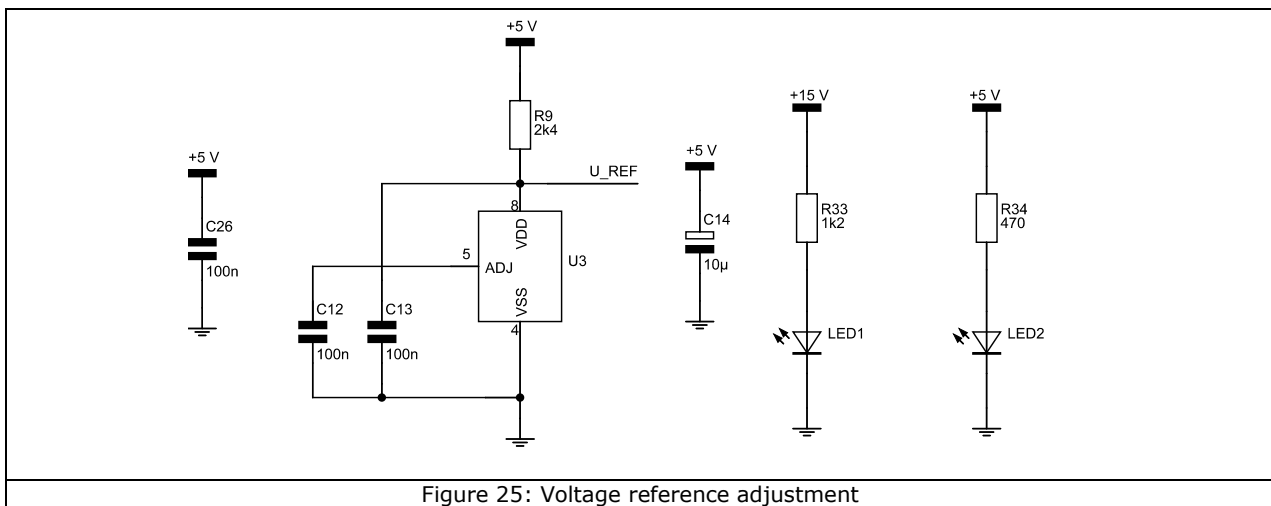

Figure 25: Voltage reference adjustment



8 BOM

Comment	Designator	Footprint	Quantity	Value
LED1	5V	0805	1	
LED2	15V	0805	1	
2X5 CONNECTOR	AOUT	IDC10	1	
HEADER2X10	CONTROL	IDC20	1	
HEADER1X4	J1	Power_Header_4X10mm	1	
LM336	CONTROL, J1, U3	SOP8	1	
AC/DC_converter	AC/DC1	TRACO_TMLM_04	1	AC230/DC15
CAPACITOR	C1, C4	RAD0.9	2	470nF/250V AC
CAPACITOR	C11, C31, C32	1206	3	470pF
CAPACITOR	C14	5X5.5	1	10uF/16V
CAPACITOR	C2	C10.35	1	470uF/450v
CAPACITOR	C3	6.3X6.3	1	47uF/35V
CAPACITOR	C5	0805	1	1nF
CAPACITOR	C6, C7, C9, C10, C12, C13, C19, C20, C26, C28, C29, C30, C33, C34, C35, C36	0805	16	100nF
CAPACITOR	C8	0805	1	1uF
DIODE	D1, D2	DIODE0.6	2	P600M
FILTER	F1	FILTER1	1	ME2
FUSE	F2	FUSE	1	1A
COMMON CORE INDUCTOR	I1	EPCOS_IND0684-A-E	1	2X7.8mH
INDUCTOR	L1	EPCOS_IND0232-V	1	0.7mH
RESISTOR	NTC	AXIAL0.3	1	5 ohm
RESISTOR	R_dc	1206	1	15K
RESISTOR	R_freK	0805	1	56K
RESISTOR	R1	0805	1	3.3
RESISTOR	R2	1206	1	300K
RESISTOR	R3	0805	1	220
RESISTOR	R33	0805	1	1.2K
RESISTOR	R34	0805	1	470
RESISTOR	R39	0805	1	100K
RESISTOR	R4	0805	1	82K
RESISTOR	R42, R49, R54, R61	0805	4	47K
RESISTOR	R43, R47, R55, R59	0805	4	8.2K
RESISTOR	R45, R46, R50, R51	1206	4	820K
RESISTOR	R5	0805	1	33K
RESISTOR	R52, R53	1206	2	120K
RESISTOR	R6	1206	1	270K



Comment	Designator	Footprint	Quantity	Value
RESISTOR	R7	1206	1	200K
RESISTOR	R8, R44, R48, R56, R57, R58, R60	1206, 0805, 0805, 0805, 1206, 1206, 0805	7	10K
RESISTOR	R9	0805	1	2.4K
ICE1PCS01	U1	DIP8	1	ICE2PCS01
VOLTREG	U2	DPACK	1	78M05
OPAMP	U6	SOP8	1	LT 6231CS8

Table 4: Bill of material