



MiniSKiiP PIM 2

1200 V / 35 A

Topology features

- Converter+Brake+Inverter
- Kelvin Emitter for improved switching performance
- Temperature sensor

Component features

- Easy paralleling
- Low turn-off losses
- Low collector emitter saturation voltage
- Positive temperature coefficient
- Short tail current
- Switching optimized for EMC

Housing features

- Base isolation: Al₂O₃
- Easy assembly in one mounting step
- Flexible PCB design w/o pin holes
- Rugged solderless spring contacts

Extra features

- Equivalent: SKiiP 24NAB12T4V1

Target applications

- Industrial Drives

Types

- 80-M212PMA035M7-K220A70

MiniSKiiP® 2 16 mm housing

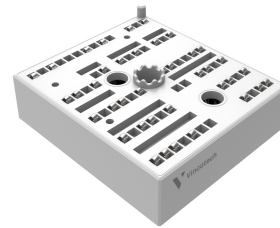

Schematic

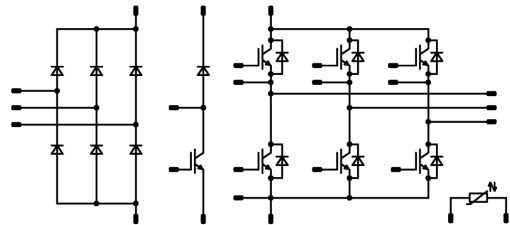



Vincotech

80-M212PMA035M7-K220A70
datasheet

Maximum Ratings

$T_j = 25\text{ °C}$, unless otherwise specified

Parameter	Symbol	Conditions	Value	Unit
Inverter Switch				
Collector-emitter voltage	V_{CES}		1200	V
Collector current (DC current)	I_C	$T_j = T_{jmax}$ $T_s = 80\text{ °C}$	57	A
Repetitive peak collector current	I_{CRM}	t_p limited by T_{jmax}	70	A
Total power dissipation	P_{tot}	$T_j = T_{jmax}$ $T_s = 80\text{ °C}$	129	W
Gate-emitter voltage	V_{GES}		± 20	V
Short circuit ratings	t_{SC}	$V_{GE} = 15\text{ V}$, $V_{CC} = 800\text{ V}$ $T_j = 150\text{ °C}$	9,5	μs
Maximum junction temperature	T_{jmax}		175	$^{\circ}\text{C}$

Inverter Diode				
Peak repetitive reverse voltage	V_{RRM}		1200	V
Forward current (DC current)	I_F	$T_j = T_{jmax}$ $T_s = 80\text{ °C}$	45	A
Repetitive peak forward current	I_{FRM}	t_p limited by T_{jmax}	70	A
Total power dissipation	P_{tot}	$T_j = T_{jmax}$ $T_s = 80\text{ °C}$	89	W
Maximum junction temperature	T_{jmax}		175	$^{\circ}\text{C}$

Brake Switch				
Collector-emitter voltage	V_{CES}		1200	V
Collector current (DC current)	I_C	$T_j = T_{jmax}$ $T_s = 80\text{ °C}$	57	A
Repetitive peak collector current	I_{CRM}	t_p limited by T_{jmax}	70	A
Total power dissipation	P_{tot}	$T_j = T_{jmax}$ $T_s = 80\text{ °C}$	129	W
Gate-emitter voltage	V_{GES}		± 20	V
Short circuit ratings	t_{SC}	$V_{GE} = 15\text{ V}$, $V_{CC} = 800\text{ V}$ $T_j = 150\text{ °C}$	9,5	μs
Maximum junction temperature	T_{jmax}		175	$^{\circ}\text{C}$

**Maximum Ratings** $T_j = 25\text{ °C}$, unless otherwise specified

Parameter	Symbol	Conditions	Value	Unit
Brake Diode				
Peak repetitive reverse voltage	V_{RRM}		1200	V
Forward current (DC current)	I_F	$T_j = T_{jmax}$ $T_s = 80\text{ °C}$	45	A
Repetitive peak forward current	I_{FRM}	t_p limited by T_{jmax}	70	A
Total power dissipation	P_{tot}	$T_j = T_{jmax}$ $T_s = 80\text{ °C}$	89	W
Maximum junction temperature	T_{jmax}		175	°C

Rectifier Diode

Peak repetitive reverse voltage	V_{RRM}		1600	V
Forward current (DC current)	I_F	$T_j = T_{jmax}$ $T_s = 80\text{ °C}$	50	A
Surge (non-repetitive) forward current	I_{FSM}	Single Half Sine Wave, $t_p = 10\text{ ms}$ $T_j = 150\text{ °C}$	270	A
Surge current capability	I^2t		370	A ² s
Total power dissipation	P_{tot}	$T_j = T_{jmax}$ $T_s = 80\text{ °C}$	64	W
Maximum junction temperature	T_{jmax}		150	°C

Module Properties**Thermal Properties**

Storage temperature	T_{stg}		-40...+125	°C
Operation temperature under switching condition	T_{jop}		-40...+($T_{jmax} - 25$)	°C

Isolation Properties

Isolation voltage	V_{isol}	DC Test Voltage* $t_p = 2\text{ s}$	5500	V
Isolation voltage	V_{isol}	AC Voltage $t_p = 1\text{ min}$	2500	V
Creepage distance		With std lid For more informations see handling instructions	6,3	mm
Clearance		With std lid For more informations see handling instructions	6,3	mm
Comparative Tracking Index	CTI		≥ 600	

*100 % tested in production



Characteristic Values

Parameter	Symbol	Conditions					Values			Unit
		V_{GS} [V]	V_{GE} [V]	V_{DS} [V]	V_F [V]	I_C [A] I_D [A] I_F [A]	T_j [°C]	Min	Typ	

Inverter Switch

Static

Gate-emitter threshold voltage	$V_{GE(th)}$			10	0,0035	25	5,4	6	6,6	V
Collector-emitter saturation voltage	$V_{CE(sat)}$		15		35	25 125 150		1,47 1,64 1,68	1,85 ⁽¹⁾	V
Collector-emitter cut-off current	I_{CES}		0	1200		25			80	μA
Gate-emitter leakage current	I_{GES}		20	0		25			200	nA
Internal gate resistance	r_g							None		Ω
Input capacitance	C_{ies}							7900		pF
Output capacitance	C_{oes}		0	10		25		270		pF
Reverse transfer capacitance	C_{res}							97		pF
Gate charge	Q_g	$V_{CC} = 600$ V	0/15		35	25		260		nC

Thermal

Thermal resistance junction to sink ⁽²⁾	$R_{th(j-s)}$	$\lambda_{paste} = 2,5$ W/mK (HPTP)						0,73		K/W
--	---------------	--	--	--	--	--	--	------	--	-----

Dynamic

Turn-on delay time	$t_{d(on)}$					25 125 150		124,2 122,4 121,4		ns
Rise time	t_r					25 125 150		14,2 17 17,8		ns
Turn-off delay time	$t_{d(off)}$					25 125 150		178,6 202,8 208,2		ns
Fall time	t_f					25 125 150		95,14 117,86 118,79		ns
Turn-on energy (per pulse)	E_{on}	$Q_{tfWD}=4,34$ μC $Q_{tfWD}=6,18$ μC $Q_{tfWD}=6,9$ μC				25 125 150		1,45 1,92 2,09		mWs
Turn-off energy (per pulse)	E_{off}					25 125 150		2,4 3,17 3,42		mWs



Vincotech

80-M212PMA035M7-K220A70
datasheet

Characteristic Values

Parameter	Symbol	Conditions					Values			Unit
		V_{GE} [V] V_{GS} [V]	V_{CE} [V] V_{DS} [V] V_F [V]	I_C [A] I_D [A] I_F [A]	T_j [°C]	Min	Typ	Max		
Inverter Diode										
Static										
Forward voltage	V_F				35	25 125 150		1,66 1,76 1,75	2,1 ⁽¹⁾	V
Reverse leakage current	I_R	$V_r = 1200$ V				25			40	μA
Thermal										
Thermal resistance junction to sink ⁽²⁾	$R_{th(j-s)}$	$\lambda_{paste} = 2,5$ W/mK (HPTP)						1,06		K/W
Dynamic										
Peak recovery current	I_{RM}					25 125 150		77,33 75,64 76,58		A
Reverse recovery time	t_{rr}					25 125 150		157,26 283,67 310,8		ns
Recovered charge	Q_r	$di/dt=2681$ A/μs $di/dt=2670$ A/μs $di/dt=2690$ A/μs	±15	600	35	25 125 150		4,34 6,18 6,9		μC
Reverse recovered energy	E_{rec}					25 125 150		1,96 2,82 3,13		mWs
Peak rate of fall of recovery current	$(di_r/dt)_{max}$					25 125 150		2734 2205 2101		A/μs



Characteristic Values

Parameter	Symbol	Conditions					Values			Unit
		V_{GE} [V] V_{GS} [V]	V_{CE} [V] V_{DS} [V] V_F [V]	I_C [A] I_D [A] I_F [A]	T_j [°C]	Min	Typ	Max		

Brake Switch

Static

Gate-emitter threshold voltage	$V_{GE(th)}$		10	0,0035	25	5,4	6	6,6	V
Collector-emitter saturation voltage	$V_{CE(sat)}$	15		35	25 125 150		1,47 1,64 1,68	1,85 ⁽¹⁾	V
Collector-emitter cut-off current	I_{CES}	0	1200		25			80	μA
Gate-emitter leakage current	I_{GES}	20	0		25			200	nA
Internal gate resistance	r_g						None		Ω
Input capacitance	C_{ies}						7900		pF
Output capacitance	C_{oes}	0	10		25		270		pF
Reverse transfer capacitance	C_{res}						97		pF
Gate charge	Q_g	$V_{CC} = 600$ V	0/15		35	25	260		nC

Thermal

Thermal resistance junction to sink ⁽²⁾	$R_{th(j-s)}$	$\lambda_{paste} = 2,5$ W/mK (HPTP)					0,73		K/W
--	---------------	--	--	--	--	--	------	--	-----

Dynamic

Turn-on delay time	$t_{d(on)}$					25 125 150		124,2 122,4 121,4	ns
Rise time	t_r	$R_{gon} = 8$ Ω $R_{goff} = 8$ Ω				25 125 150		14,2 17 17,8	ns
Turn-off delay time	$t_{d(off)}$		±15	600	35	25 125 150		178,6 202,8 208,2	ns
Fall time	t_f					25 125 150		95,14 117,86 118,79	ns
Turn-on energy (per pulse)	E_{on}	$Q_{tFWD} = 4,34$ μC $Q_{tFWD} = 6,18$ μC $Q_{tFWD} = 6,9$ μC				25 125 150		1,45 1,92 2,09	mWs
Turn-off energy (per pulse)	E_{off}					25 125 150		2,4 3,17 3,42	mWs



Vincotech

80-M212PMA035M7-K220A70
datasheet

Characteristic Values

Parameter	Symbol	Conditions					Values			Unit
		V_{GE} [V] V_{GS} [V]	V_{CE} [V] V_{DS} [V] V_F [V]	I_C [A] I_D [A] I_F [A]	T_j [°C]	Min	Typ	Max		
Brake Diode										
Static										
Forward voltage	V_F				35	25 125 150		1,66 1,76 1,75	2,1 ⁽¹⁾	V
Reverse leakage current	I_R	$V_r = 1200$ V				25			40	μA
Thermal										
Thermal resistance junction to sink ⁽²⁾	$R_{th(j-s)}$	$\lambda_{paste} = 2,5$ W/mK (HPTP)						1,06		K/W
Dynamic										
Peak recovery current	I_{RM}					25 125 150		77,33 75,64 76,58		A
Reverse recovery time	t_{rr}					25 125 150		157,26 283,67 310,8		ns
Recovered charge	Q_r	$di/dt=2681$ A/μs $di/dt=2670$ A/μs $di/dt=2690$ A/μs	±15	600	35	25 125 150		4,34 6,18 6,9		μC
Reverse recovered energy	E_{rec}					25 125 150		1,96 2,82 3,13		mWs
Peak rate of fall of recovery current	$(di_r/dt)_{max}$					25 125 150		2734 2205 2101		A/μs



Characteristic Values

Parameter	Symbol	Conditions					Values			Unit
		V_{GS} [V]	V_{GE} [V]	V_{DS} [V]	V_{CE} [V]	T_j [°C]	Min	Typ	Max	

Rectifier Diode

Static

Forward voltage	V_F				13	25 125		0,988 0,899	1,21 ⁽¹⁾ 1,1 ⁽¹⁾	V
Reverse leakage current	I_R	$V_i = 1600$ V				25			50	μA

Thermal

Thermal resistance junction to sink ⁽²⁾	$R_{th(j-s)}$	$\lambda_{paste} = 2,5$ W/mK (HPTP)						1,1		K/W
--	---------------	--	--	--	--	--	--	-----	--	-----

Thermistor

Static

Rated resistance	R					25		1		kΩ
Deviation of R_{100}	$\Delta_{R/R}$	$R_{100} = 1670$ Ω				100	-2		2	%
Maximum Current	I_{max}							3		mA
Power dissipation constant	d					25		0,76		mW/K
A-value	A							$7,635 \times 10^{-3}$		1/K
B-value	B							$1,73 \times 10^{-5}$		1/K ²
Vincotech Thermistor Reference									E	

⁽¹⁾ Value at chip level

⁽²⁾ Only valid with pre-applied Vincotech thermal interface material.



Inverter Switch Characteristics

figure 1. IGBT

Typical output characteristics

$$I_C = f(V_{CE})$$

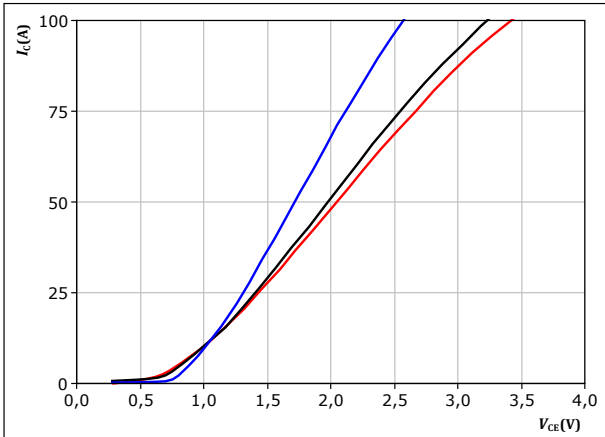

$t_p = 250 \mu s$
 $V_{GE} = 15 V$
 $T_j:$ — 25 °C
 — 125 °C
 — 150 °C

figure 2. IGBT

Typical output characteristics

$$I_C = f(V_{CE})$$

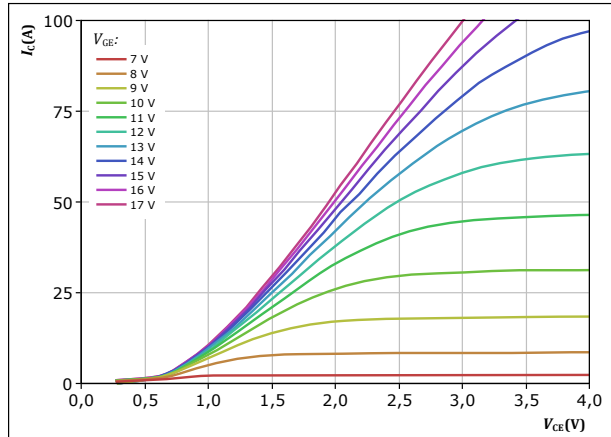

$t_p = 250 \mu s$
 $T_j = 150 \text{ °C}$
 V_{GE} from 7 V to 17 V in steps of 1 V

figure 3. IGBT

Typical transfer characteristics

$$I_C = f(V_{GE})$$

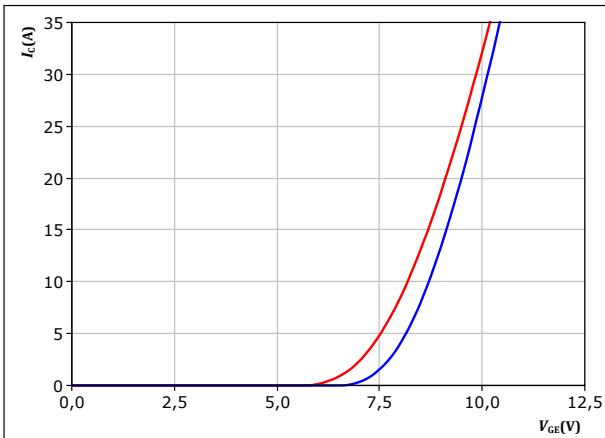

$t_p = 250 \mu s$
 $V_{CE} = 10 V$
 $T_j:$ — 25 °C
 — 125 °C

figure 4. IGBT

Transient thermal impedance as a function of pulse width

$$Z_{th(j-s)} = f(t_p)$$

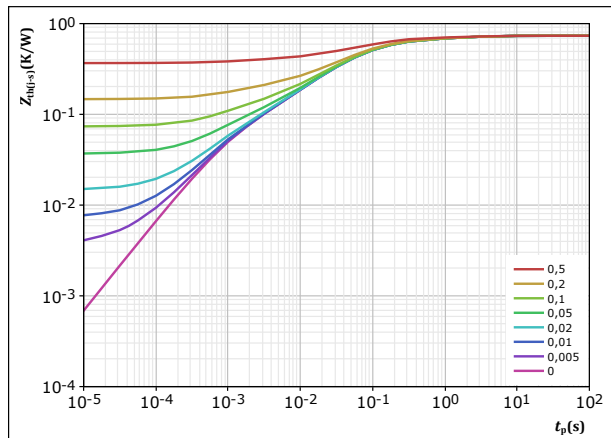

$D = t_p / T$
 $R_{th(j-s)} = 0,734 \text{ K/W}$
 IGBT thermal model values

R (K/W)	τ (s)
4,86E-02	2,88E+00
1,00E-01	4,81E-01
3,87E-01	7,10E-02
1,44E-01	1,25E-02
5,43E-02	1,05E-03



Inverter Switch Characteristics

figure 5. IGBT

Safe operating area
 $I_C = f(V_{CE})$

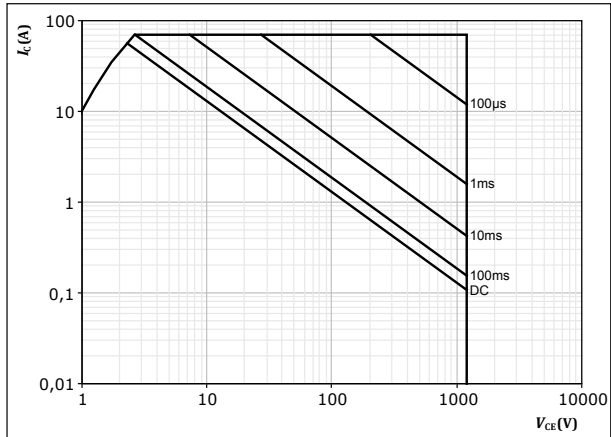

$D =$ single pulse
 $T_s = 80 \text{ } ^\circ\text{C}$
 $V_{GE} = 15 \text{ V}$
 $T_j = T_{jmax}$

figure 6. IGBT

Gate voltage vs gate charge
 $V_{GE} = f(Q_g)$

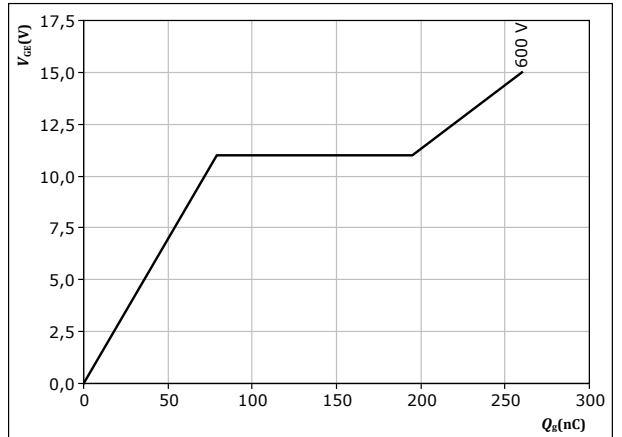

$I_C = 35 \text{ A}$
 $T_j = 25 \text{ } ^\circ\text{C}$



Inverter Diode Characteristics

figure 7. FWD

Typical forward characteristics

$$I_F = f(V_F)$$

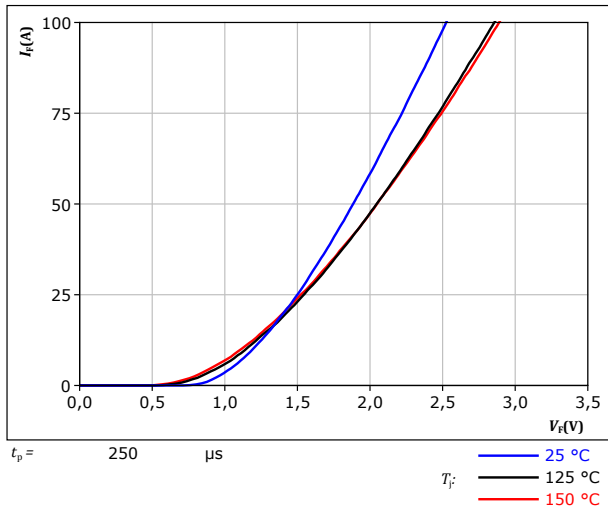
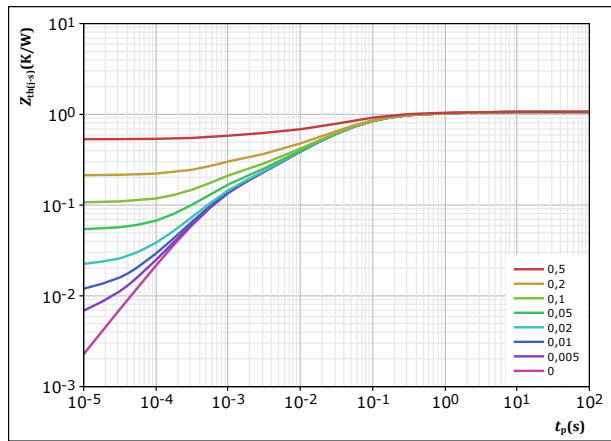

figure 8. FWD

Transient thermal impedance as a function of pulse width

$$Z_{th(j-s)} = f(t_p)$$



$D = t_p / T$
 $R_{th(j-s)} = 1,064 \text{ K/W}$
 FWD thermal model values

R (K/W)	τ (s)
6,06E-02	1,82E+00
2,37E-01	1,58E-01
4,33E-01	3,97E-02
2,08E-01	7,61E-03
1,26E-01	6,66E-04



Brake Switch Characteristics

figure 9. IGBT

Typical output characteristics
 $I_C = f(V_{CE})$

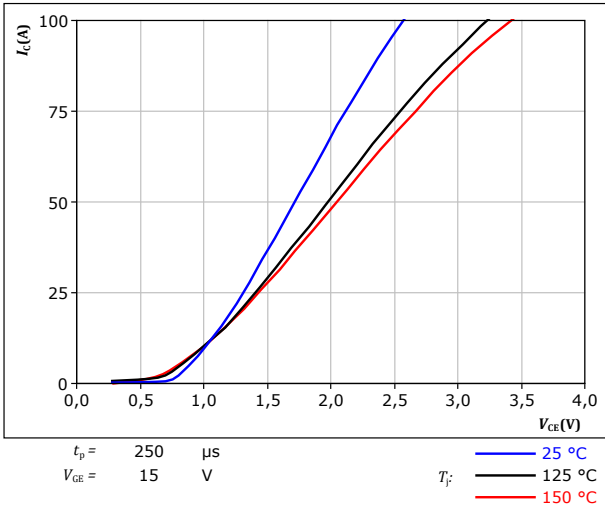

figure 10. IGBT

Typical output characteristics
 $I_C = f(V_{CE})$

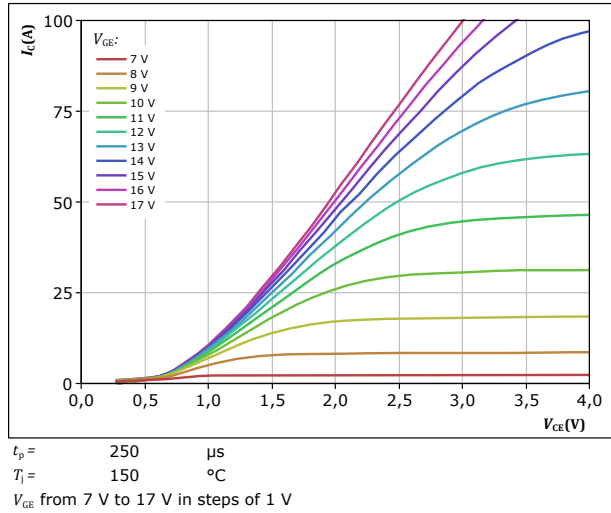

figure 11. IGBT

Typical transfer characteristics
 $I_C = f(V_{GE})$

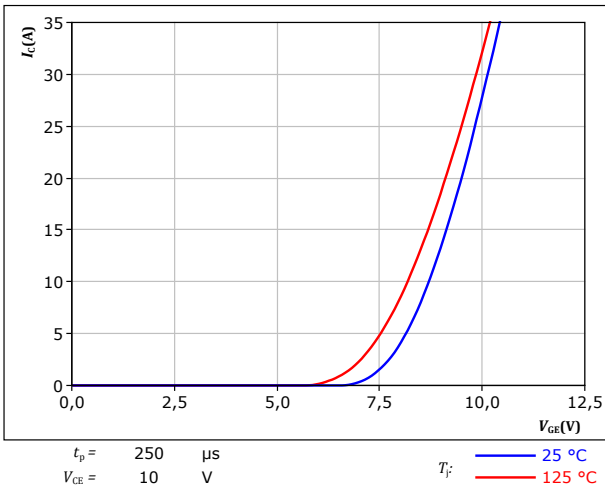
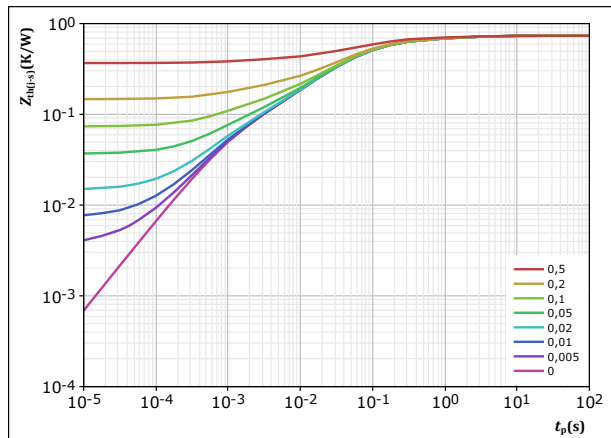

figure 12. IGBT

Transient thermal impedance as a function of pulse width
 $Z_{th(j-s)} = f(t_p)$



IGBT thermal model values

R (K/W)	τ (s)
4,86E-02	2,88E+00
1,00E-01	4,81E-01
3,87E-01	7,10E-02
1,44E-01	1,25E-02
5,43E-02	1,05E-03



Brake Switch Characteristics

figure 13. IGBT

Safe operating area

$I_C = f(V_{CE})$

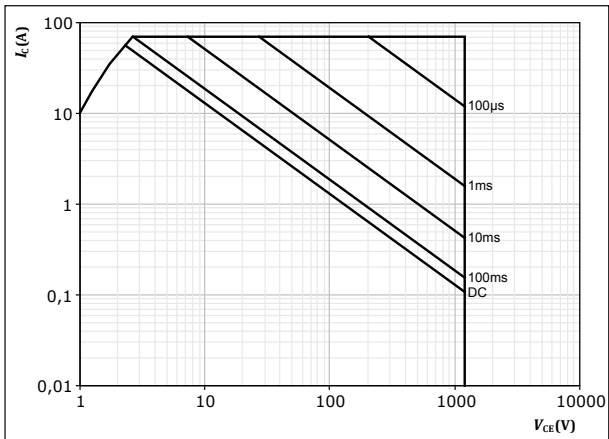

$D =$ single pulse
 $T_s = 80 \text{ } ^\circ\text{C}$
 $V_{GE} = 15 \text{ V}$
 $T_j = T_{jmax}$

figure 14. IGBT

Gate voltage vs gate charge

$V_{GE} = f(Q_g)$

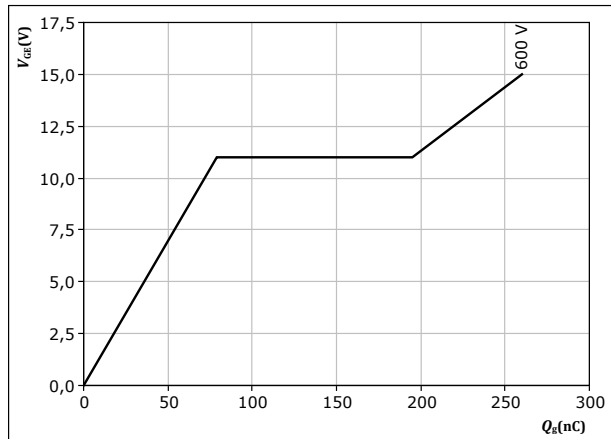

$I_C = 35 \text{ A}$
 $T_j = 25 \text{ } ^\circ\text{C}$



Brake Diode Characteristics

figure 15. FWD

Typical forward characteristics

$$I_F = f(V_F)$$

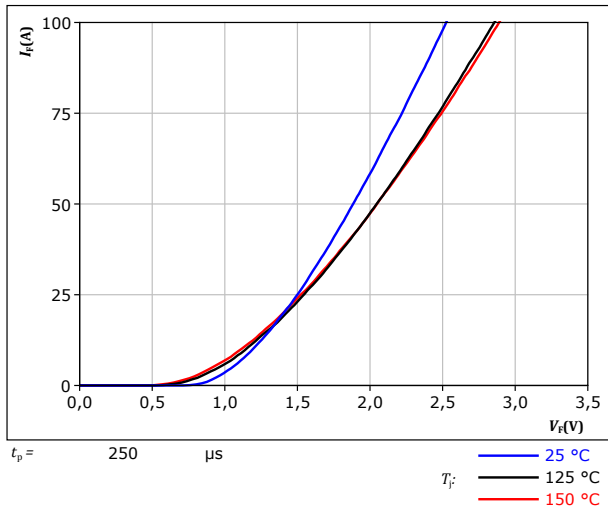
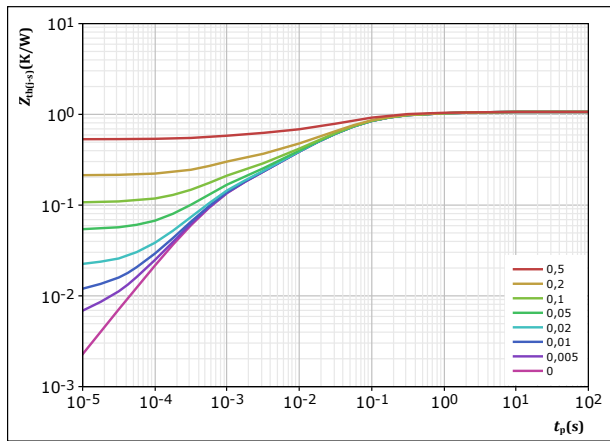

figure 16. FWD

Transient thermal impedance as a function of pulse width

$$Z_{th(j-s)} = f(t_p)$$



$D =$	t_p / T	
$R_{th(j-s)} =$	1,064	K/W
FWD thermal model values		
R (K/W)	τ (s)	
6,06E-02	1,82E+00	
2,37E-01	1,58E-01	
4,33E-01	3,97E-02	
2,08E-01	7,61E-03	
1,26E-01	6,66E-04	



Rectifier Diode Characteristics

figure 17. Rectifier

Typical forward characteristics

$$I_F = f(V_F)$$

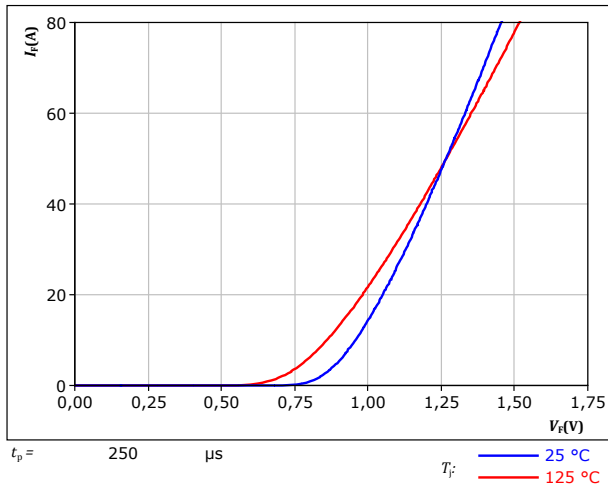
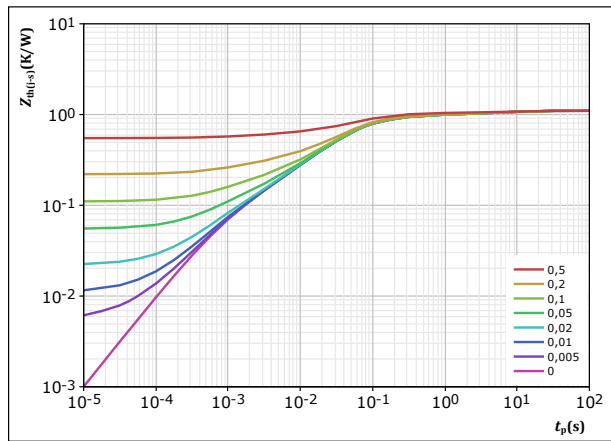

figure 18. Rectifier

Transient thermal impedance as a function of pulse width

$$Z_{th(j-s)} = f(t_p)$$



$D = t_p / T$
 $R_{th(j-s)} = 1,1$ K/W

Rectifier thermal model values

R (K/W)	τ (s)
1,03E-01	7,70E+00
1,17E-01	4,31E-01
5,19E-01	6,42E-02
2,38E-01	2,35E-02
7,64E-02	3,81E-03
4,71E-02	7,57E-04



Thermistor Characteristics

figure 19. Thermistor

Typical PTC characteristic as function of temperature
 $R_T = f(T)$

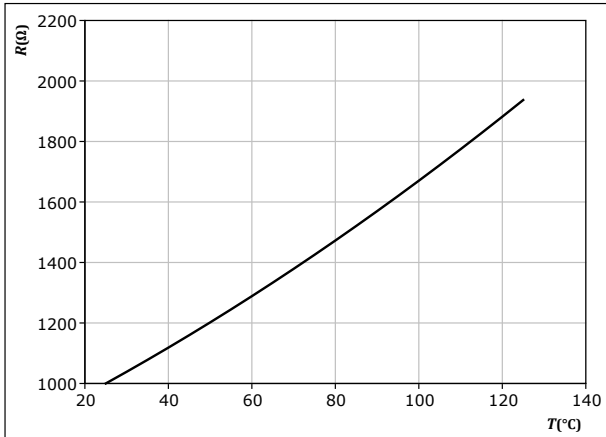



Inverter Switching Characteristics

figure 20. IGBT

Typical switching energy losses as a function of collector current
 $E = f(I_c)$

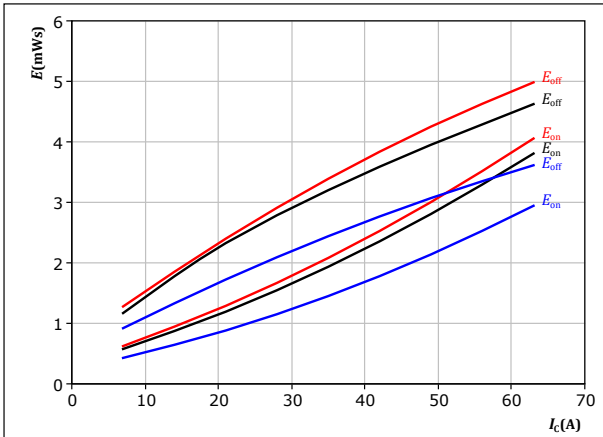

With an inductive load at
 $V_{CE} = 600$ V
 $V_{GE} = \pm 15$ V
 $R_{gon} = 8$ Ω
 $R_{goff} = 8$ Ω

T_j : — 25 °C
 — 125 °C
 — 150 °C

figure 21. IGBT

Typical switching energy losses as a function of IGBT turn on gate resistor
 $E = f(R_g)$

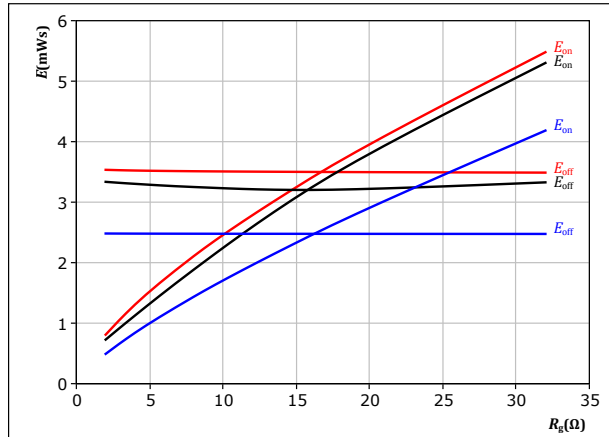

With an inductive load at
 $V_{CE} = 600$ V
 $V_{GE} = \pm 15$ V
 $I_c = 35$ A

T_j : — 25 °C
 — 125 °C
 — 150 °C

figure 22. FWD

Typical reverse recovered energy loss as a function of collector current
 $E_{rec} = f(I_c)$

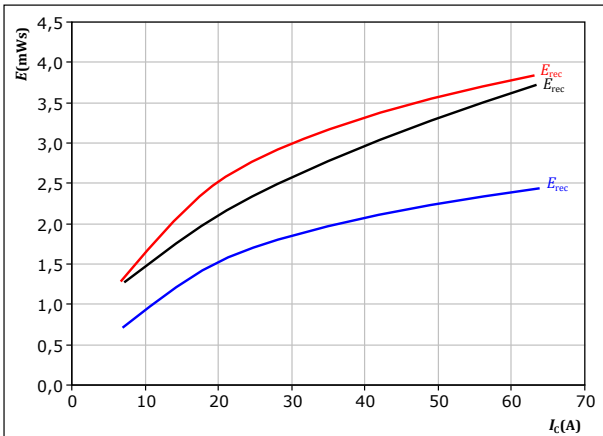

With an inductive load at
 $V_{CE} = 600$ V
 $V_{GE} = \pm 15$ V
 $R_{gon} = 8$ Ω

T_j : — 25 °C
 — 125 °C
 — 150 °C

figure 23. FWD

Typical reverse recovered energy loss as a function of IGBT turn on gate resistor
 $E_{rec} = f(R_g)$

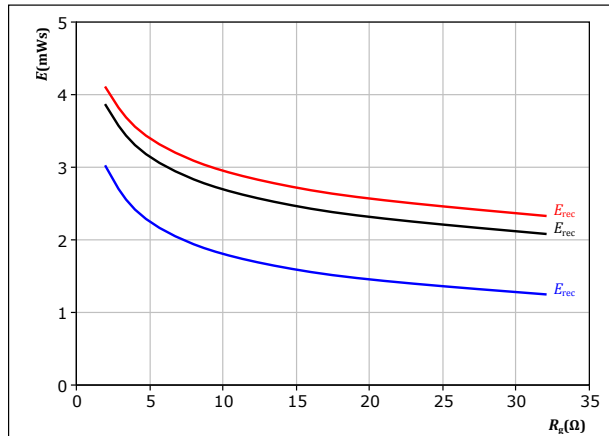

With an inductive load at
 $V_{CE} = 600$ V
 $V_{GE} = \pm 15$ V
 $I_c = 35$ A

T_j : — 25 °C
 — 125 °C
 — 150 °C



Inverter Switching Characteristics

figure 24. IGBT

Typical switching times as a function of collector current
 $t = f(I_c)$

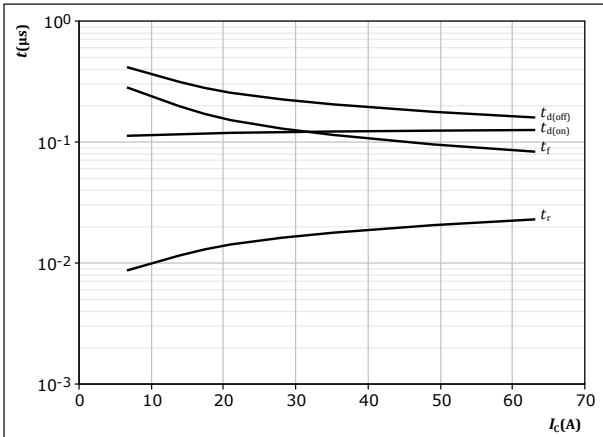

With an inductive load at

- T_j = 150 °C
- V_{CE} = 600 V
- V_{GE} = ±15 V
- R_{gon} = 8 Ω
- R_{goff} = 8 Ω

figure 25. IGBT

Typical switching times as a function of IGBT turn on gate resistor
 $t = f(R_g)$

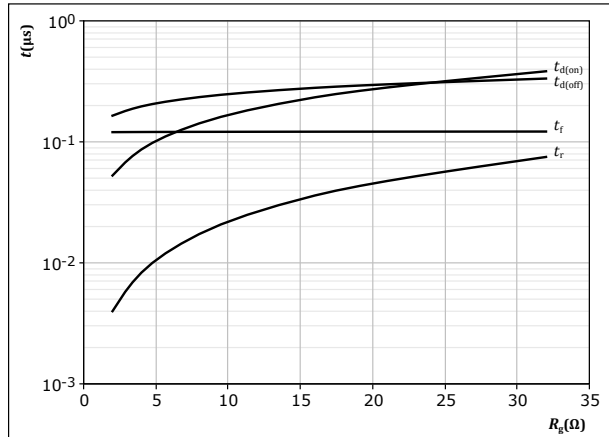

With an inductive load at

- T_j = 150 °C
- V_{CE} = 600 V
- V_{GE} = ±15 V
- I_c = 35 A

figure 26. FWD

Typical reverse recovery time as a function of collector current
 $t_{rr} = f(I_c)$

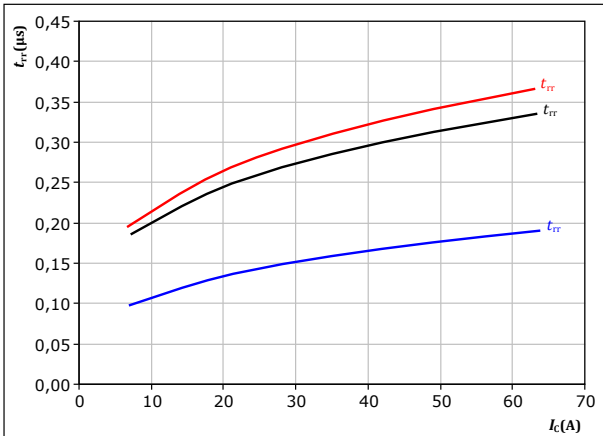

With an inductive load at

- V_{CE} = 600 V
- V_{GE} = ±15 V
- R_{gon} = 8 Ω

- 25 °C
- 125 °C
- 150 °C

figure 27. FWD

Typical reverse recovery time as a function of IGBT turn on gate resistor
 $t_{rr} = f(R_{gon})$

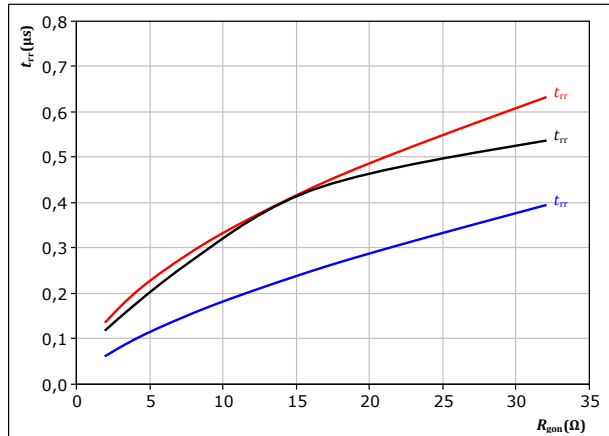

With an inductive load at

- V_{CE} = 600 V
- V_{GE} = ±15 V
- I_c = 35 A

- 25 °C
- 125 °C
- 150 °C



Inverter Switching Characteristics

figure 28. FWD

Typical recovered charge as a function of collector current

$$Q_r = f(I_c)$$

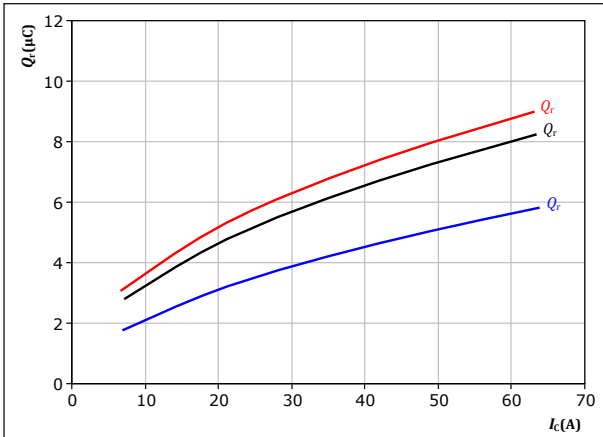

With an inductive load at

$V_{CE} = 600$ V
 $V_{GE} = \pm 15$ V
 $R_{gon} = 8$ Ω

T_j : — 25 °C
 — 125 °C
 — 150 °C

figure 29. FWD

Typical recovered charge as a function of IGBT turn on gate resistor

$$Q_r = f(R_{gon})$$

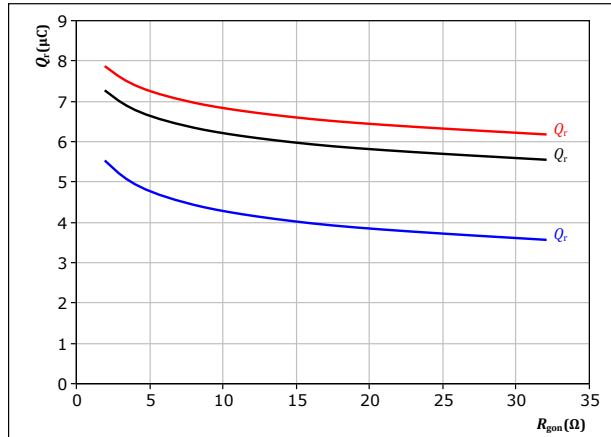

With an inductive load at

$V_{CE} = 600$ V
 $V_{GE} = \pm 15$ V
 $I_c = 35$ A

T_j : — 25 °C
 — 125 °C
 — 150 °C

figure 30. FWD

Typical peak reverse recovery current as a function of collector current

$$I_{RM} = f(I_c)$$

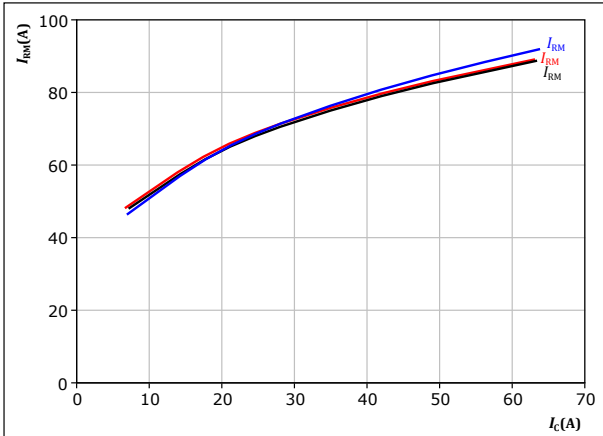

With an inductive load at

$V_{CE} = 600$ V
 $V_{GE} = \pm 15$ V
 $R_{gon} = 8$ Ω

T_j : — 25 °C
 — 125 °C
 — 150 °C

figure 31. FWD

Typical peak reverse recovery current as a function of IGBT turn on gate resistor

$$I_{RM} = f(R_{gon})$$

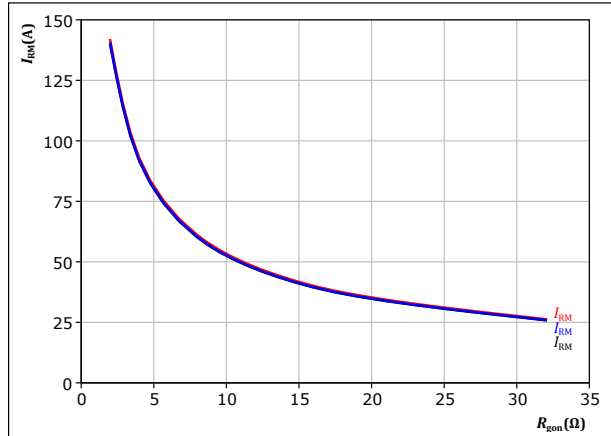

With an inductive load at

$V_{CE} = 600$ V
 $V_{GE} = \pm 15$ V
 $I_c = 35$ A

T_j : — 25 °C
 — 125 °C
 — 150 °C



Inverter Switching Characteristics

figure 32. FWD

Typical rate of fall of forward and reverse recovery current as a function of collector current
 $di_f/dt, di_r/dt = f(I_C)$

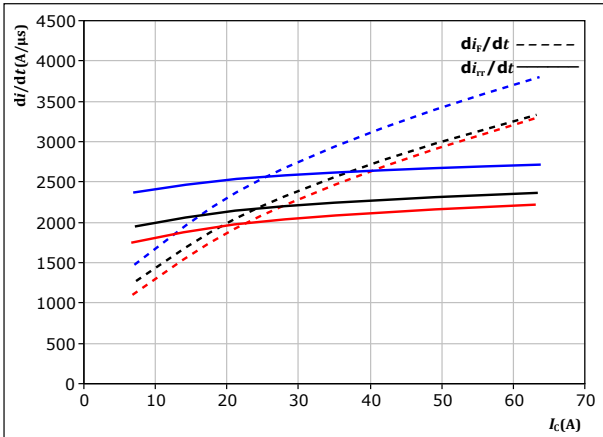

With an inductive load at

$V_{CE} = 600 \text{ V}$
 $V_{GE} = \pm 15 \text{ V}$
 $R_{gon} = 8 \ \Omega$

$T_j:$ — 25 °C
 — 125 °C
 — 150 °C

figure 33. FWD

Typical rate of fall of forward and reverse recovery current as a function of turn on gate resistor
 $di_f/dt, di_r/dt = f(R_{gon})$

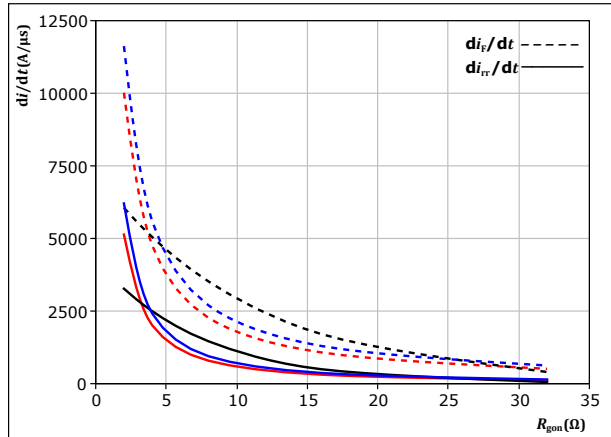

With an inductive load at

$V_{CE} = 600 \text{ V}$
 $V_{GE} = \pm 15 \text{ V}$
 $I_C = 35 \text{ A}$

$T_j:$ — 25 °C
 — 125 °C
 — 150 °C

figure 34. IGBT

Reverse bias safe operating area

$I_C = f(V_{CE})$

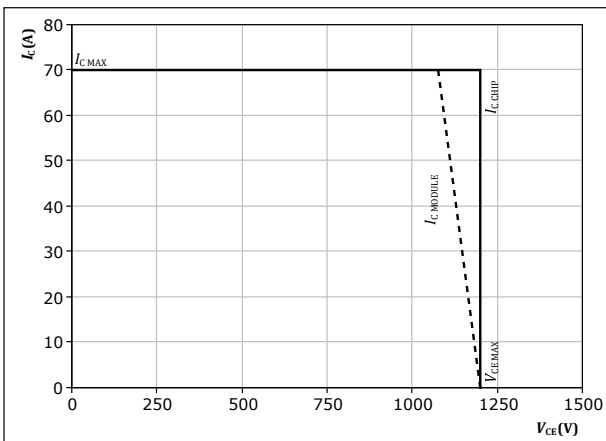

At $T_j = 150 \text{ °C}$
 $R_{gon} = 8 \ \Omega$
 $R_{goff} = 8 \ \Omega$



Brake Switching Characteristics

figure 35. IGBT

Typical switching energy losses as a function of collector current
 $E = f(I_c)$

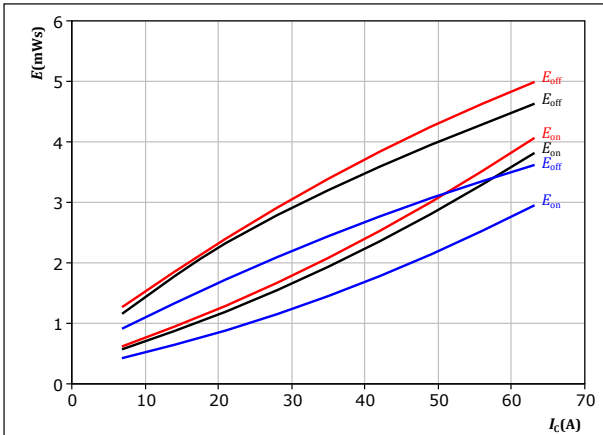

With an inductive load at
 $V_{CE} = 600 \text{ V}$
 $V_{GE} = \pm 15 \text{ V}$
 $R_{gon} = 8 \ \Omega$
 $R_{goff} = 8 \ \Omega$

T_j : — 25 °C
 — 125 °C
 — 150 °C

figure 36. IGBT

Typical switching energy losses as a function of IGBT turn on gate resistor
 $E = f(R_g)$

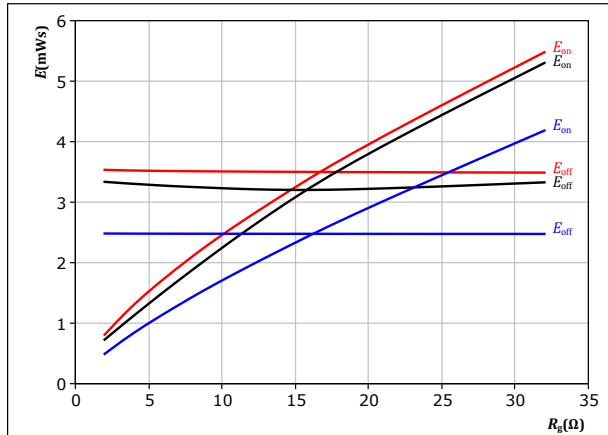

With an inductive load at
 $V_{CE} = 600 \text{ V}$
 $V_{GE} = \pm 15 \text{ V}$
 $I_c = 35 \text{ A}$

T_j : — 25 °C
 — 125 °C
 — 150 °C

figure 37. FWD

Typical reverse recovered energy loss as a function of collector current
 $E_{rec} = f(I_c)$

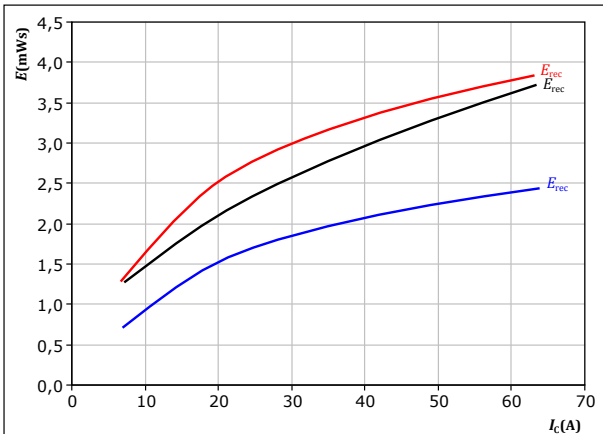

With an inductive load at
 $V_{CE} = 600 \text{ V}$
 $V_{GE} = \pm 15 \text{ V}$
 $R_{gon} = 8 \ \Omega$

T_j : — 25 °C
 — 125 °C
 — 150 °C

figure 38. FWD

Typical reverse recovered energy loss as a function of IGBT turn on gate resistor
 $E_{rec} = f(R_g)$

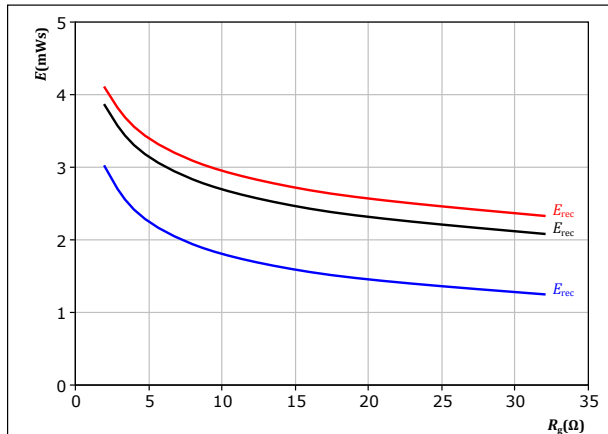

With an inductive load at
 $V_{CE} = 600 \text{ V}$
 $V_{GE} = \pm 15 \text{ V}$
 $I_c = 35 \text{ A}$

T_j : — 25 °C
 — 125 °C
 — 150 °C



Brake Switching Characteristics

figure 39. IGBT

Typical switching times as a function of collector current
 $t = f(I_c)$

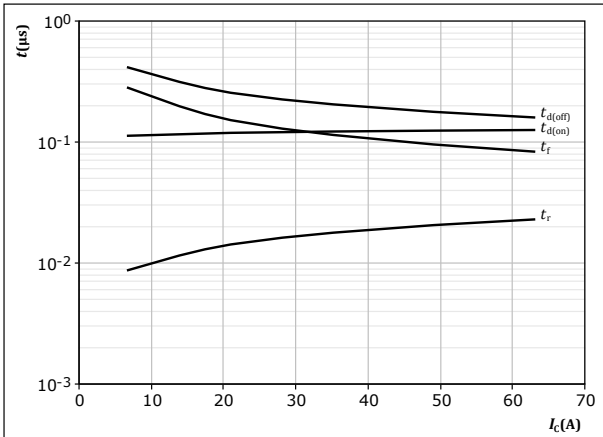

With an inductive load at

$T_j = 150 \text{ }^\circ\text{C}$
 $V_{CE} = 600 \text{ V}$
 $V_{GE} = \pm 15 \text{ V}$
 $R_{gon} = 8 \text{ } \Omega$
 $R_{goff} = 8 \text{ } \Omega$

figure 40. IGBT

Typical switching times as a function of IGBT turn on gate resistor
 $t = f(R_g)$

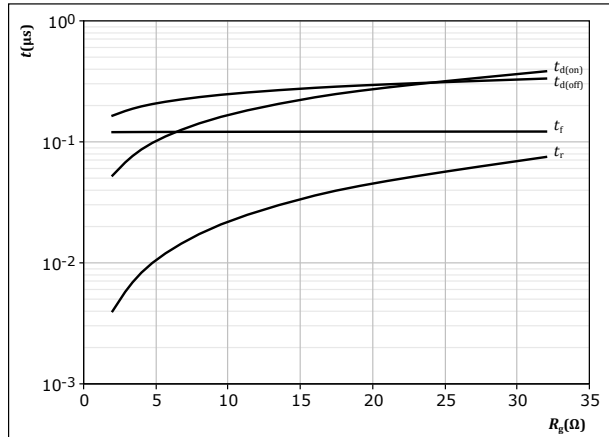

With an inductive load at

$T_j = 150 \text{ }^\circ\text{C}$
 $V_{CE} = 600 \text{ V}$
 $V_{GE} = \pm 15 \text{ V}$
 $I_c = 35 \text{ A}$

figure 41. FWD

Typical reverse recovery time as a function of collector current
 $t_{rr} = f(I_c)$

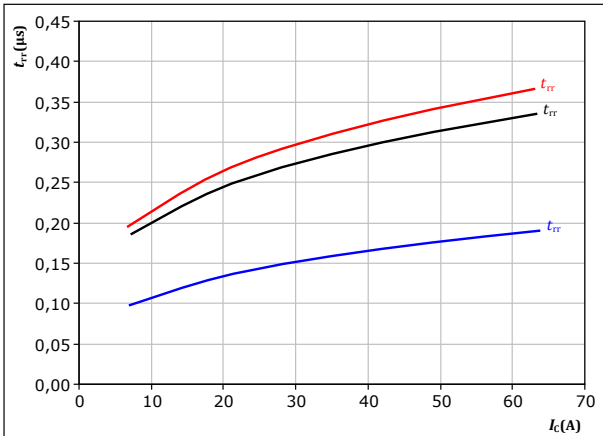

With an inductive load at

$V_{CE} = 600 \text{ V}$
 $V_{GE} = \pm 15 \text{ V}$
 $R_{gon} = 8 \text{ } \Omega$

T_j : — 25 °C
— 125 °C
— 150 °C

figure 42. FWD

Typical reverse recovery time as a function of IGBT turn on gate resistor
 $t_{rr} = f(R_{gon})$

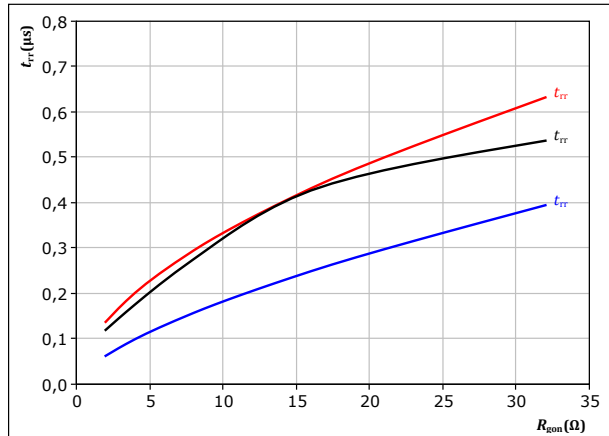

With an inductive load at

$V_{CE} = 600 \text{ V}$
 $V_{GE} = \pm 15 \text{ V}$
 $I_c = 35 \text{ A}$

T_j : — 25 °C
— 125 °C
— 150 °C



Brake Switching Characteristics

figure 43. FWD

Typical recovered charge as a function of collector current

$$Q_r = f(I_c)$$

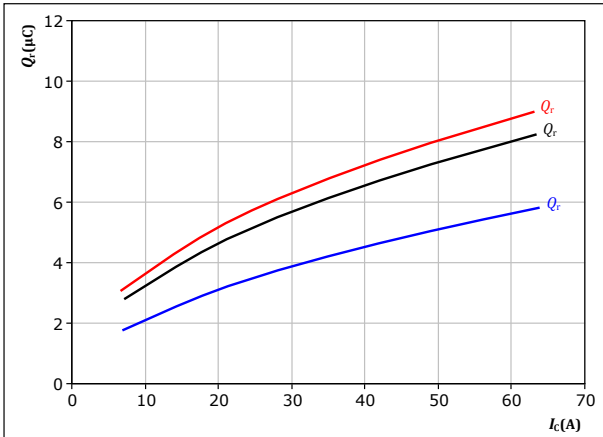

With an inductive load at

$V_{CE} = 600$ V
 $V_{GE} = \pm 15$ V
 $R_{gon} = 8$ Ω

T_j : — 25 °C
 — 125 °C
 — 150 °C

figure 44. FWD

Typical recovered charge as a function of IGBT turn on gate resistor

$$Q_r = f(R_{gon})$$

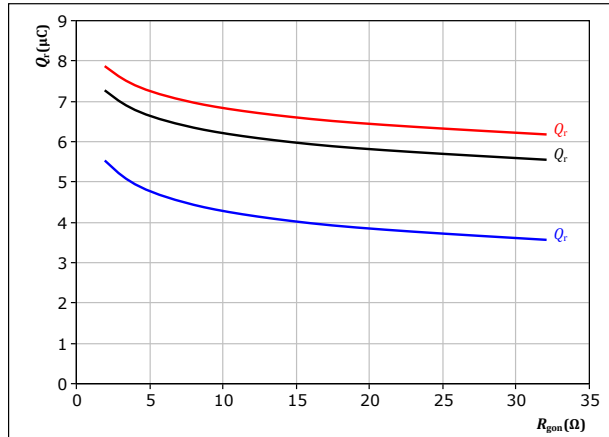

With an inductive load at

$V_{CE} = 600$ V
 $V_{GE} = \pm 15$ V
 $I_c = 35$ A

T_j : — 25 °C
 — 125 °C
 — 150 °C

figure 45. FWD

Typical peak reverse recovery current as a function of collector current

$$I_{RM} = f(I_c)$$

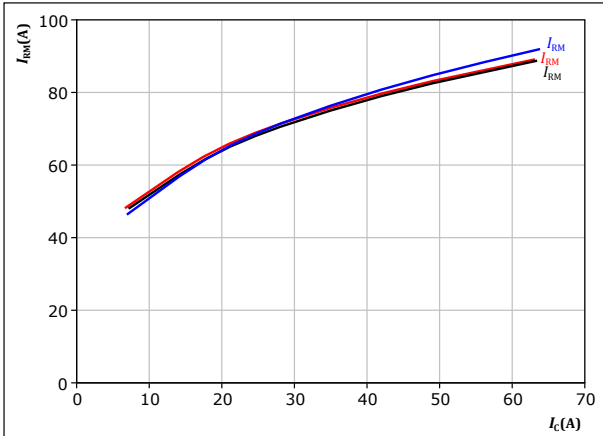

With an inductive load at

$V_{CE} = 600$ V
 $V_{GE} = \pm 15$ V
 $R_{gon} = 8$ Ω

T_j : — 25 °C
 — 125 °C
 — 150 °C

figure 46. FWD

Typical peak reverse recovery current as a function of IGBT turn on gate resistor

$$I_{RM} = f(R_{gon})$$

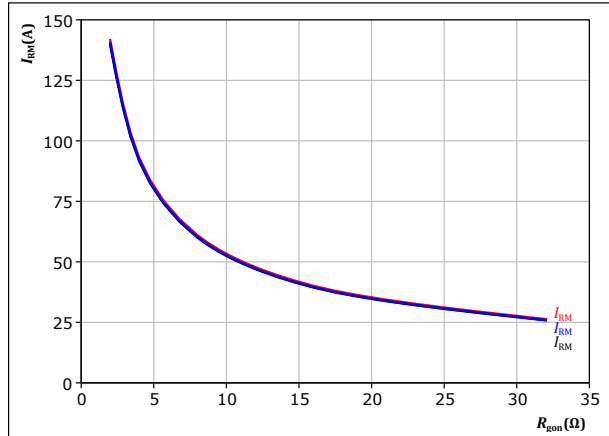

With an inductive load at

$V_{CE} = 600$ V
 $V_{GE} = \pm 15$ V
 $I_c = 35$ A

T_j : — 25 °C
 — 125 °C
 — 150 °C



Brake Switching Characteristics

figure 47. FWD

Typical rate of fall of forward and reverse recovery current as a function of collector current
 $di_f/dt, di_r/dt = f(I_C)$

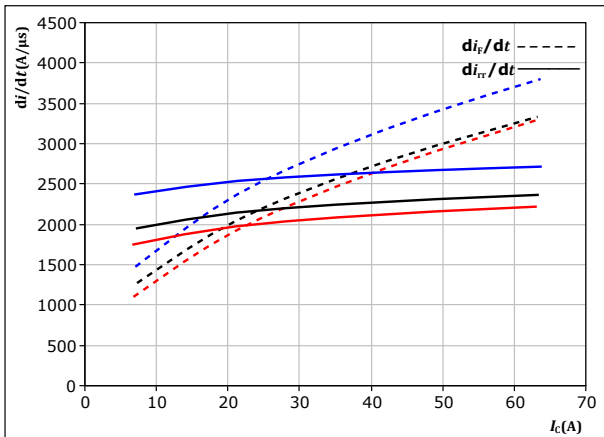

With an inductive load at

$V_{CE} = 600 \text{ V}$
 $V_{GE} = \pm 15 \text{ V}$
 $R_{gon} = 8 \ \Omega$

$T_j:$
— 25 °C
— 125 °C
— 150 °C

figure 48. FWD

Typical rate of fall of forward and reverse recovery current as a function of turn on gate resistor
 $di_f/dt, di_r/dt = f(R_{gon})$

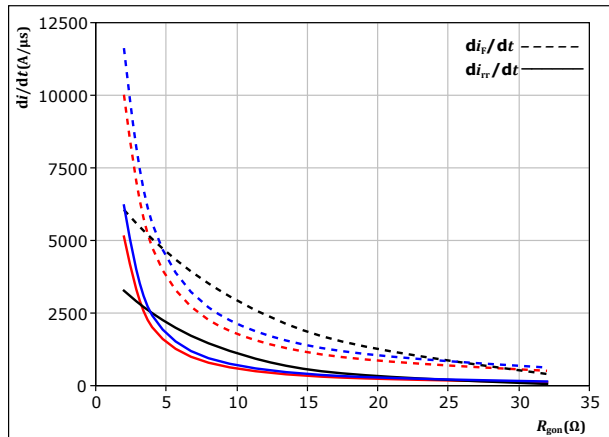

With an inductive load at

$V_{CE} = 600 \text{ V}$
 $V_{GE} = \pm 15 \text{ V}$
 $I_C = 35 \text{ A}$

$T_j:$
— 25 °C
— 125 °C
— 150 °C

figure 49. IGBT

Reverse bias safe operating area

$I_C = f(V_{CE})$

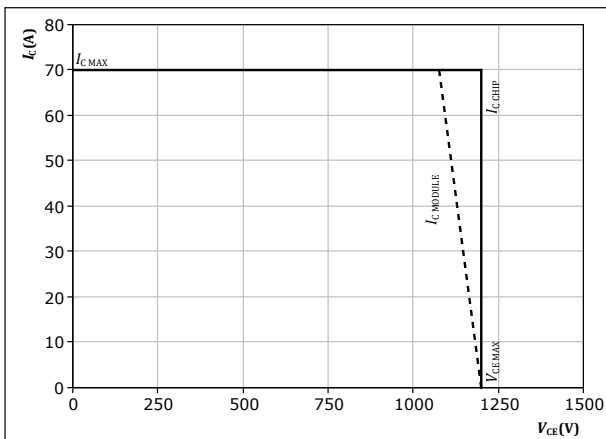

At $T_j = 150 \text{ °C}$
 $R_{gon} = 8 \ \Omega$
 $R_{goff} = 8 \ \Omega$



Switching Definitions

figure 50. IGBT

Turn-off Switching Waveforms & definition of t_{doff} , t_{Eoff} (t_{Eoff} = integrating time for E_{off})

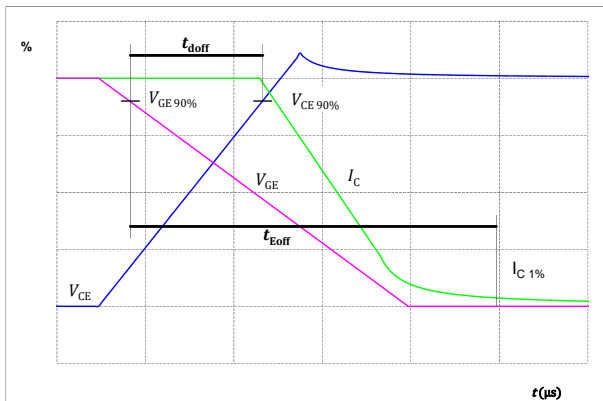

figure 51. IGBT

Turn-on Switching Waveforms & definition of t_{don} , t_{Eon} (t_{Eon} = integrating time for E_{on})

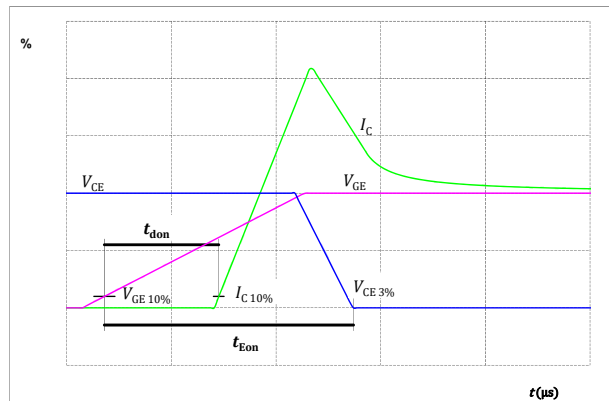

figure 52. IGBT

Turn-off Switching Waveforms & definition of t_f

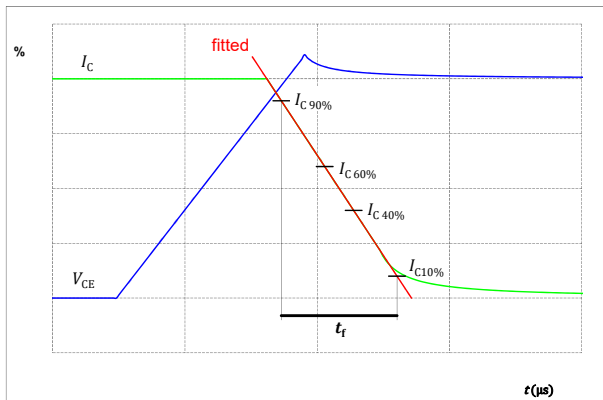
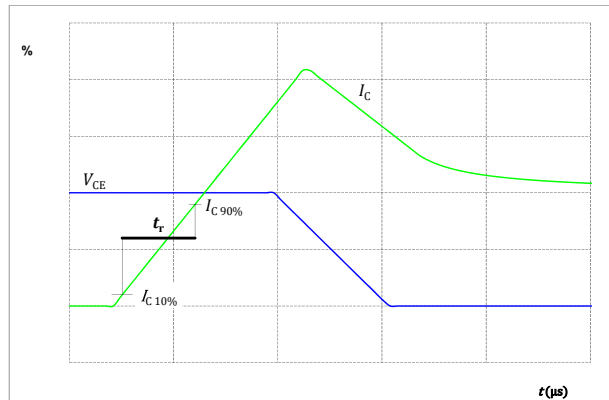

figure 53. IGBT

Turn-on Switching Waveforms & definition of t_r





Switching Definitions

figure 54. FWD

Turn-off Switching Waveforms & definition of t_{rr}

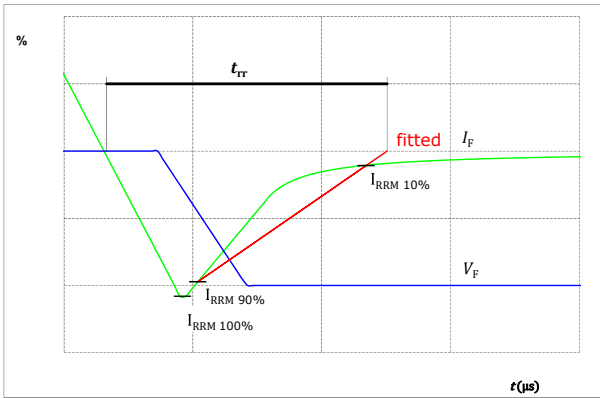
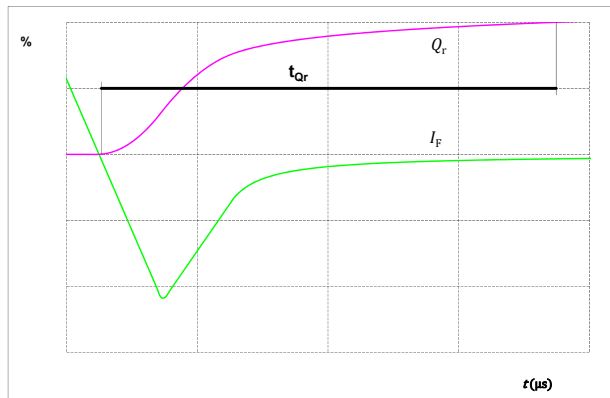



figure 55. FWD

Turn-on Switching Waveforms & definition of t_{Qr} (t_{Qr} = integrating time for Q_r)





Ordering Code	
Version	Ordering Code
With std lid (6.5mm height) + no thermal grease	80-M212PMA035M7-K220A70-/0A/
With thin lid (2.8mm height) + no thermal grease	80-M212PMA035M7-K220A70-/0B/
With std lid (6.5mm height) + thermal grease (0,8 W/mK, P12, silicone-based)	80-M212PMA035M7-K220A70-/1A/
With thin lid (2.8mm height) + thermal grease (0,8 W/mK, P12, silicone-based)	80-M212PMA035M7-K220A70-/1B/
With std lid (6.5mm height) + thermal grease (2,5 W/mK, TG20032, silicone-free)	80-M212PMA035M7-K220A70-/4A/
With thin lid (2.8mm height) + thermal grease (2,5 W/mK, TG20032, silicone-free)	80-M212PMA035M7-K220A70-/4B/
With std lid (6.5mm height) + thermal grease (2,5 W/mK, HPTP, silicone-based)	80-M212PMA035M7-K220A70-/5A/
With thin lid (2.8mm height) + thermal grease (2,5 W/mK, HPTP, silicone-based)	80-M212PMA035M7-K220A70-/5B/

Marking						
Text	Name		Date code	UL & VIN	Lot	Serial
		NN-NNNNNNNNNNNNNN- TTTTTTTV		WWYY	UL VIN	LLLLL
Datamatrix		Type&Ver TTTTTTTV	Lot number LLLLL	Serial SSSS	Date code WWYY	

Outline							
Pin table [mm]							
Pin	X	Y	Function	34	0,03	5,8	Br
1	24,38	-21,8	G16	35	0,03	9	Br
2	24,38	-18,6	S16	36	not assembled		
3	24,38	-15,4	Ph3	37	not assembled		
4	not assembled			38	0,03	18,6	DC-Br
5	24,38	-9	Ph3	39	0,03	21,8	G27
6	not assembled			40	-8,5	-21,8	DC+Rect
7	not assembled			41	-8,5	-18,6	DC+Rect
8	24,38	12,2	G15	42	not assembled		
9	not assembled			43	-8,5	-12,2	DC+Inv
10	24,38	18,6	Therm2	44	not assembled		
11	24,38	21,8	Therm1	45	-12,22	-5,8	DC+Inv
12	16,58	12,2	G13	46	-12,22	0,7	DC+Br
13	16,58	15,4	DC-Inv	47	not assembled		
14	not assembled			48	-12,22	7,1	DC+Br
15	16,58	21,8	DC-Inv	49	not assembled		
16	13,42	-21,8	G14	50	-12,22	15,4	DC-Rect
17	not assembled			51	not assembled		
18	13,42	-15,4	S14	52	-12,22	21,8	DC-Rect
19	13,42	-12,2	Ph2	53	-24,38	-21,8	ACIn3
20	not assembled			54	not assembled		
21	13,42	-5,8	Ph2	55	-24,38	-15,4	ACIn3
22	not assembled			56	not assembled		
23	not assembled			57	not assembled		
24	8,38	12,2	G11	58	not assembled		
25	8,38	15,4	Se	59	-24,38	-2,5	ACIn2
26	not assembled			60	not assembled		
27	8,38	21,8	DC-Br	61	-24,38	3,9	ACIn2
28	2,46	-21,8	G12	62	not assembled		
29	not assembled			63	-24,38	15,4	ACIn1
30	2,46	-15,4	S12	64	not assembled		
31	2,46	-12,2	Ph1	65	-24,38	21,8	ACIn1
32	not assembled						
33	2,46	-5,8	Ph1				

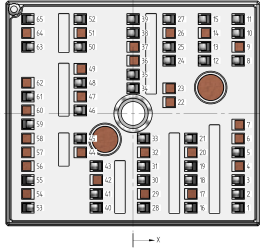

Pad positions refers to center point. For more informations on pad design please see package data



Vincotech

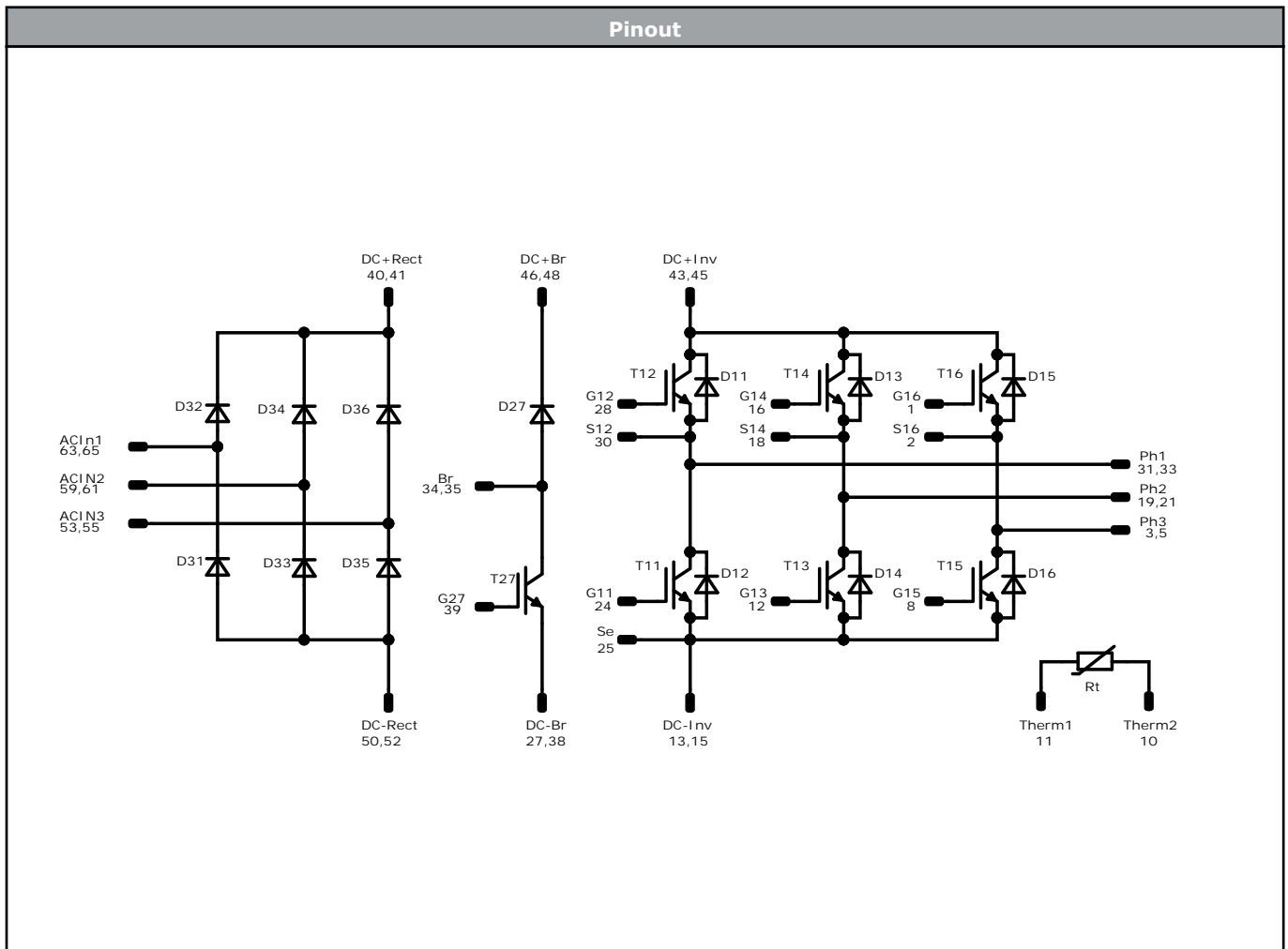

Identification					
ID	Component	Voltage	Current	Function	Comment
T11, T12, T13, T14, T15, T16	IGBT	1200 V	35 A	Inverter Switch	
D11, D12, D13, D14, D15, D16	FWD	1200 V	35 A	Inverter Diode	
T27	IGBT	1200 V	35 A	Brake Switch	
D27	FWD	1200 V	35 A	Brake Diode	
D31, D32, D33, D34, D35, D36	Rectifier	1600 V	35 A	Rectifier Diode	
Rt	PTC			Thermistor	



Packaging instruction				
Standard packaging quantity (SPQ) 72	>SPQ	Standard	<SPQ	Sample

Handling instruction
Handling instructions for MiniSKiiP® 2 packages see vincotech.com website.

Package data
Package data for MiniSKiiP® 2 packages see vincotech.com website.

Vincotech thermistor reference
See Vincotech thermistor reference table at vincotech.com website.

UL recognition and file number
This device is certified according to UL 1557 standard, UL file number E192116. For more information see vincotech.com website. 

Document No.:	Date:	Modification:	Pages
80-M212PMA035M7-K220A70-D3-14	13 Oct. 2022	Correction of gate charge curves from uC to nC	

DISCLAIMER

The information, specifications, procedures, methods and recommendations herein (together "information") are presented by Vincotech to reader in good faith, are believed to be accurate and reliable, but may well be incomplete and/or not applicable to all conditions or situations that may exist or occur. Vincotech reserves the right to make any changes without further notice to any products to improve reliability, function or design. No representation, guarantee or warranty is made to reader as to the accuracy, reliability or completeness of said information or that the application or use of any of the same will avoid hazards, accidents, losses, damages or injury of any kind to persons or property or that the same will not infringe third parties rights or give desired results. It is reader's sole responsibility to test and determine the suitability of the information and the product for reader's intended use.

LIFE SUPPORT POLICY

Vincotech products are not authorised for use as critical components in life support devices or systems without the express written approval of Vincotech.

As used herein:

1. Life support devices or systems are devices or systems which, (a) are intended for surgical implant into the body, or (b) support or sustain life, or (c) whose failure to perform when properly used in accordance with instructions for use provided in labelling can be reasonably expected to result in significant injury to the user.
2. A critical component is any component of a life support device or system whose failure to perform can be reasonably expected to cause the failure of the life support device or system, or to affect its safety or effectiveness.