



Vincotech

# Quick Start Guide for Current Synthesizing PFC reference design

1	Objective .....	4
2	The functional blocks of the Evaluation Board.....	4
3	The power module .....	5
4	Short introduction of the board.....	6
5	Absolute maximum ratings .....	7
6	Starting the evaluation board .....	8
6.1	Interface of the output inverter .....	12
7	Schematic of the evaluation board .....	14
7.1	Main board .....	14
7.2	AUX PS card.....	28
7.3	MUX GD card .....	29
7.4	INV GD PS card .....	30
8	BOM.....	31
8.1	Main card .....	31
8.2	AUX PS card.....	35
8.3	INV GD PS card .....	37
8.4	MUX GD card .....	37

<b>Date</b>	<b>Revision Level</b>	<b>Description</b>	<b>Page Number(s)</b>
2024.01.08	1	First Release	38

Viktor Antoni, Sr. Development Engineer - Application & Concept, Vincotech, Bicske, Hungary

**Disclaimer:**

The information in this document is given as an indication for the purpose of implementation only and shall not be regarded as any description or warranty of a certain functionality, condition or quality. The statements contained herein, including any recommendation, suggestion or methodology, are to be verified by the user before implementation, as operating conditions and environmental factors may vary. It shall be the sole responsibility of the recipient of this document to verify any function described herein in the given practical application. Vincotech GmbH hereby disclaims any and all warranties and liabilities of any kind (including without limitation warranties of non-infringement of intellectual property rights of any third party) with respect to any and all information given in this document.



## Safety Information

*This board classified as an evaluation board (EVA board) dedicated for laboratory environment only. The board should not be used for reliability testing and may not fulfill all relevant standards and requirements by the customer's country. This should be ensured by the customer.*

*It operates at high voltages. This board must be operated by qualified and skilled personnel familiar with all applicable safety standards.*

*This EVA board can endanger life by exposure to high voltages.*

*The device may reach high temperatures that might lead to injury.*

*Allow at least 4 minutes for the DC-Link capacitor to discharge to safe voltage levels (< 50 V). The voltage of the DC-link always should be checked before touching the evaluation board.*

*This evaluation board contain ESD sensitive parts.*

*Failure to follow these guidelines may result personal injury or death and/or equipment damage.*

*Vincotech GmbH is not responsible for any damage caused by use of this evaluation board.*

## 1 Objective

The objective of this paper is to help the user understand the board's main functionalities and provide instructions on how to get started and operate it effectively. This paper only covers the most important information. For a more detailed description, please check the application notes and technical papers on the Vincotech website or contact us directly.

## 2 The functional blocks of the Evaluation Board

The evaluation board consists of three distinct functional blocks:

- The current synthesizing PFC (CSPFC)
- The booster
- The output inverter

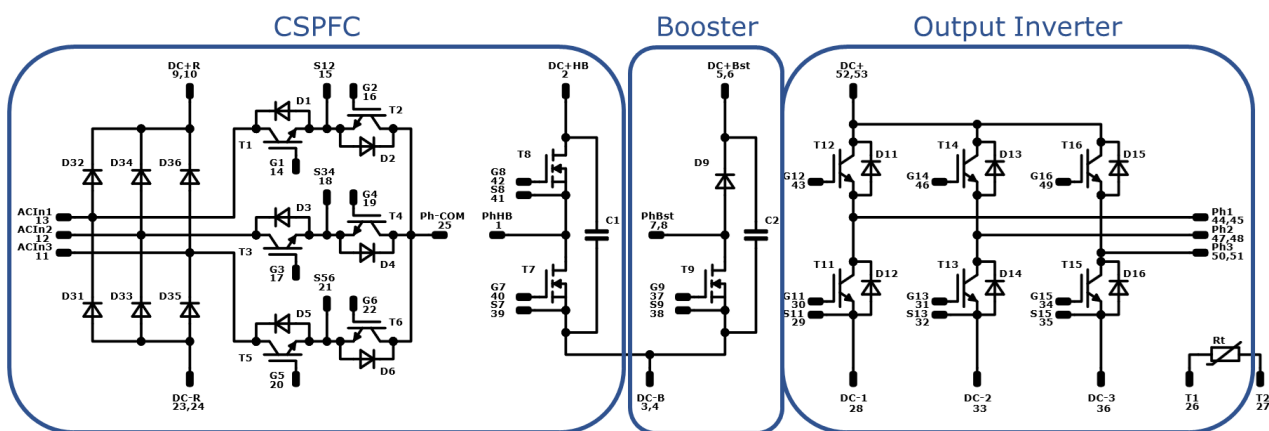

Figure 1: The schematic of the module and the functional blocks of the Evaluation Board

The CSPFC block requires constant output power for operation. The constant output power can be generated by the booster stage or the output inverter stage.

### 3 The power module

The evaluation board was designed for the Vincotech *flowPIM S3 + 3xPFC* 1200 V 40 A power module, B0-SL12PPA040SH-PC88L41Z-/7/. It contains the input rectifier, the MUX+HB circuit, the booster stage, and the output inverter. The schematic of the module is presented in Figure 2 and the outline drawing in Figure 3.

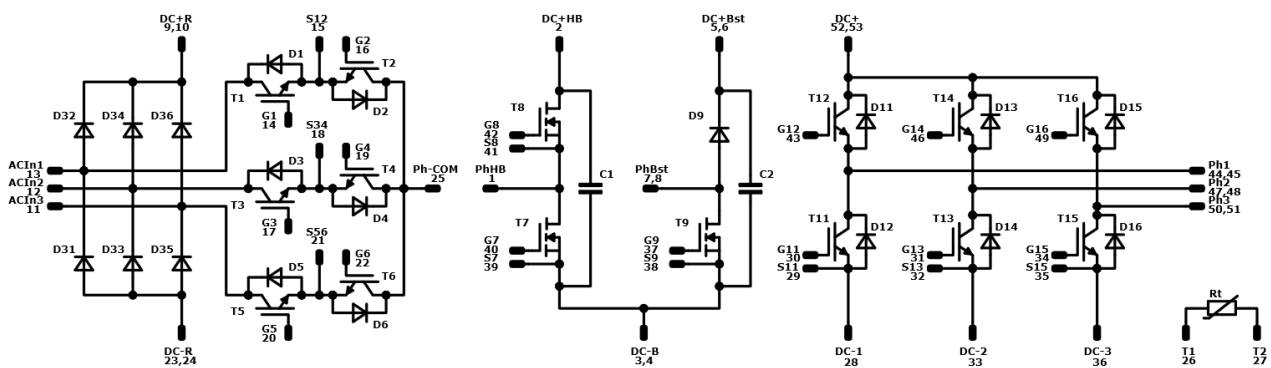

Figure 2: The schematic of the power module

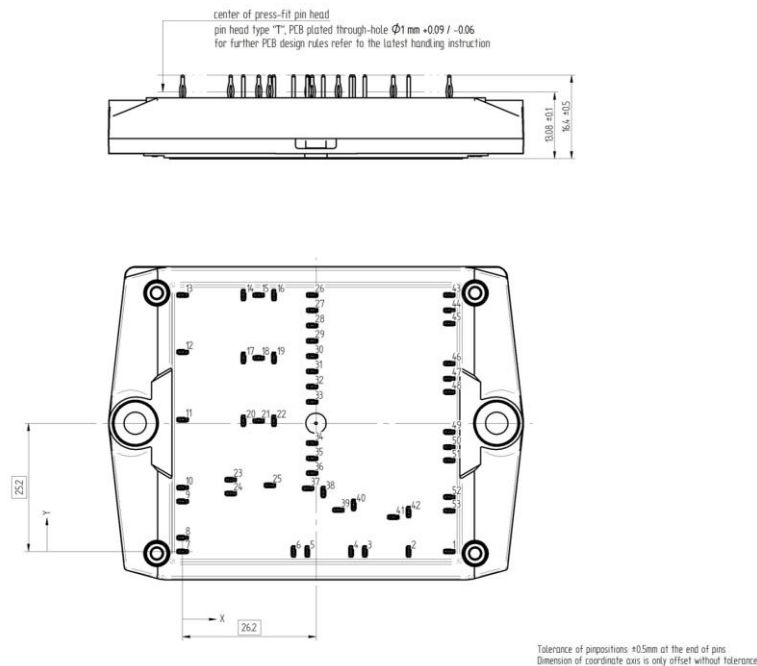

Figure 3: The pin-out of the module

For a more detailed description of the module, please visit the Vincotech web page.

## 4 Short introduction of the board

The main board comprises four distinct cards, listed here:

- The MUX GD card drives the MUX IGBTs, which are responsible for selecting the correct phase for the third harmonic current.
- The INV GD PS card contains an isolated power supply circuit for the output inverter gate drives.
- The Texas Instruments F28379D card is the control card and contains the MCU.
- The AUX PS card is the auxiliary power supply card and provides +12 V and +5 V for the logic circuits. This card is optional. An external DC supply can be used as an alternative power source.

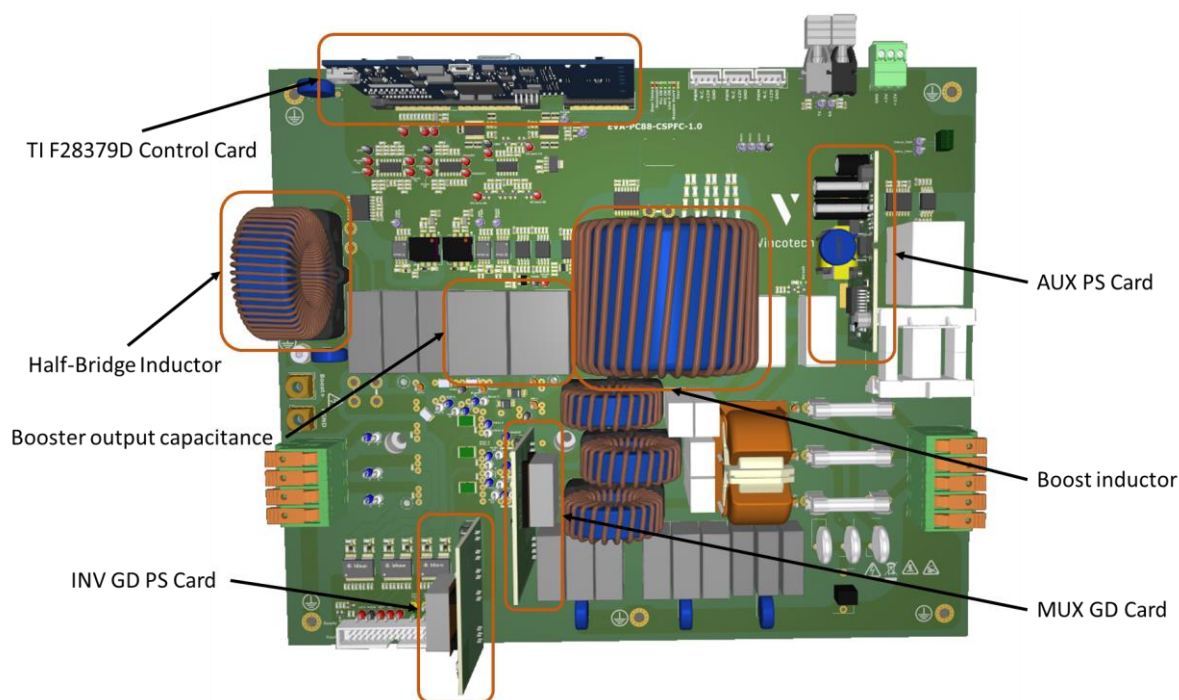

Figure 4: The parts of the evaluation board

The low voltage DC supply can be drawn from the grid using the AUX PS card or supplied by connecting an external DC supply. The evaluation board can, therefore, be ordered with two different part numbers:

- EVA-PC88L41Z-CSPFC-A-KIT without the AUX PS card
- EVA-PC88L41Z-CSPFC-B-KITwith the AUX PS card

The evaluation board contains test points to simplify signal measurement. The test points are color-coded based on their function as follows:

- White: Gate signals
- Blue: Emitter/source sense signal
- Yellow: High Voltage potentials
- Black: GND signals (e.g.: PGND and GND) These GND potentials are galvanically isolated from each other.
- Purple: Logical signals
- Red: Analog signals

## 5 Absolute maximum ratings

Symbol	Parameter	Conditions	Value			Unit
			Min	Typ	Max	
$V_{inRMS}$	AC RMS input phase voltage	$P_{max} = 11 \text{ kW}$	219	230	253	V
$V_{inRMS}$	AC RMS input phase voltage	$P_{max} = 10 \text{ kW}$	207	230	253	V
$f_{in}$	Input frequency		47	50	63	Hz
$P_{INmax}$	Maximum input power	$T_s = 80 \text{ }^\circ\text{C}$ ,	11			kW
$V_{DCboostmax}$	Maximum DC output voltage of the Booster		820			V
$I_{inRMS}$	Maximum RMS input current per phase	$T_s = 80 \text{ }^\circ\text{C}$ , sinusoidal current waveform	16			A

$I_{OutPeakINV}$	Maximum RMS output current of the output inverter	$T_s = 80\text{ °C}$ , sinusoidal current waveform	20	A
$I_{OutPeakBoost}$	Maximum peak output current of the booster	$T_s = 80\text{ °C}$ $V_{DCboost} = 700\text{ V}$	15.7	A
$I_{FANmax}$	Maximum output current of the FAN drive (per output)		400	mA
$I_{auxPSmax}$	Maximum output current of the AUX power supply card		1.5	A
$T_{PCBmax}$	Maximum PCB temperature		115	°C
$T_{OPmax}$	Maximum operation temperature		$T_{jmax} - 25\text{ °C}$	°C

## 6 Starting the evaluation board



**Before using the evaluation board, the module must be screwed to a heatsink! Failure to do so may result in elevated semiconductor temperatures, which can damage the module. Please use a heatsink capable of handling the associated losses.**



**All GND connections must be connected to the heatsink.**

For proper operation, all connections must be correctly established before powering up the board. The three-phase input connector must be connected to the three-phase grid in the correct order (PHA, PHB, PHC). If the correct sequence is not followed, the evaluation board



will not start. The regulator logic requires a sinusoidal input. Please ensure a sufficiently high-quality input voltage. The presence of significant harmonics may prevent the evaluation board from synchronizing and starting.

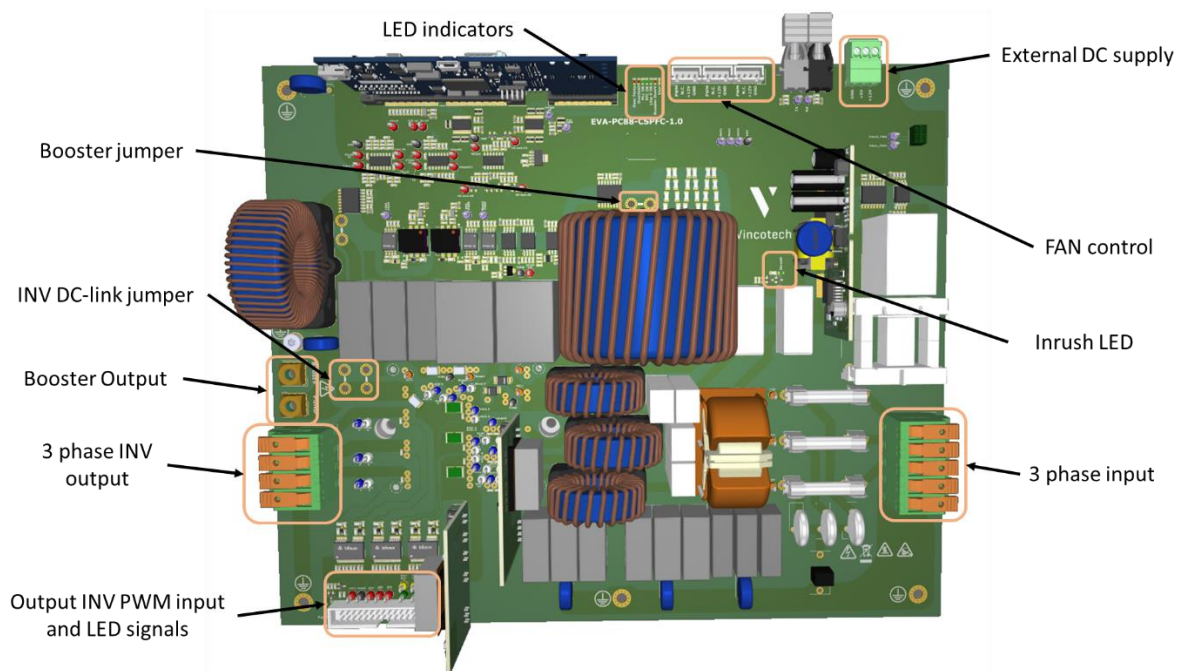

Figure 5: The connectors and the LED signals of the Board

The three stages should be connected in the right order based on the user needs. Please refer to Figure 5 for the connector and jumper locations.

1. When using the booster circuit for output and constant power generation for the CSPFC, the load must be connected to the booster output and the booster jumper must be closed. In this scenario, the output inverter is inactive and does not request any connection and drive signal.
2. When constant power is provided by the output inverter itself, the booster is not used. The load must be connected to the three-phase INV output connector, the booster jumper opened, and the INV DC-link jumper connected to REC+. In this case, external drive signals must be applied to the output inverter (see paragraph 6.1.)
3. When the booster is relied on to generate constant power and the three-phase output is generated by the output inverter, all the three stages are operational. The booster

jumper must be closed, the INV DC-link jumper connected to Boost+, and the three-phase output connected to the 3 phase INV output. In this case, external drive signals must be applied to the output inverter (see paragraph 6.1.).

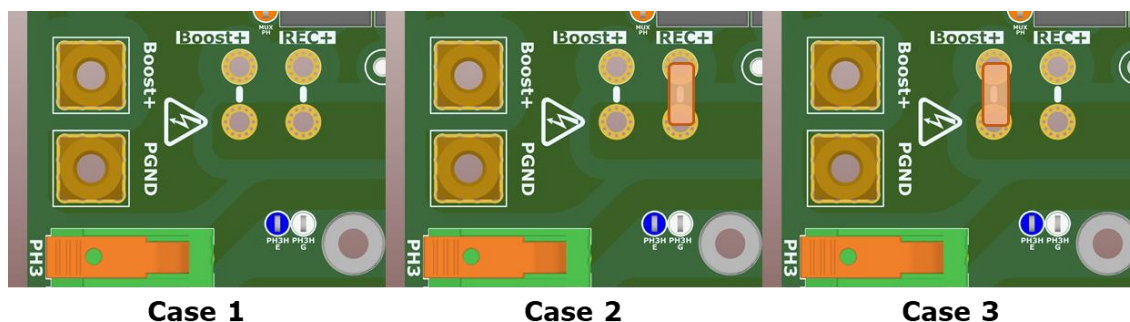

Figure 6: The INV DC-link jumper



**Caution: Once the grid is connected to the input, the rectifier stage will charge up the DC-link without driving the semiconductors! This can lead to electrical shock! For discharging, please refer to the safety information.**

When the input line voltage amplitude is within an acceptable range, the green Line V OK LED will light up. When the phase sequence is also OK and the PFC is synchronized to the grid, the green PLL OK LED will also light up.



**The evaluation board must always be powered up without a load to prevent damaging the inrush resistors! The load can be enabled when the inrush relay is closed and the inrush LED light up.**



**Caution: This board is only designed for unidirectional operation. When a motor is applied on the output for brake operation a brake chopper must be used!**

Thermal cooling can be improved using forced air cooling. To this end, the evaluation board includes a three-channel 12 V FAN driver with a 5 V PWM signal for speed control. The control circuit attempts to maintain the temperature of the heatsink at 80 °C. When the maximum

temperature (100 °C) is attained, the MCU’s PWM output is suspended. Even when the PWM control is suspended through the rectifier diodes, the power output can continue to operate, further increasing the temperature and potentially causing failure. Once the temperature returns to 90 °C, the PWM output restarts and the Evaluation Board resumes normal operation.







<b>Over Temp</b>		Over-temperature detected
<b>Overload</b>		Overload detected
<b>PLL OK</b>		Line sequence OK, PFC synchronized to the grid
<b>PFC OK</b>		Load detected, HB working
<b>Line V OK</b>		3-phase input voltage amplitude OK
<b>Booster OverV</b>		Over-voltage on the booster (>820 V)
<b>User</b>		Fast blinking – PWM OFF Slow blinking – PWN ON

Table 1: The LED indicators of the board

The evaluation board provides over-temperature, overload, and over-voltage sensing. In the event of failure, the evaluation board interrupts operation until operation conditions return to normal. After five successive failures, operation is permanently stopped. All voltage supplies must be disconnected to restart the board.

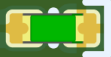
Figure 7 presents the correct starting sequence of the evaluation board.

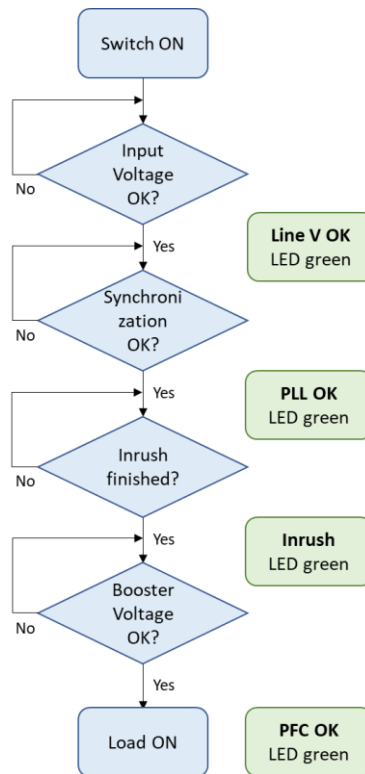

Figure 7: Starting sequence

## 6.1 Interface of the output inverter

The evaluation board includes the gate driver circuits and desaturation protection (Fault LED) for the output inverter but not the required control logic. The output inverter requires external drive signals to be provided using the output inverter PWM control connector. The detailed pin functions and names can be seen in Figure 8. LED indicators are used for the fault and ready signals. To power the control logic, an external +5 V DC supply should be connected to the LVCC pin. For a more detailed functional description of the output inverter, please refer to the 2ED020I12FAXUMA2 datasheet.

The output inverter's recommended maximum  $f_{sw}$  is 16 kHz. Exceeding that frequency may increase losses and damage the device.

Function	Name	Pin		Pin	Name	Function	
+5V	LVCC	1	■ ■	2	MDPH1H	PWM input for the gates	
	GND	3	■ ■	4	MDPH1L		
		5	■ ■	6	MDPH2H		
		7	■ ■	8	MDPH2L		
		9	■ ■	10	MDPH3H		
		11	■ ■	12	MDPH3L		
		13	■ ■	14	MDRDY		Ready
		15	■ ■	16	MDRST		Reset negative
		17	■ ■	18	MDFLT		Fault negative
		19	■ ■	20	GND		
Current Shunt negative side	IS- PH3	21	■ ■	22	IS+ PH3	Current Shunt positive side	
	GND	23	■ ■	24	GND		
	IS- PH2	25	■ ■	26	IS+ PH2		
	GND	27	■ ■	28	GND		
	IS- PH1	29	■ ■	30	IS+ PH1		

Figure 8: The Output Inverter Connector

## 7 Schematic of the evaluation board

### 7.1 Main board

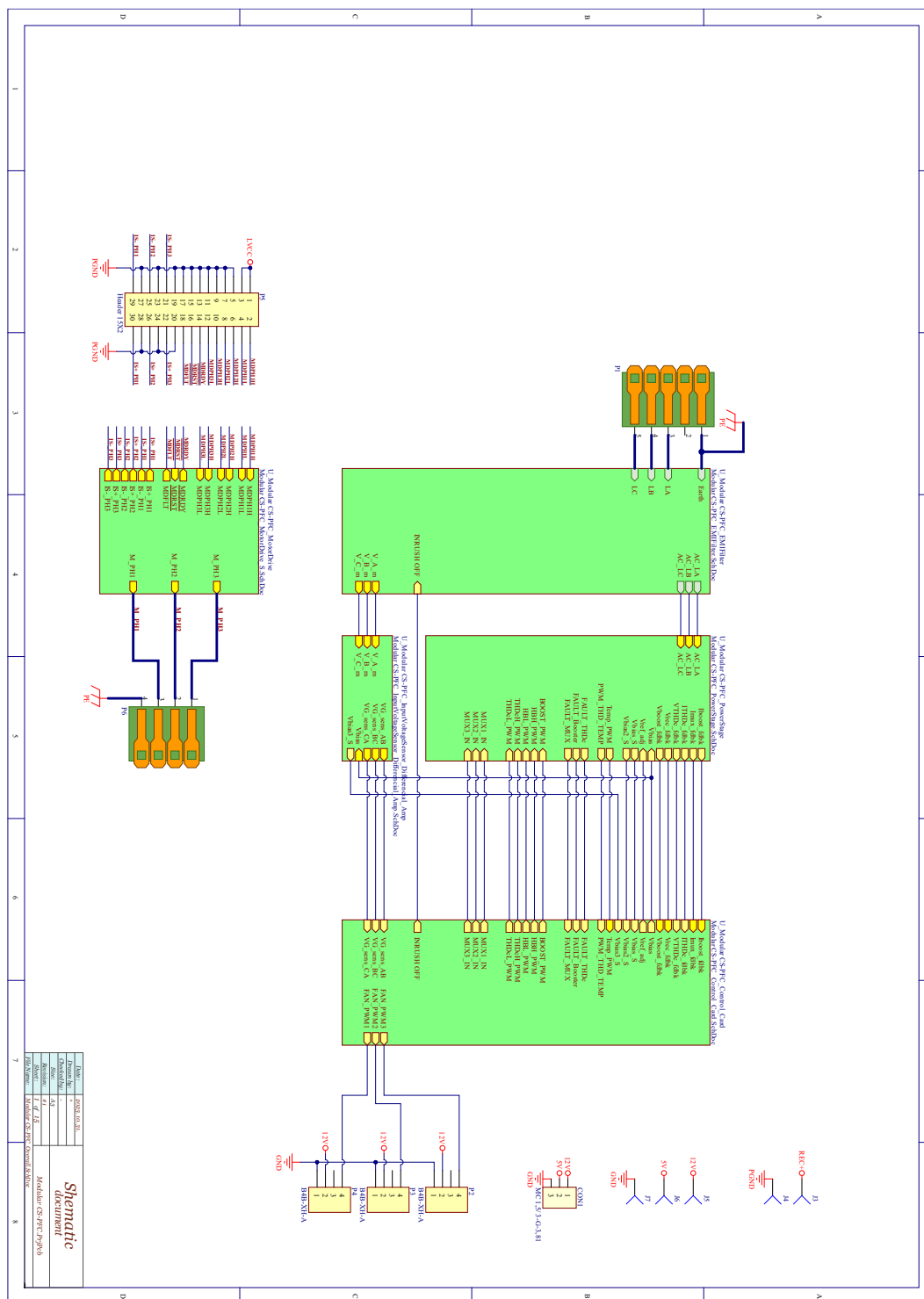

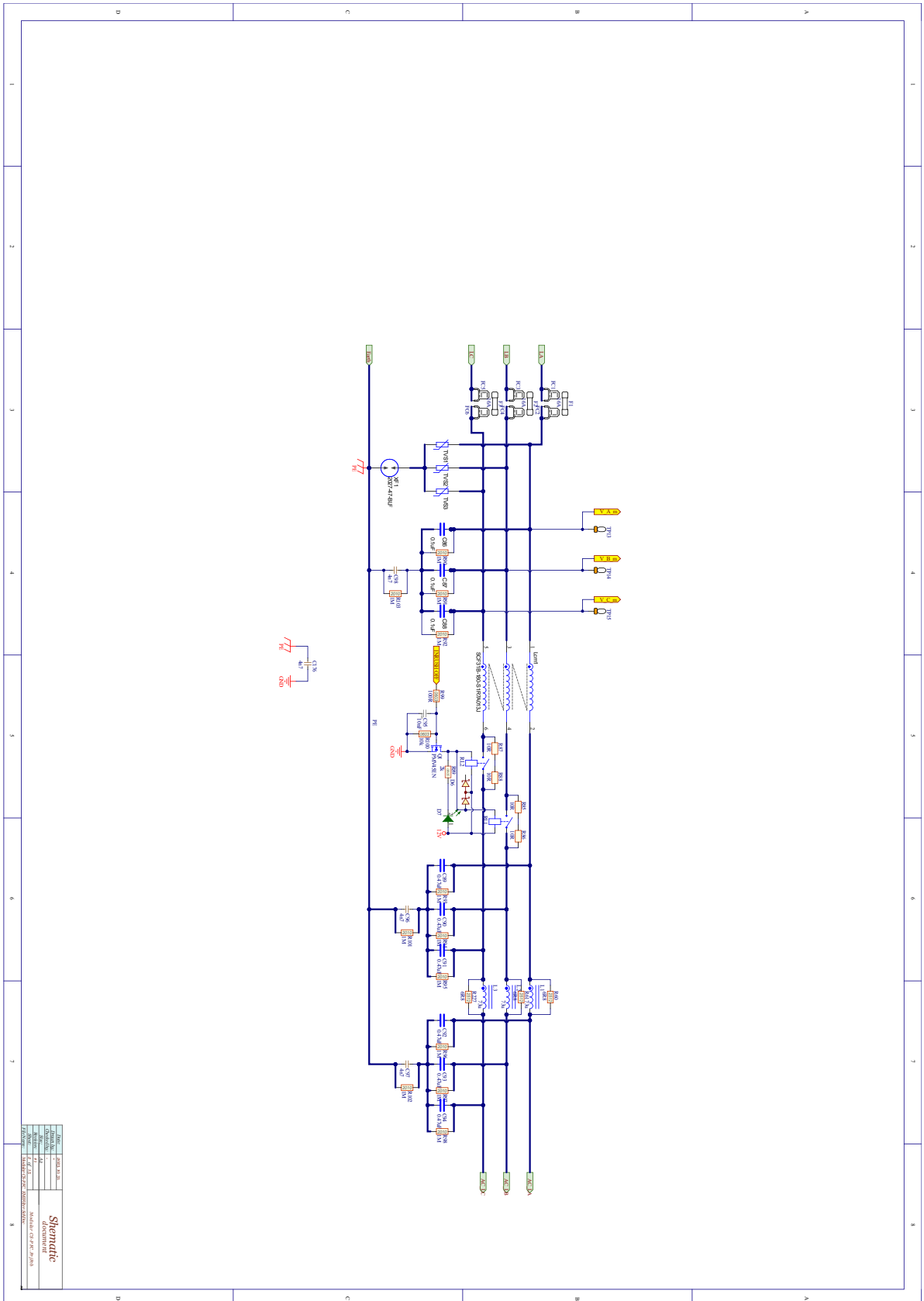

DATE	2024.03.14
DESIGNER	...
REVISION	...
APPROVED	...
PROJECT	...
DESCRIPTION	...
MANUFACTURER	...
REVISION	...

**Siematic**  
MAGAZIN-STRASSE 27-29  
42699 SOLINGEN

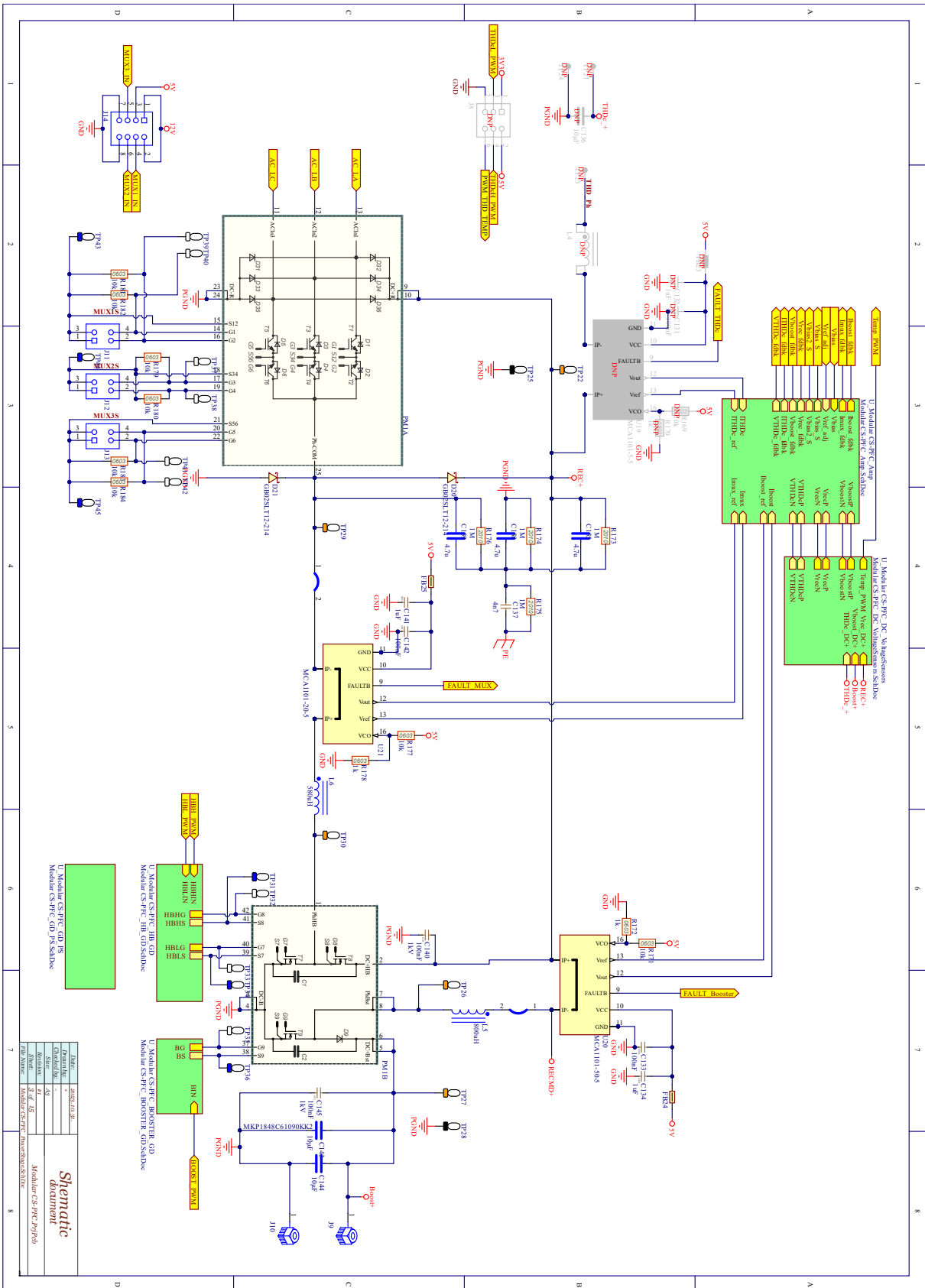

Part	Value
U1	Modular CS-PFC Amp
U2	Modular CS-PFC DC Voltage Controller
U3	Modular CS-PFC JIB GD
U4	Modular CS-PFC BOOSTER GD

Part	Value
U1	Modular CS-PFC Amp
U2	Modular CS-PFC DC Voltage Controller
U3	Modular CS-PFC JIB GD
U4	Modular CS-PFC BOOSTER GD

Part	Value
U1	Modular CS-PFC Amp
U2	Modular CS-PFC DC Voltage Controller
U3	Modular CS-PFC JIB GD
U4	Modular CS-PFC BOOSTER GD

Schematic  
d0400001



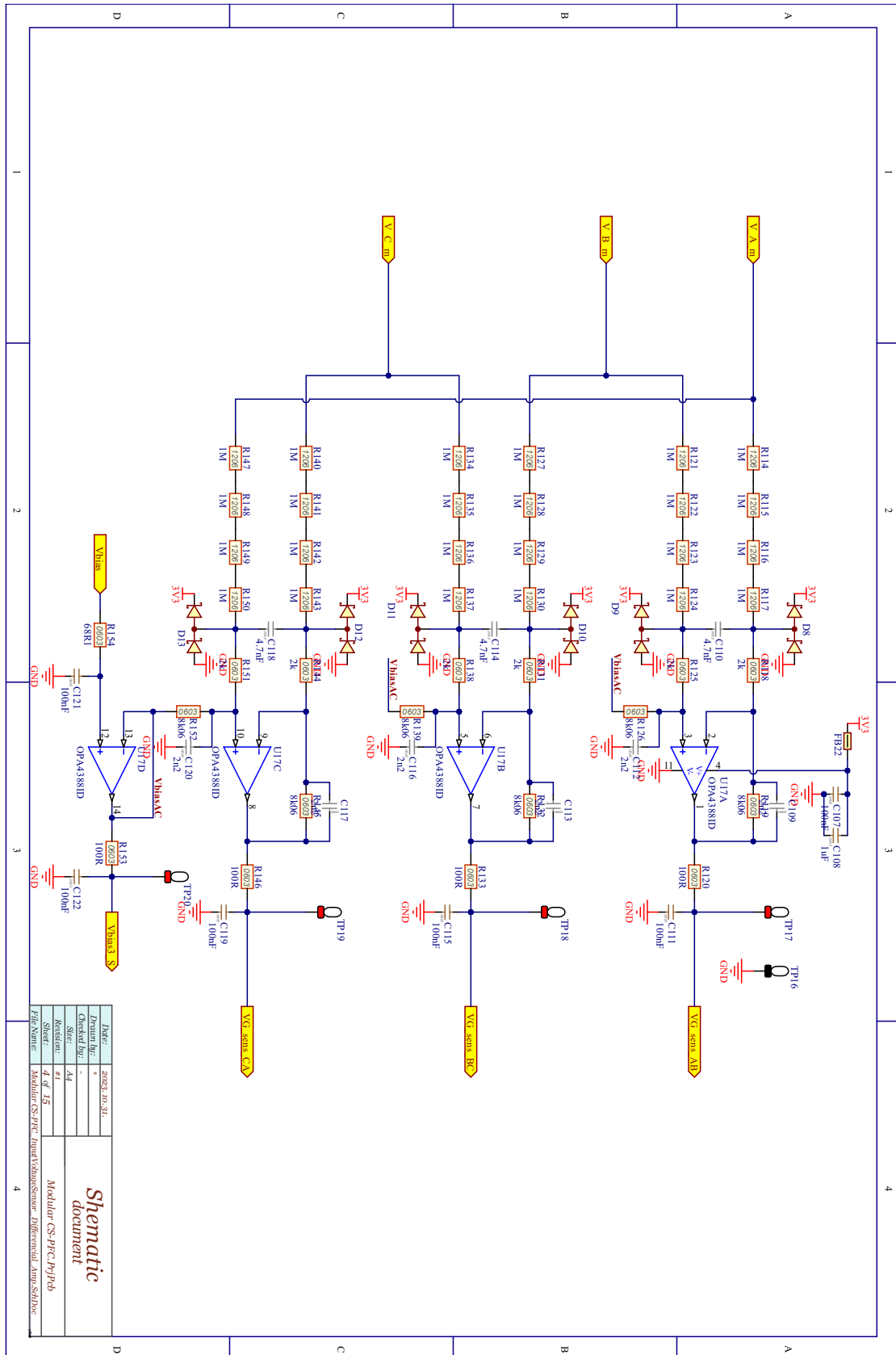

Date:	2023.10.31
Drawn by:	-
Checked by:	-
Sheet:	14
Revision:	1
Sheet:	4 of 15
File Name:	Module-CS-27C_InitialValueSense_Differential_Ann.SchLib

**Schematic document**

Module-CS-27C\_InitialValueSense\_Differential\_Ann.SchLib

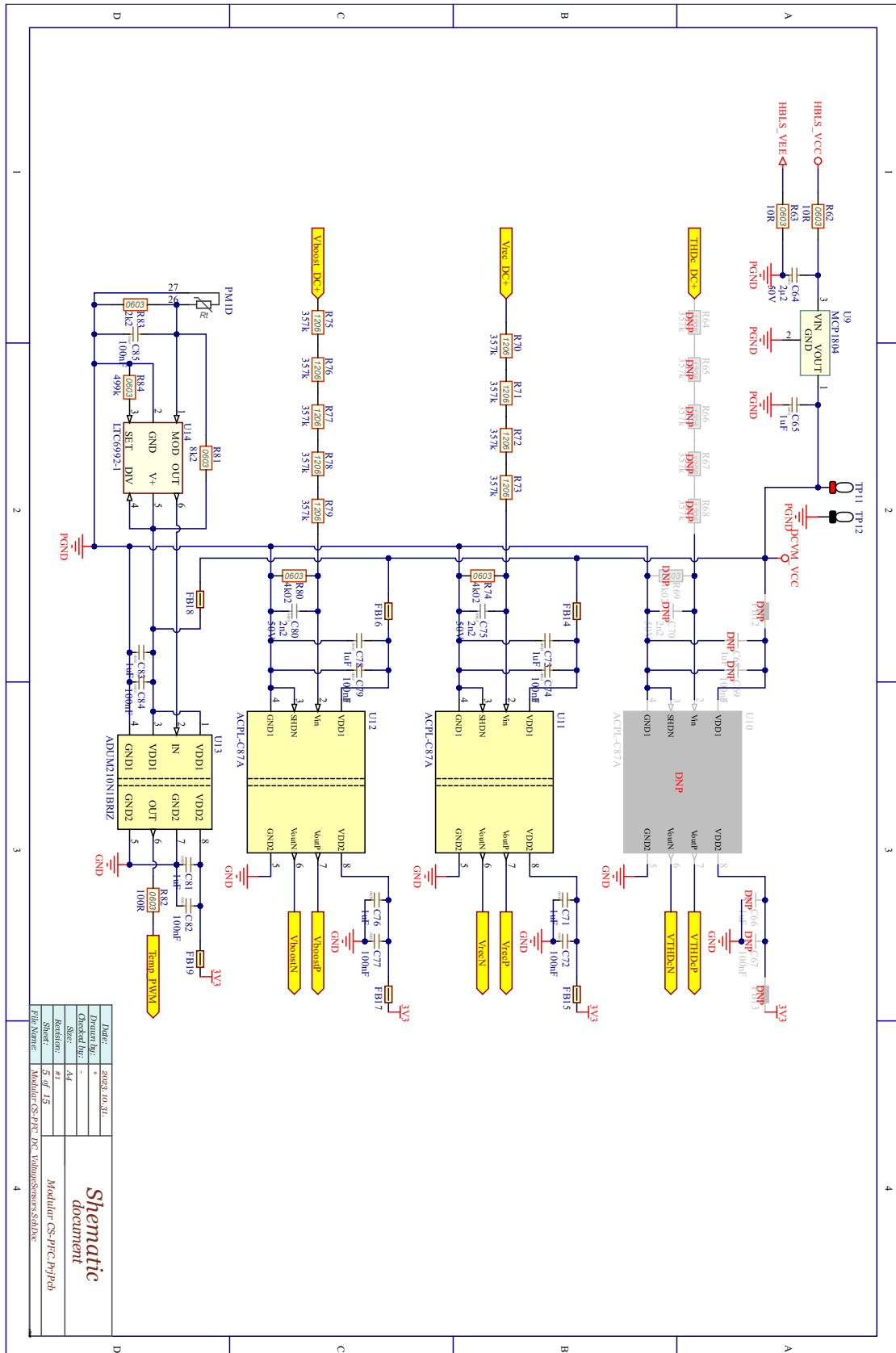

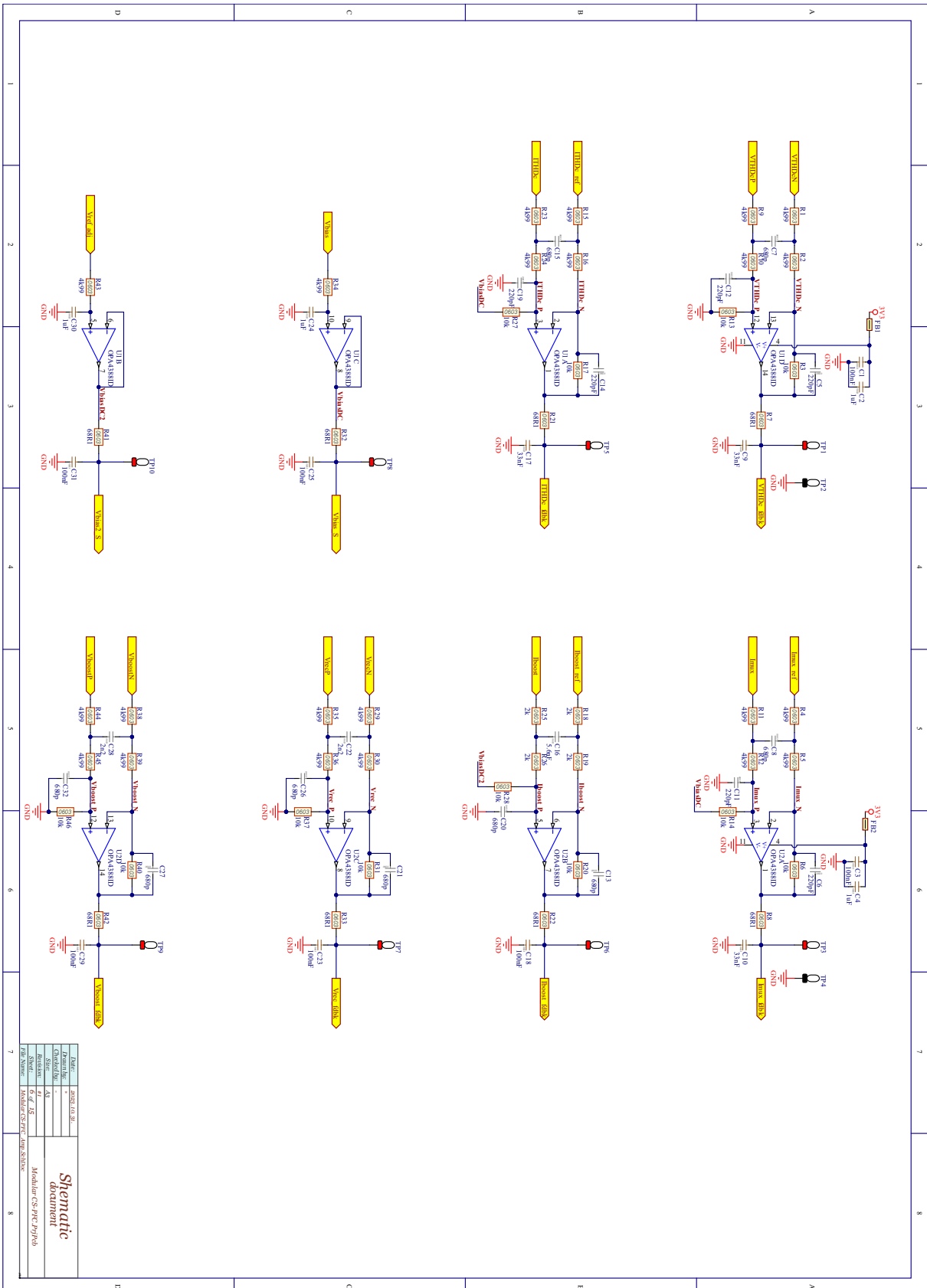

Item	Value
Date:	2024.03.30
Checked by:	-
Drawn by:	-
Scale:	1:1
Sheet:	4 of 12
Drawn:	-
File Name:	Module_CS_PFC_4muVpA.docx

**Schematic document**  
Module CS\_PFC\_4muVpA

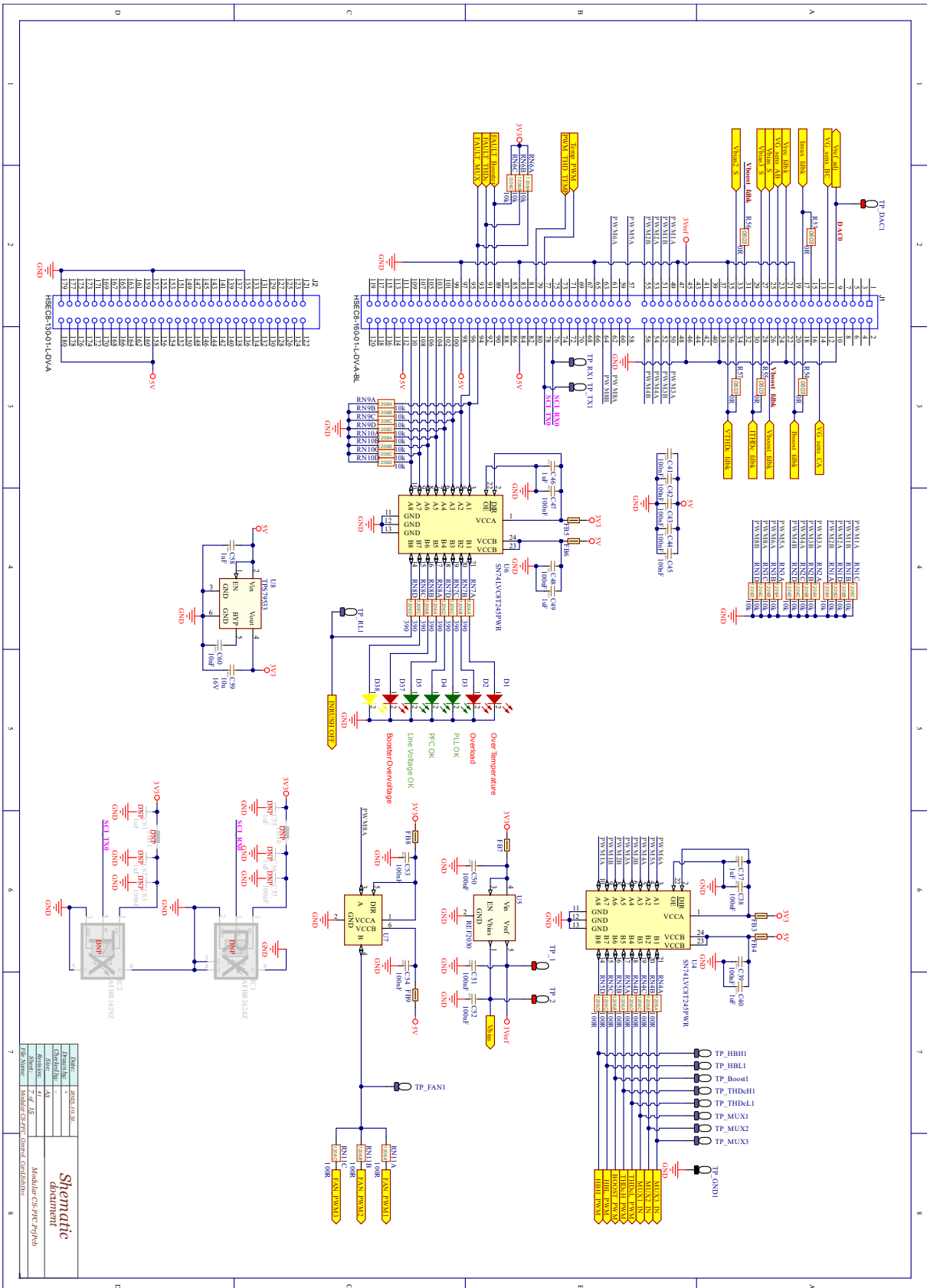

Part	Value
Checked by	
Size	4.0
Sheet	48
Rev	1.0
File Name	Modulair_S/PFC_Current_Sense/Modulair_S/PFC_Current_Sense_Schematic.dwg

**Schematic**  
document

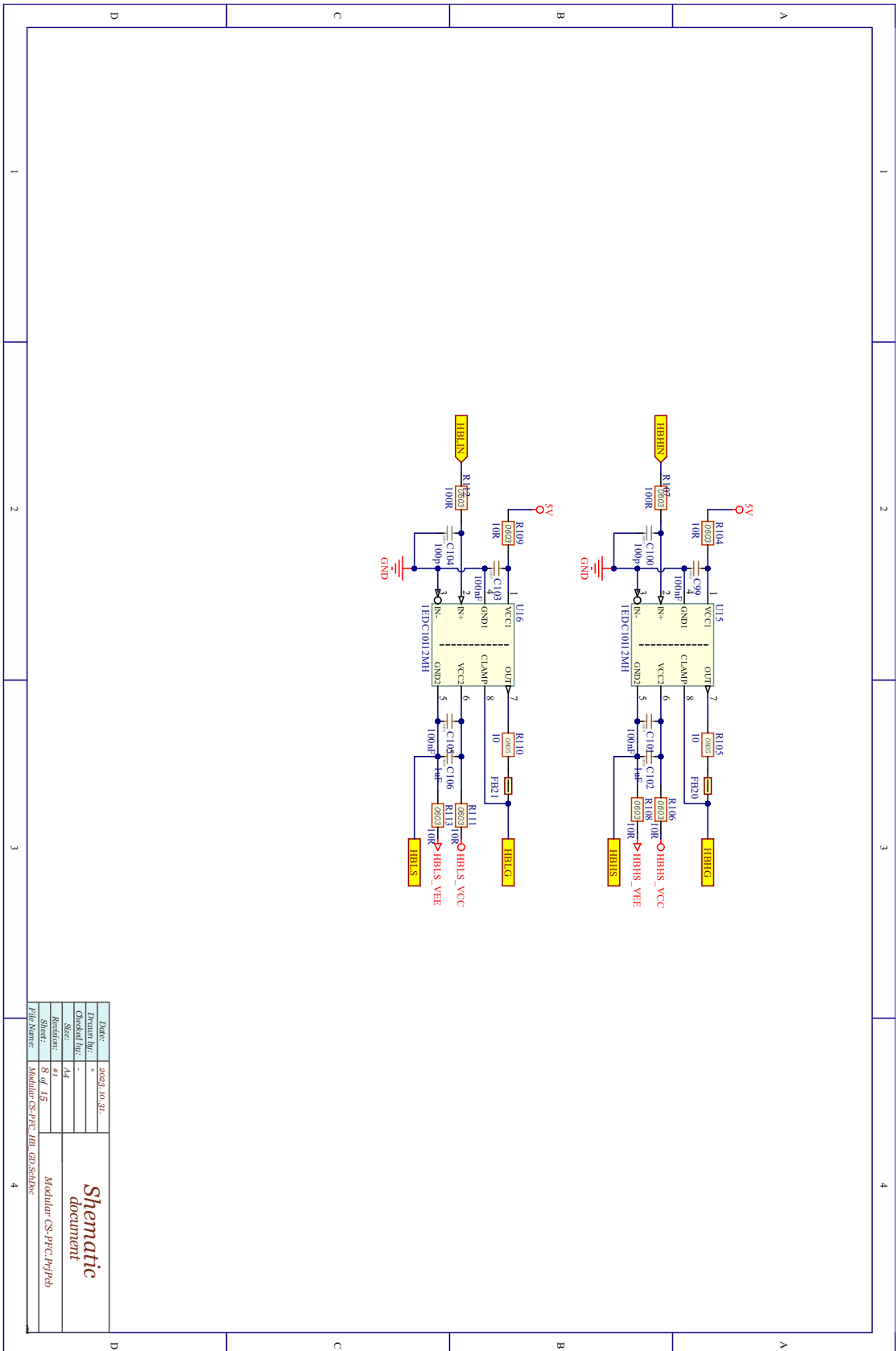

Date:	2023.10.31	<b>Schematic document</b> Modulator-CS-PFC-HP-GB-Schaltplan
Drawn by:	-	
Checked by:	-	
Sheet:	144	
Revision:	#1	
Sheet:	8 of 15	
File Name:	Modulator-CS-PFC-HP-GB-Schaltplan	

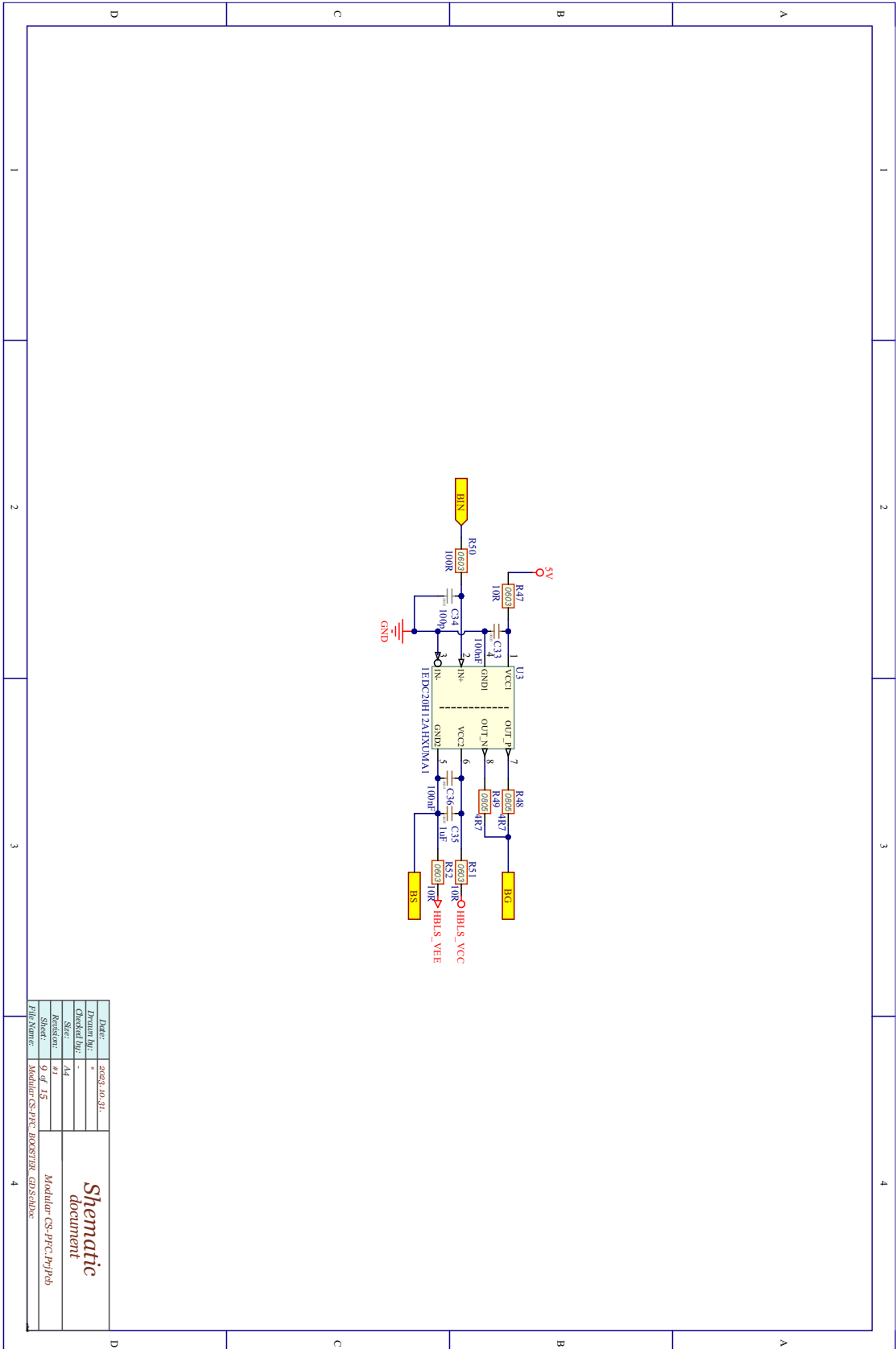

Date:	2023.10.21
Drawn By:	-
Checked By:	-
Sheet:	14
Revision:	01
Sheet:	9 of 15
File Name:	Module-CS-PRC_IGBT/PRC_G12SH100

**Schematic  
document**

Module-CS-PRC\_IGBT/PRC\_G12SH100

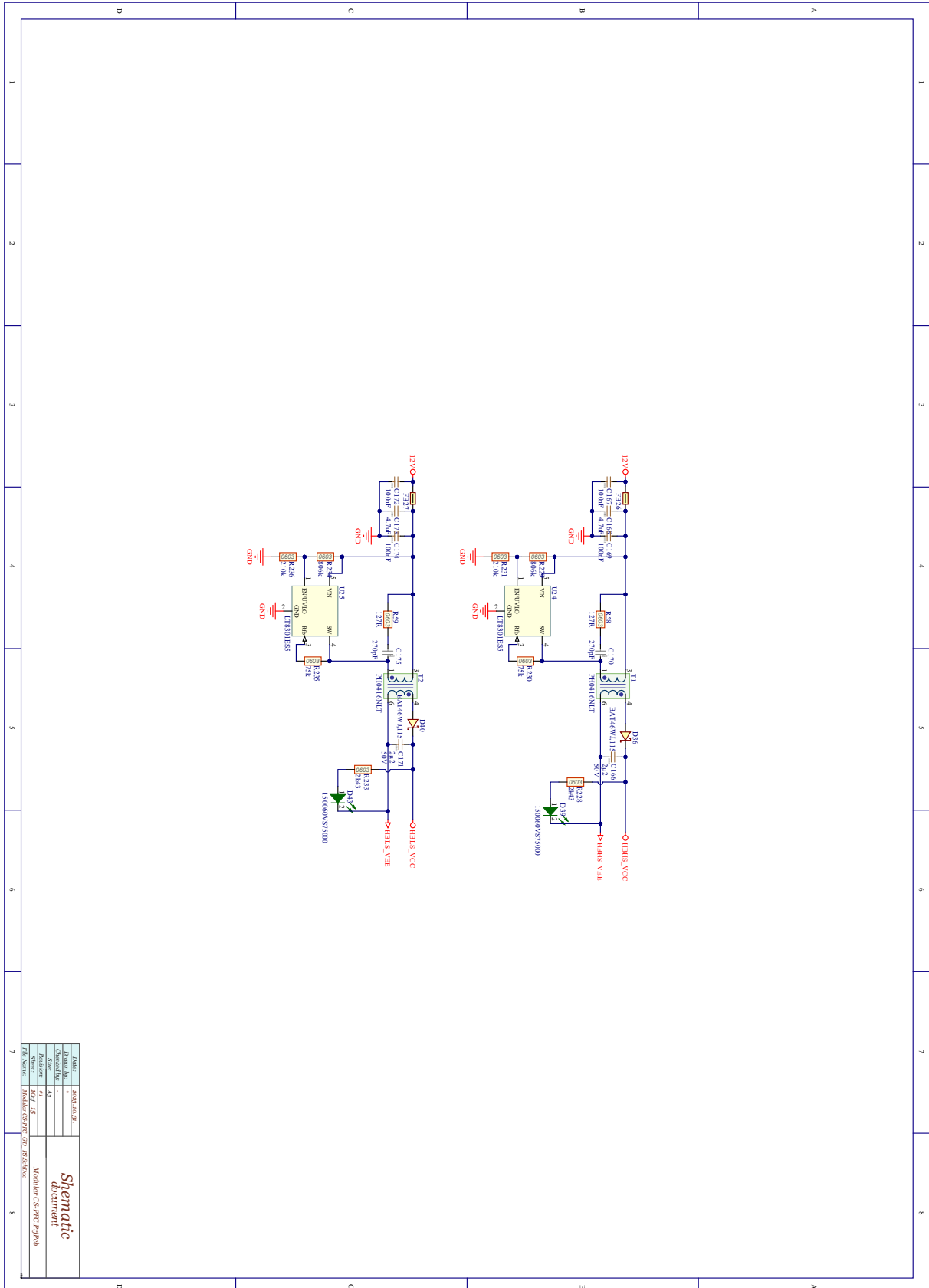

Date:	2024.04.30
Checked by:	-
Drawn by:	AM
Sheet:	1
Total sheets:	1
File Name:	Modular S/PFC D2A mRS30v6

**Schematic**

document

Modular S/PFC D2A mRS30v6

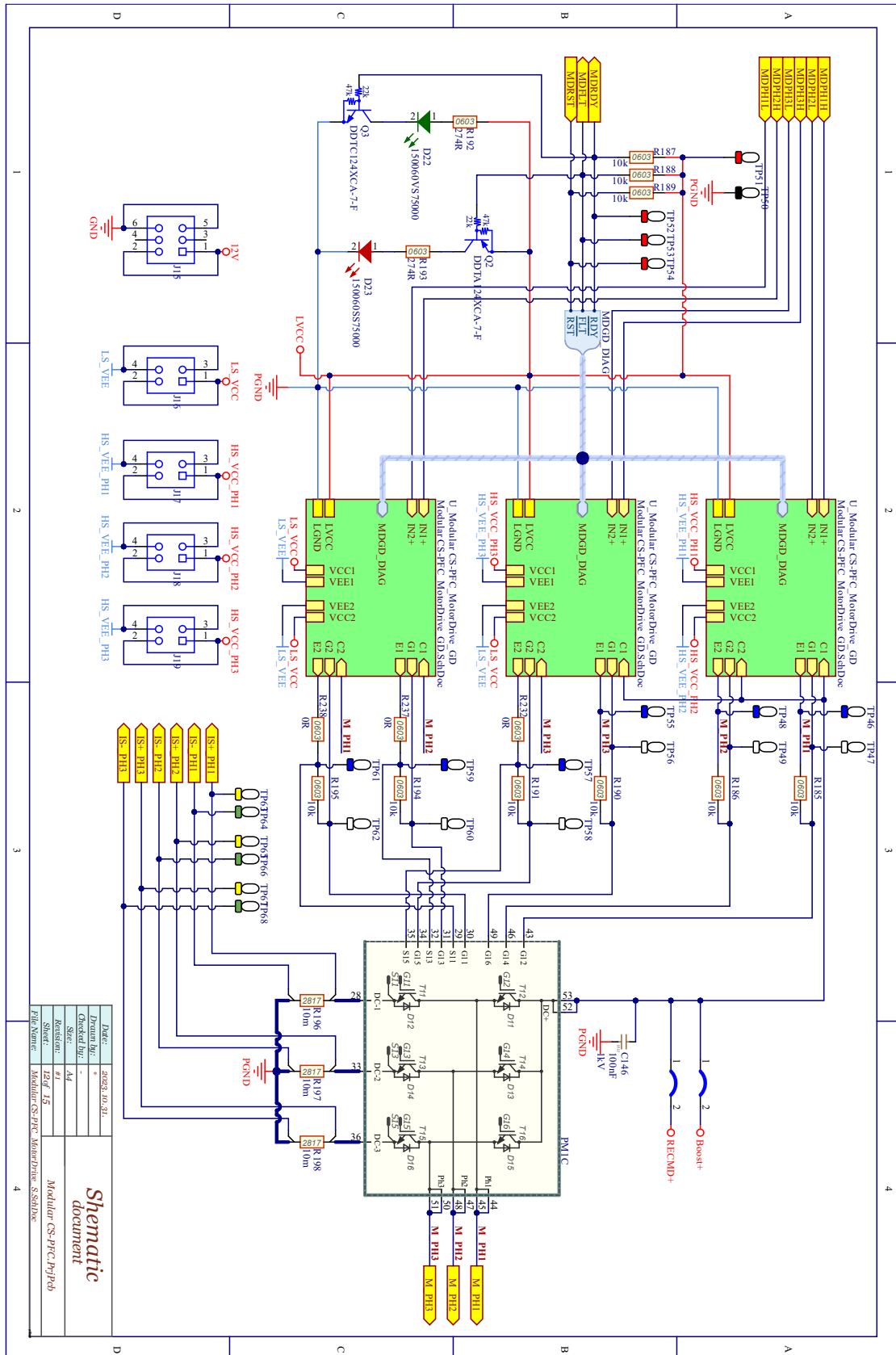

Date:	2023.10.21
Drawn by:	-
Checked by:	-
Sheet:	44
Revision:	#1
Sheet:	12 of 15
File Name:	Modular-CS-TPIC_MotorDrive_S.SchDoc

**Schematic document**

Modular-CS-TPIC\_PhPh



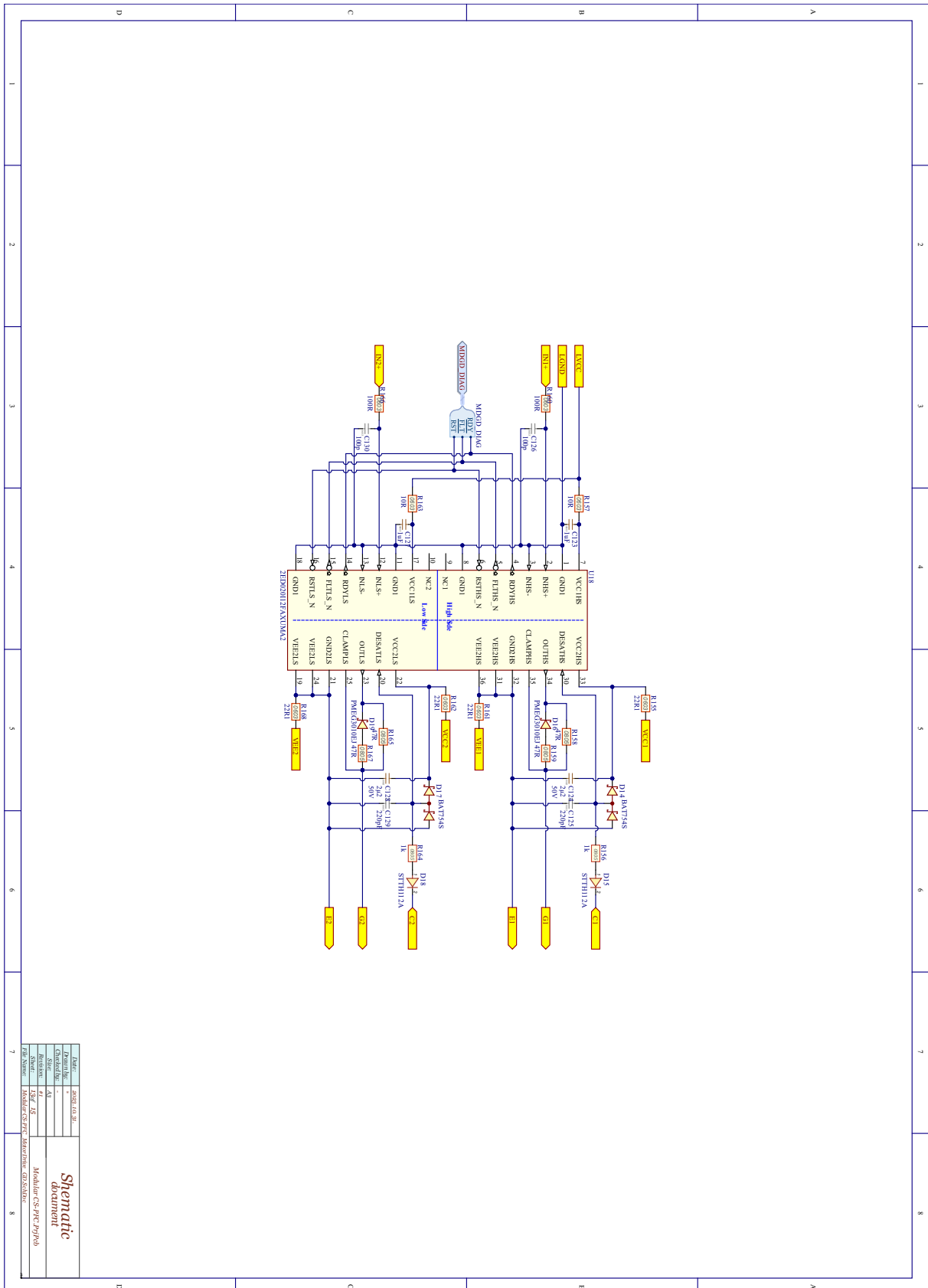

Rev:	2024.04.30
Checked by:	-
Size:	A4
Sheet:	1 of 1
File Name:	Modular_CS_PFC_Motorize_on_Slave

**Schematic**  
**document**

Modular CS PFC Motorize

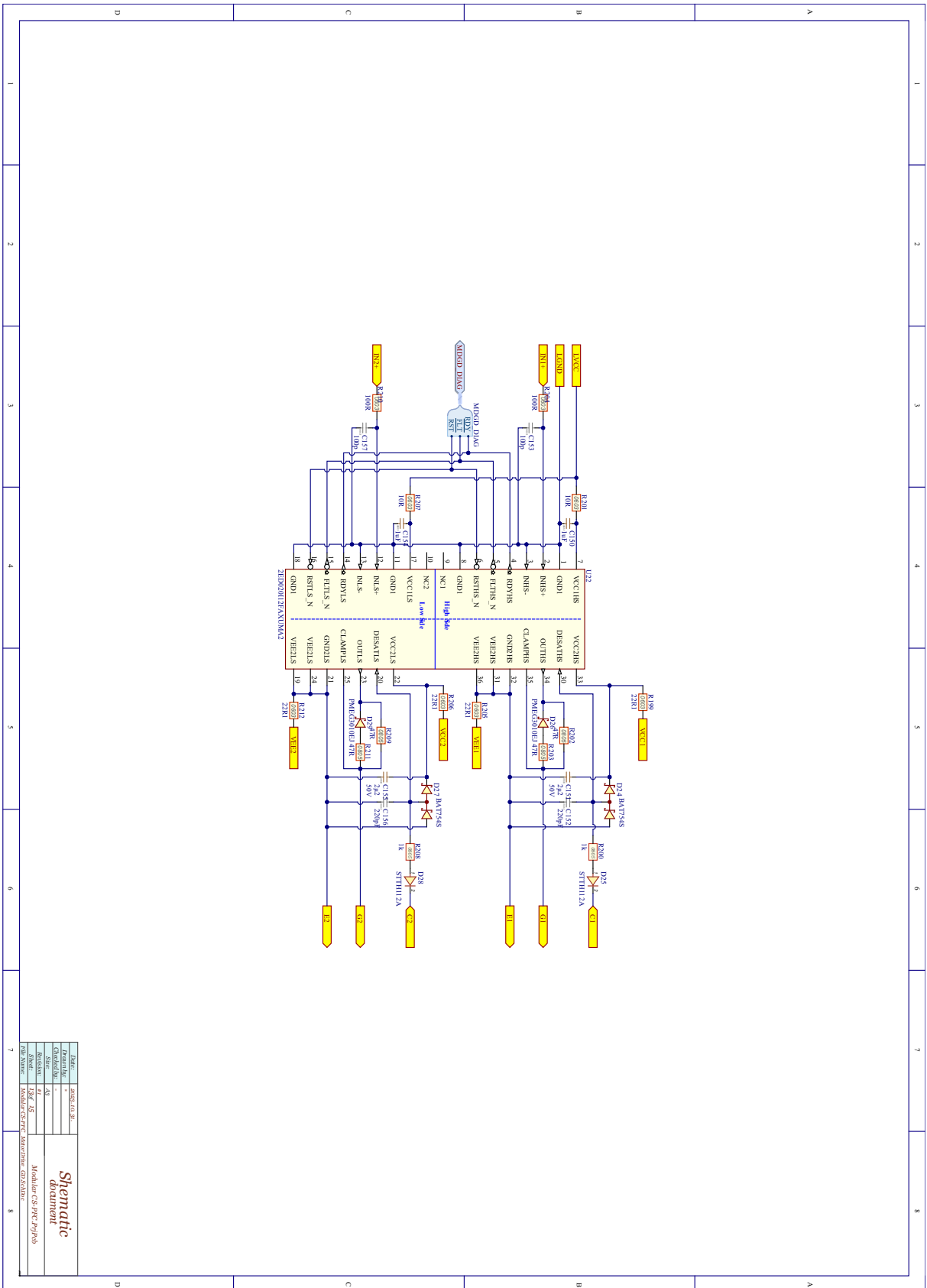

Doc No.	2008_04_01
Checked By	
Size	A4
Date	18/01/08
File Name	Modulair CS PFC 2008_04_01

**Schematic**  
document

Modulair CS PFC 2008\_04\_01

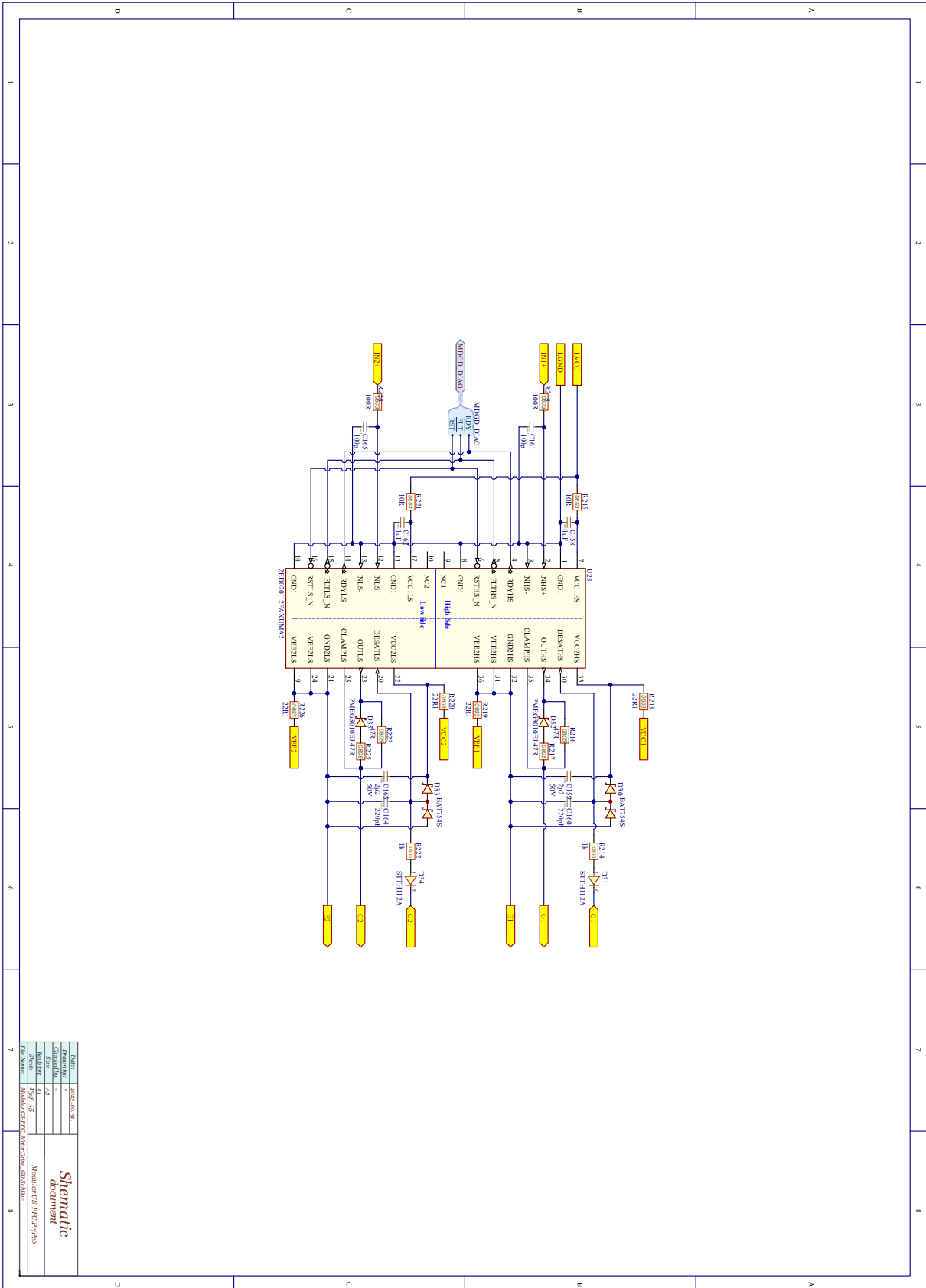



### 7.2 AUX PS card

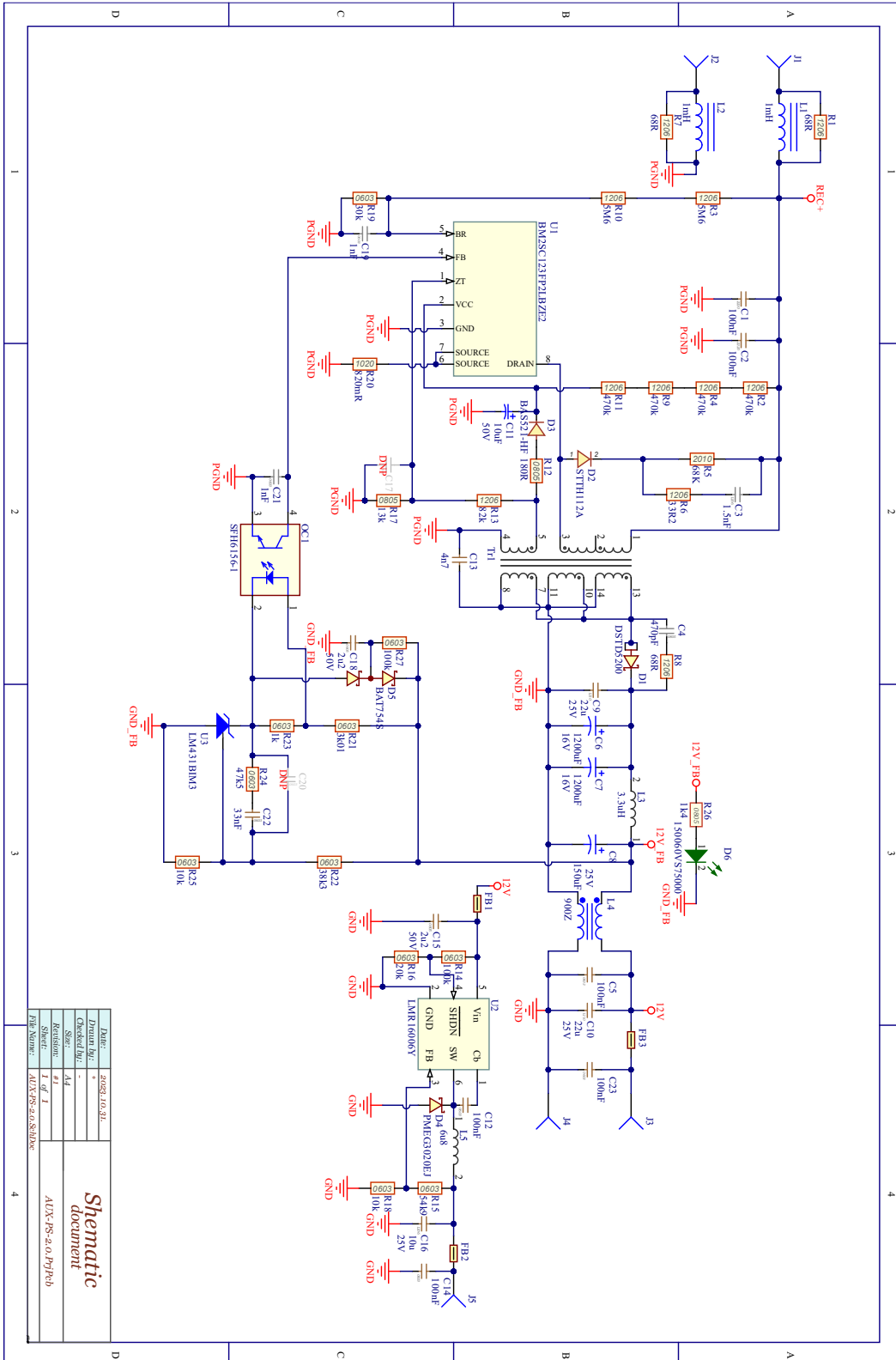



### 7.3 MUX GD card

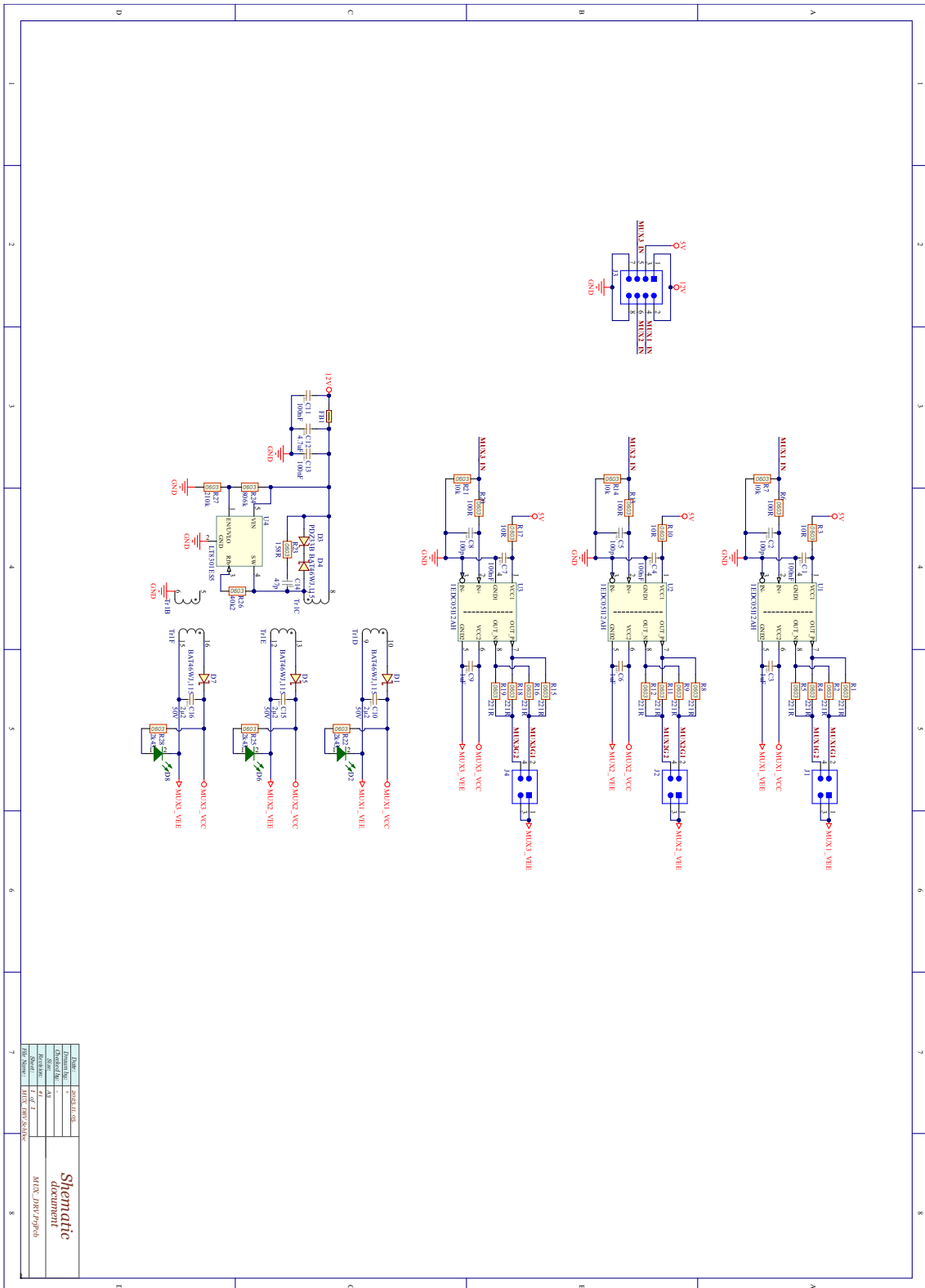

Item:	2024.01.06
Author:	
Checked:	
Rev. 1 of 1	
Rev. 2 of 1	
Rev. 3 of 1	
Rev. 4 of 1	
Rev. 5 of 1	
Rev. 6 of 1	
Rev. 7 of 1	
Rev. 8 of 1	
Rev. 9 of 1	
Rev. 10 of 1	
Rev. 11 of 1	
Rev. 12 of 1	
Rev. 13 of 1	
Rev. 14 of 1	
Rev. 15 of 1	
Rev. 16 of 1	
Rev. 17 of 1	
Rev. 18 of 1	
Rev. 19 of 1	
Rev. 20 of 1	
Rev. 21 of 1	
Rev. 22 of 1	
Rev. 23 of 1	
Rev. 24 of 1	
Rev. 25 of 1	
Rev. 26 of 1	
Rev. 27 of 1	
Rev. 28 of 1	
Rev. 29 of 1	
Rev. 30 of 1	
Rev. 31 of 1	
Rev. 32 of 1	
Rev. 33 of 1	
Rev. 34 of 1	
Rev. 35 of 1	
Rev. 36 of 1	
Rev. 37 of 1	
Rev. 38 of 1	
Rev. 39 of 1	
Rev. 40 of 1	
Rev. 41 of 1	
Rev. 42 of 1	
Rev. 43 of 1	
Rev. 44 of 1	
Rev. 45 of 1	
Rev. 46 of 1	
Rev. 47 of 1	
Rev. 48 of 1	
Rev. 49 of 1	
Rev. 50 of 1	
Rev. 51 of 1	
Rev. 52 of 1	
Rev. 53 of 1	
Rev. 54 of 1	
Rev. 55 of 1	
Rev. 56 of 1	
Rev. 57 of 1	
Rev. 58 of 1	
Rev. 59 of 1	
Rev. 60 of 1	
Rev. 61 of 1	
Rev. 62 of 1	
Rev. 63 of 1	
Rev. 64 of 1	
Rev. 65 of 1	
Rev. 66 of 1	
Rev. 67 of 1	
Rev. 68 of 1	
Rev. 69 of 1	
Rev. 70 of 1	
Rev. 71 of 1	
Rev. 72 of 1	
Rev. 73 of 1	
Rev. 74 of 1	
Rev. 75 of 1	
Rev. 76 of 1	
Rev. 77 of 1	
Rev. 78 of 1	
Rev. 79 of 1	
Rev. 80 of 1	
Rev. 81 of 1	
Rev. 82 of 1	
Rev. 83 of 1	
Rev. 84 of 1	
Rev. 85 of 1	
Rev. 86 of 1	
Rev. 87 of 1	
Rev. 88 of 1	
Rev. 89 of 1	
Rev. 90 of 1	
Rev. 91 of 1	
Rev. 92 of 1	
Rev. 93 of 1	
Rev. 94 of 1	
Rev. 95 of 1	
Rev. 96 of 1	
Rev. 97 of 1	
Rev. 98 of 1	
Rev. 99 of 1	
Rev. 100 of 1	

Schematic document  
MUX\_GD\_REV01\_06



### 7.4 INV GD PS card

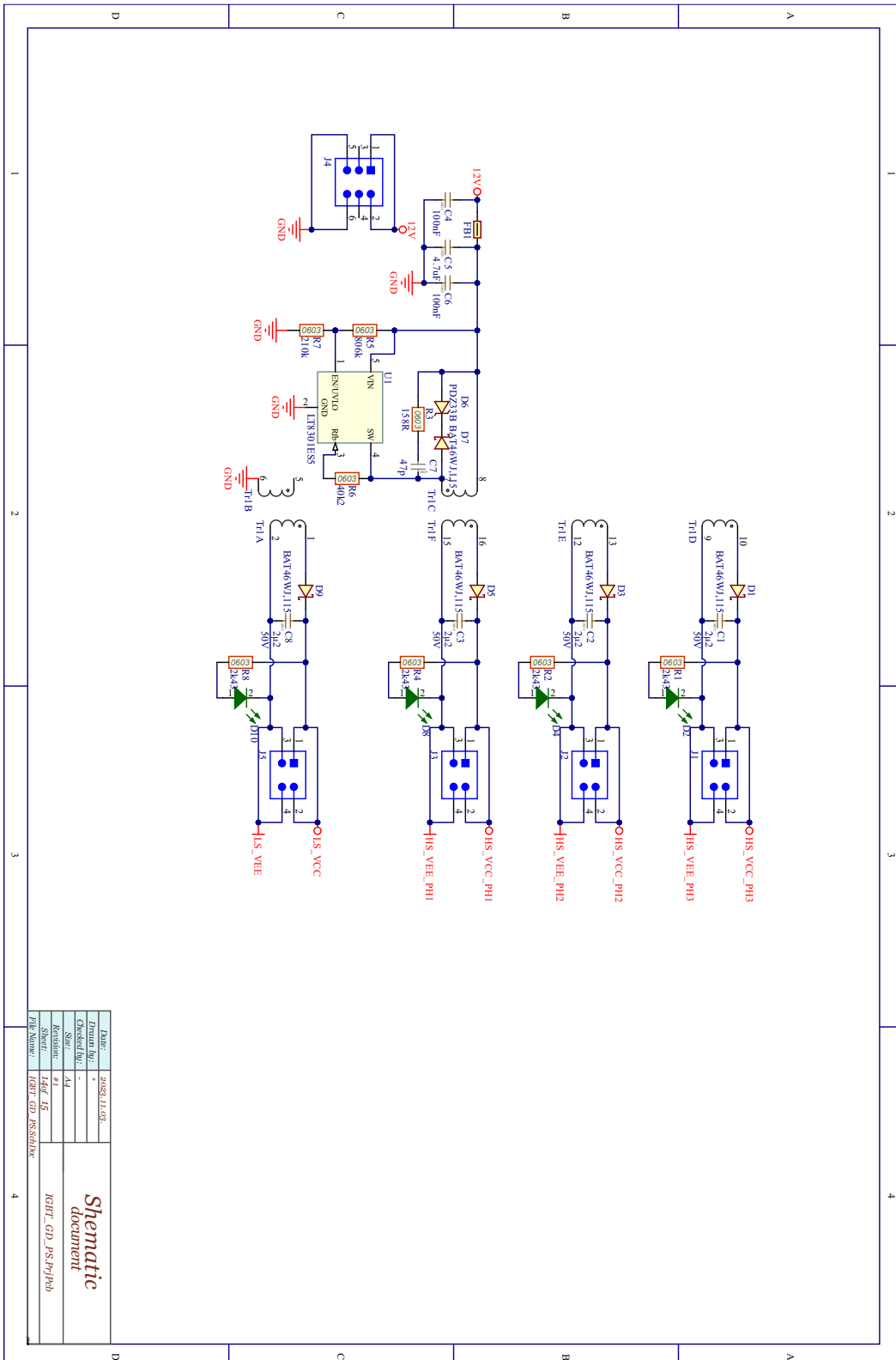

Part:	2023.11.03
Drawn by:	*
Checked by:	-
Size:	A4
Revision:	1.0
File Name:	IGBT_GD_PS.SchDoc

**Schematic document**

IGBT\_GD\_PS.PjPcb



## 8 BOM

### 8.1 Main card

Nr.	Designator	Qty.	Manufacturer	Type
1	C1, C3, C18, C23, C25, C29, C31, C33, C36, C38, C39, C41, C42, C43, C44, C45, C47, C48, C50, C51, C52, C53, C54, C72, C74, C77, C79, C82, C84, C85, C99, C101, C103, C105, C107, C111, C115, C119, C121, C122, C133, C142, C167, C169, C172, C174	46	Murata	G CJ188R71H104KA12D
2	C2, C4, C24, C30, C37, C40, C46, C49, C58, C65, C71, C73, C76, C78, C81, C83, C108, C123, C127, C134, C141, C150, C154, C158, C162	25	Murata	GRM188C81E105KAADD
3	C5, C6, C11, C12, C14, C19, C125, C129, C152, C156, C160, C164	12	Murata	GRM1885C1H221JA01D
4	C7, C8, C13, C15, C20, C21, C26, C27, C32	9	TDK	CGA3E2C0G1H681J080A A
5	C9, C10, C17	3	Murata	G CJ188R71H333KA12D
6	C16	1	Murata	G CM1885C1H562JA16D
7	C22, C28, C75, C80, C109, C112, C113, C116, C117, C120	10	Murata	GRM1885C1H222JA01D
8	C34, C100, C104, C126, C130, C153, C157, C161, C165	9	KEMET	C0603C101J1GAC
9	C35, C102, C106	3	Murata	G CM21BR71H105MA03L
10	C59	1	Murata	GRM21BC71C106KE11L
11	C60, C95	2	Murata	GRM1885C1H103JA01D
12	C64, C124, C128, C151, C155, C159, C163, C166, C171	9	TDK	C2012X7R1H225K125AE
13	C86, C87, C88	3	KEMET	R413N310040M1M
14	C89, C90, C91, C92, C93, C94	6	KEMET	R49AN34700001M
15	C96, C97, C98, C137, C176	5	KEMET	C971U472MVWDBA7317
16	C110, C114, C118	3	Murata	G CM1885C1H472JA16J
17	C135, C138, C139	3	KEMET	R71PR447050H6K
18	C140, C145, C146	3	KEMET	C1812W104KDRACTU
19	C143, C144	2	KEMET	C4AQOBU5100M12J
20	C147, C148, C149	3	Murata	GRM188R72A223KAC4D
21	C168, C173	2	TDK	C2012X6S1H475K125AC



22	C170, C175	2	Murata	GCM1885C2A271JA16D
23	CON1	1	Phoenix Contact	1803280
24	D1, D2, D23, D37	4	Würth Electronics	150060SS75000
25	D3, D4, D5, D7, D22, D39, D43	7	Würth Electronics	150060VS75000
26	D6, D8, D9, D10, D11, D12, D13	7	Vishay Semiconductors	BAS70-04-E3-18
27	D14, D17, D24, D27, D30, D33	6	Nexperia	BAT754S,215
28	D15, D18, D25, D28, D31, D34	6	STMicroelectronics	STTH112A
29	D16, D19, D26, D29, D32, D35	6	Nexperia	PMEG3010EJ,115
30	D20, D21	2	Genesic	GB02SLT12-214
31	D36, D40	2	Nexperia	BAT46WJ,115
32	D38	1	Würth Electronics	150060YS75000
33	F1, F2, F3	3	Bel	0ADEC9160-BE
34	FB1, FB2, FB3, FB4, FB5, FB6, FB7, FB8, FB9, FB14, FB15, FB16, FB17, FB18, FB19, FB22, FB24, FB25, FB26, FB27	20	Murata	BLM18KG260TH1D
35	FB20, FB21	2	Würth Electronics	782853121
36	FC1, FC2, FC3, FC4, FC5, FC6	6	Littelfuse	01240061H
37	J1	1	Samtec	HSEC8-160-01-L-DV-A-BL
38	J2	1	Samtec	HSEC8-130-01-L-DV-A
39	J9, J10	2	Würth Electronics	7460408
40	J11, J12, J13, J16, J17, J18, J19	7	TE Connectivity	215309-2
41	J14	1	TE Connectivity	215309-4
42	J15	1	TE Connectivity	215309-3
43	Lcm1	1	KEMET	SCF31B-180-S1R7A013J
44	P1	1	Phoenix Contact	1098170
45	P2, P3, P4	3	JST	B4B-XH-A(LF)(SN)
46	P5	1	Molex	0878343019
47	P6	1	Phoenix Contact	1098169
48	Q1	1	Nexperia	PMV45EN2R





49	Q2	1	Diodes	DDTA124XCA-7-F
50	Q3	1	Diodes	DDTC124XCA-7-F
51	R1, R2, R4, R5, R9, R10, R11, R12, R15, R16, R23, R24, R29, R30, R34, R35, R36, R38, R39, R43, R44, R45	22	KOA Speer	RN731JTDD4991B25
52	R3, R6, R13, R14, R17, R20, R27, R28, R31, R37, R40, R46	12	Yageo	RT0603BRD1010KL
53	R7, R8, R21, R22, R32, R33, R41, R42, R154	9	Yageo	RC0603FR-1368R1L
54	R18, R19, R25, R26	4	Yageo	RT0603BRD072KL
55	R47, R51, R52, R62, R63, R104, R106, R108, R109, R111, R113, R157, R163, R201, R207, R215, R221	17	Yageo	RT0603FRE0710RL
56	R48, R49	2	Panasonic	ERJ-6DQF4R7V
57	R50, R82, R99, R107, R112, R120, R133, R146, R153, R160, R166, R204, R210, R218, R224	15	Vishay	CRCW0603100RFKEAC
58	R53, R54, R55, R56, R57	5	KOA Speer	RK73Z1JTDD
59	R58, R59	2	Vishay	CRCW0603127RFKEA
60	R60, R61, R227	3	Bourns	CRM2512-JW-6R8ELF
61	R70, R71, R72, R73, R75, R76, R77, R78, R79	9	Rohm	KTR18EZPF3573
62	R74, R80	2	KOA Speer	RK73H1JTDD4021F
63	R81	1	Yageo	RT0603BRD078K2L
64	R83	1	Yageo	RT0603BRE072K2L
65	R84	1	Yageo	RC0603FR-07499KL
66	R85, R86, R87, R88	4	Ohmite	TWW10J10RE
67	R89	1	TT Welwyn	PCF0805R-2K0BT1
68	R90, R91, R92, R93, R94, R95, R96, R97, R98, R101, R102, R103, R173, R174, R175, R176	16	KOA Speer	HV732HTTE1004F
69	R100, R171, R177, R179, R180, R181, R182, R183, R184, R185, R186, R187, R188, R189, R190, R191, R194, R195	18	Yageo	AC0603FR-1310KL
70	R105, R110	2	Panasonic	ERJ-P06F10R0V
71	R114, R115, R116, R117, R121, R122, R123, R124, R127, R128, R129, R130, R134, R135, R136, R137, R140, R141, R142, R143, R147, R148, R149, R150	24	Rohm	KTR18EZPF1004
72	R118, R125, R131, R138, R144, R151	6	KOA Speer	RN73H1JTDD2001B25
73	R119, R126, R132, R139, R145, R152	6	Vishay Dale	TNPW06038K06BEEA
74	R155, R161, R162, R168, R199, R205, R206, R212, R213, R219, R220, R226	12	Vishay	CRCW060322R1FKEA
75	R156, R164, R200, R208, R214, R222	6	Panasonic	ERJ-P06F1001V
76	R158, R159, R165, R167, R202, R203, R209, R211, R216, R217, R223, R225	12	Panasonic	ERJ-P06F47R0V



77	R172, R178	2	Yageo	RC0603FR-071KP
78	R192, R193	2	Vishay	CRCW0603274RFKEA
79	R196, R197, R198	3	Isabellenhütte	SMT-R010-1.0
80	R228, R233	2	Vishay	CRCW06032K43FKEA
81	R229, R234	2	Walsin Technologies	WR06X8063FTL
82	R230, R235	2	Yageo	AC0603FR-0775KL
83	R231, R236	2	Vishay Dale	CRCW0603210KFKEA
84	RL1, RL2	2	TE Connectivity	RTS3L012
85	RN1, RN2, RN3, RN6, RN9, RN10	6	Bourns	CAY16-103J4LF
86	RN4, RN5, RN11	3	Yageo	TC164-JR-07100RL
87	RN7, RN8	2	Yageo	TC164-JR-07390RL
88	T1, T2	2	Pulse	PH0416NLT
89	TP1, TP3, TP5, TP6, TP7, TP8, TP9, TP10, TP11, TP17, TP18, TP19, TP20, TP51, TP52, TP53, TP54, TP_1, TP_2, TP_DAC1	20	Keystone Electronics	5010
90	TP2, TP4, TP12, TP16, TP25, TP28, TP50, TP_GND1	8	Keystone Electronics	5011
91	TP13, TP14, TP15, TP22, TP26, TP27, TP29, TP30	8	Keystone Electronics	5013
92	TP31, TP34, TP36, TP43, TP44, TP45, TP46, TP48, TP55, TP57, TP59, TP61	12	Keystone Electronics	5127
93	TP32, TP33, TP35, TP37, TP38, TP39, TP40, TP41, TP42, TP47, TP49, TP56, TP58, TP60, TP62	15	Keystone Electronics	5012
94	TP63, TP65, TP67	3	Keystone Electronics	5014
95	TP64, TP66, TP68	3	Keystone Electronics	5126
96	TP_Boost1, TP_FAN1, TP_HBH1, TP_HBL1, TP_MUX1, TP_MUX2, TP_MUX3, TP_RL1, TP_RX1, TP_THDcH1, TP_THDcL1, TP_TX1	12	Keystone Electronics	5129
97	TVS1, TVS2, TVS3	3	TDK EPCOS	B72214S2271K101
98	U1, U2, U17	3	Texas Instruments	OPA4388ID
99	U3	1	Infineon	1EDC20H12AHXUMA1
100	U4, U6	2	Texas Instruments	SN74LVC8T245PWR
101	U5	1	Texas Instruments	REF2030QDDCRQ1
102	U7	1	Nexperia	74AXP1T45GWH



103	U8	1	Texas Instruments	TPS79533DCQ
104	U9	1	Microchip	MCP1804T-5002I/MB
105	U11, U12	2	Broadcom Avago	ACPL-C87A-000E
106	U13	1	Analog Devices	ADUM210N1BRIZ
107	U14	1	Analog Devices / Linear Technology	LTC6992CS6-1#TRMPBF
108	U15, U16	2	Infineon	1EDC10I12MHXUMA1
109	U18, U22, U23	3	Infineon	2ED020I12F2XUMA1
110	U20	1	ACEINNA	MCA1101-50-5
111	U21	1	ACEINNA	MCA1101-20-5
112	U24, U25	2	Analog Devices / Linear Technology	LT8301ES5#TRMPBF
113	XF1	1	Bourns	2027-47-BLF

## 8.2 AUX PS card

Nr.	Designator	Qty.	Manufacturer	Type
1	C1, C2	2	KEMET	C2220C104KDRACTU
2	C3	1	Murata	GRM31A5C3A331JWA1D
3	C4	1	KEMET	C0805C471J2GACTU
4	C5, C12, C14, C23	4	Murata	GCJ188R71H104KA12D
5	C6, C7	2	Panasonic	EEU-FM1E471LJ
6	C8	1	Nichicon	UPW1E151MPD1TD
7	C9, C10	2	Murata	GRM32ER61E226KE15L
8	C11	1	Panasonic	50SVPF10M
9	C13	1	KEMET	C971U472MVWDBA7317
10	C15, C18	2	TDK	C2012X7R1H225K125AC
11	C16	1	TDK	C3216X5R1E106K160AB
12	C17	1	Murata	GRM1885C1H470JA01D
13	C19	1	Murata	GRM1885C1H102JA01D
14	C21	1	Murata	GRM1885C1H221JA01D
15	C22	1	Murata	GCJ188R71H333KA12D
16	D1	1	Littelfuse	DSTD5200



17	D2	1	STMicroelectronics	STTH112A
18	D3	1	Comchip	BAS521-HF
19	D4	1	Nexperia	PMEG3020EJ,115
20	D5	1	Nexperia	BAT754S,215
21	D6	1	Würth Electronics	150060VS75000
22	FB1, FB2, FB3	3	Murata	BLM18KG260TH1D
23	L1, L2	2	Coilcraft	LPS4018-105MRC
24	L3	1	TDK	CLF6045NIT-3R3N-D
25	L4	1	TDK	ACM4520-901-2P-T000
26	L5	1	Coilcraft	LPS3015-682MRC
27	OC1	1	Vishay Lite-On	LTV-817S-TA1-B
28	R1, R7, R8	3	Panasonic	ERJ-P08J680V
29	R2, R4, R9, R11	4	Panasonic	ERJ-P08F4703V
30	R3, R10	2	Rohm	KTR18EZPJ565
31	R5	1	TE Connectivity	CRGP2010F68K
32	R6	1	Vishay	CRCW120633R2FKEAC
33	R12	1	TE Connectivity	CRGH0805F22R
34	R13	1	Panasonic	ERJ-P08J104V
35	R14, R27	2	Vishay Dale	CRCW0603100KFKEC
36	R15	1	Vishay	CRCW060354K9FKEA
37	R16	1	Vishay	CRCW060320K0FKEA
38	R17	1	Yageo	RC0805FR-0713KL
39	R18, R25	2	Vishay	CRCW060310K0FKEA
40	R19	1	Vishay Dale	CRCW060330K0FKEAC
41	R20	1	Panasonic	ERJB1BF1ROU
42	R21	1	Vishay	CRCW06033K01FKEA
43	R22	1	Panasonic	ERJ-3EKF3832V
44	R23	1	Vishay Dale	CRCW06031K00FKEC
45	R24	1	Vishay	CRCW060368K1FKEA
46	R26	1	Panasonic	ERJ-P06F1401V
47	U1	1	Rohm	BM2SC123FP2-LBZE2
48	U2	1	Texas Instruments	LMR16006YQDDCRQ1
49	U3	1	ON Semiconductor / Fairchild	LM431SCCM3X

### 8.3 INV GD PS card

Nr.	Designator	Qty.	Manufacturer	Type
1	C1, C2, C3, C8	4	TDK	C2012X7R1H225K125AE
2	C4, C6	2	Murata	GCJ188R71H104KA12D
3	C5	1	TDK	C2012X6S1H475K125AC
4	C7	1	Murata	GRM1885C1H470JA01D
5	D1, D3, D5, D7, D9	5	Nexperia	BAT46WJ,115
6	D2, D4, D8, D10	4	Würth Electronics	150060VS75000
7	D6	1	Nexperia	PDZ33B,115
8	FB1	1	Murata	BLM18KG260TH1D
9	J1, J2, J3, J5	4	TE Connectivity	826662-2
10	J4	1	TE Connectivity	826662-3
11	R1, R2, R4, R8	4	Vishay	CRCW06032K43FKEA
12	R3	1	Panasonic	ERJ-3EKF1580V
13	R5	1	Yageo	RC0603FR-07806KL
14	R6	1	Vishay	CRCW060340K2FKEA
15	R7	1	Vishay Dale	CRCW0603210KFKEA
16	Tr1	1	Pulse	PG1895NLT
17	U1	1	Analog Devices / Linear Technology	LT8301ES5#TRMPBF

### 8.4 MUX GD card

Nr.	Designator	Qty.	Manufacturer	Type
1	C1, C4, C7, C11, C13	5	Murata	GCJ188R71H104KA12D
2	C2, C5, C8	3	KEMET	C0603C101J1GAC
3	C3, C6, C9	3	Murata	GCM21BR71H105MA03L
4	C10, C15, C16	3	TDK	C2012X7R1H225K125AE
5	C12	1	TDK	C2012X6S1H475K125AC
6	C14	1	Murata	GRM1885C1H470JA01D
7	D1, D4, D5, D7	4	Nexperia	BAT46WJ,115
8	D2, D6, D8	3	Würth Electronics	150060VS75000
9	D3	1	Nexperia	PDZ33B115



10	FB1	1	Murata	BLM18KG260TH1D
11	J1, J2, J4	3	TE Connectivity	826662-2
12	J3	1	TE Connectivity	826662-4
13	R1, R2, R4, R5, R8, R9, R11, R12, R15, R16, R18, R19	12	Yageo	RC0603FR-13221RL
14	R3, R10, R17	3	Vishay	CRCW060310R0FKEA
15	R6, R13, R20	3	Walsin Technologies	WR06X1000FTL
16	R7, R14, R21	3	Vishay	CRCW060310K0FKECC
17	R22, R25, R28	3	Vishay	CRCW06032K43FKEA
18	R23	1	Panasonic	ERJ-3EKF1580V
19	R24	1	Yageo	RC0603FR-07806KL
20	R26	1	Vishay	CRCW060340K2FKEA
21	R27	1	Vishay Dale	CRCW0603210KFKEA
22	Tr1	1	Pulse	PG1895NLT
23	U1, U2, U3	3	Infineon	1EDC05I12AHXUMA1
24	U4	1	Analog Devices / Linear Technology	LT8301ES5#TRMPBF