



Vincotech

Reference Design



Gate driver for M40x-M80x Power Modules

GD-M40x-80x for NPC Modules

Table of Contents

1	Introduction	3
2	Features of Driver Board	8
2.1	Main Features	8
2.2	Electrical Parameters	9
2.3	Channel Assignment	10
2.4	Pin assignments and connectors for operation	11
2.5	Mechanical Dimensions	12
3	Description of Electrical Parts	13
3.1	Power Module	13
3.2	Required power supplies	13
3.3	Input / output signals	13
3.4	Temperature Measurement output	13
3.5	PCB – Power Supply	14
3.6	PCB – CTR Input and Output	16
3.7	PCB – Temperature	18
3.8	PCB – Booster	19
3.8.1	Active voltage clamp	21
4	Schematics	22
5	Short Circuit Protection	25
6	BOM	30
6.1	BOM Control Module	30
6.2	BOM Thermal Module	31
6.3	BOM Power Supply Module	31
6.4	BOM Current Booster Module	32



Revision history:

Date	Revision Level	Description	Page number(s)
Dec 2014	1	First release	31

1 Introduction

This application note describes the Evaluation Driver Kit for the module family M40x-M80x or in other words the *flow*NPC 4w , *2xflow*NPC 4w and *3xflow*NPC 4w 2400V Standard NPC generation. The topology used in these modules is the Neutral Point Clamped which has 1200 V components in outer-inner switch positions. Asymmetrical inductance for low turn off inductance utilized parasitic inductance for reduced turn on losses > no low inductive bus bars. The board provides a plug and play solution identifying the switching behavior and efficiency of this module family.

The M40X module family is available as a single phase 400A/2400V or three phase 3X400A/2400V topology; in order to drive both requires one or three GD-M400-MASTER-s. The M80X module family is a single phase 800A/2400V topology, in order to drive it requires: GD-M400-MASTER + GD-M400-SLAVE connected in MASTER-SLAVE configuration.

This is the first module that carries a high power PCB with asymmetrical inductance. Asymmetrical inductance reduces switching losses by 10% to 30%, depending on the parasitic inductance, while extending the safe operating range at turn-off (RBSOA). Detailed information is available in Vincotech's webpage www.vincotech.com.

The following picture shows the MASTER configuration. This kit can be used to drive the complete range of M40X modules.

- 1. current boost PCB
- 2. controller PCBs for input and output signals
- 3. power supply PCB
- 4. Temperature PCB for thermistor signal conditioning

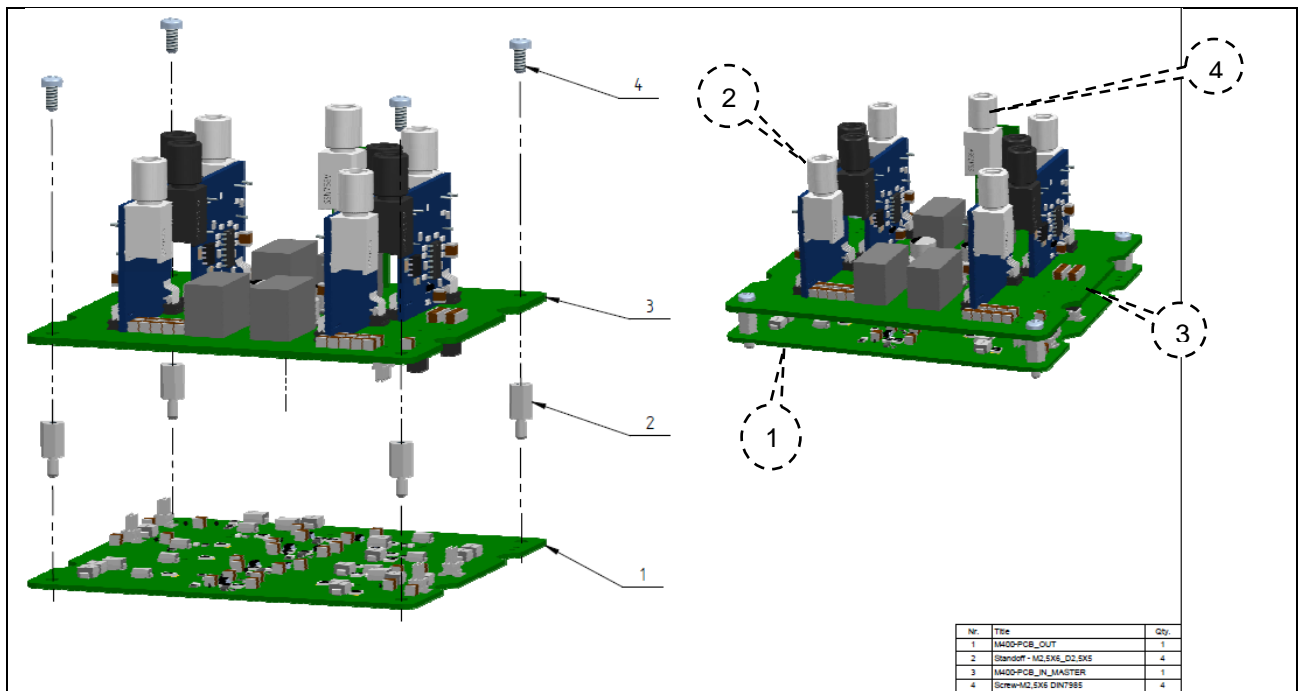

Figure 1: Evaluation driver board in MASTER configuration

Ordering numbers for M40X (one module – one MASTER gate driver)

Ordering numbers for M80X (one module – one MASTER+one SLAVE+one CONNECTION CABLE kit)

Module	GATE DRIVER	Connection cables
M40X	GD-M400-MASTER	N.A.
M80X	GD-M800-MS	included

Table 1: Ordering numbers

The following picture shows the SLAVE configuration. This kit can be used only in MASTER-SLAVE configuration to drive the M80X

- 1. current boost PCB
- 3. power supply PCB
- 4.PCB for thermistor signal conditioning

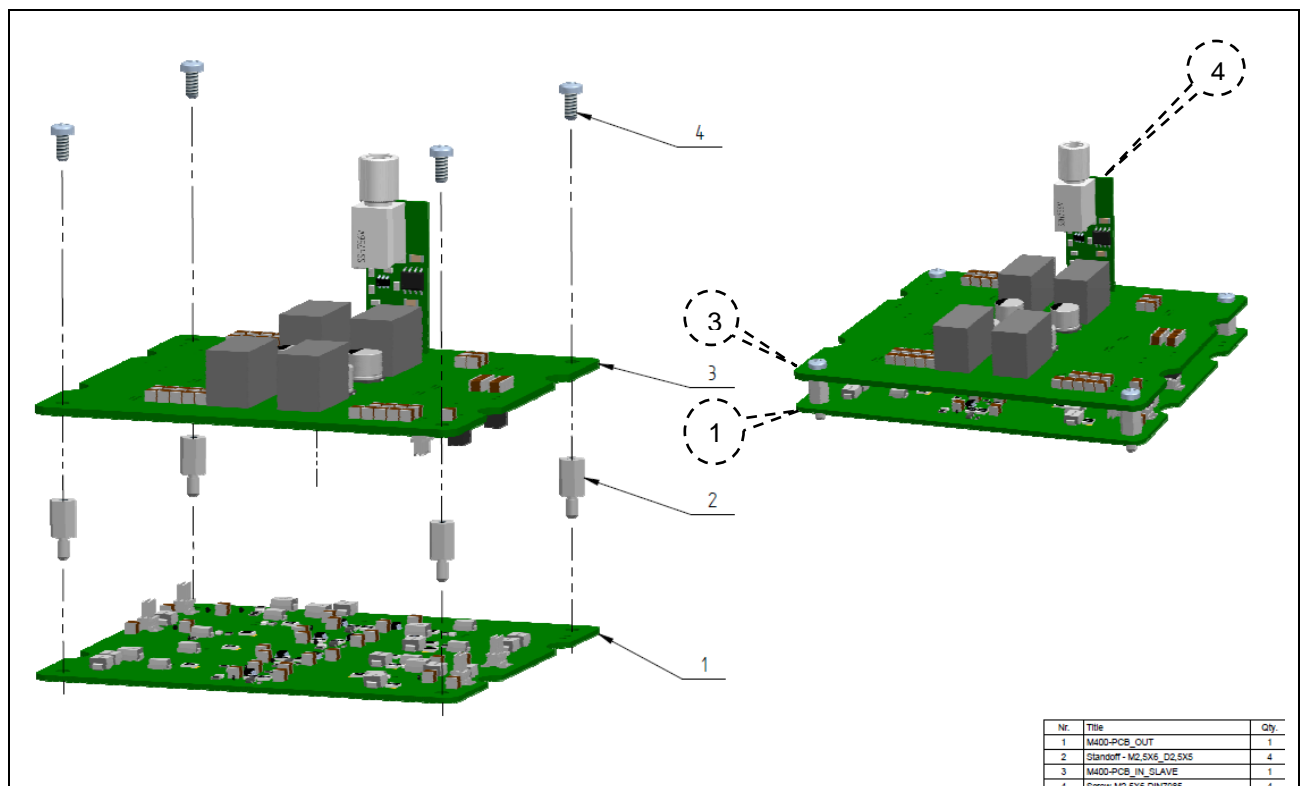

Figure 2: Evaluation driver board in SLAVE configuration

The MASTER-SLAVE configuration is shown on figure 3

The MASTER-SLAVE configuration is intended to drive the M80X

- 1. GD-M400-MASTER
- 2. GD-M400-SLAVE
- 3. GD-M800-MS-CONN

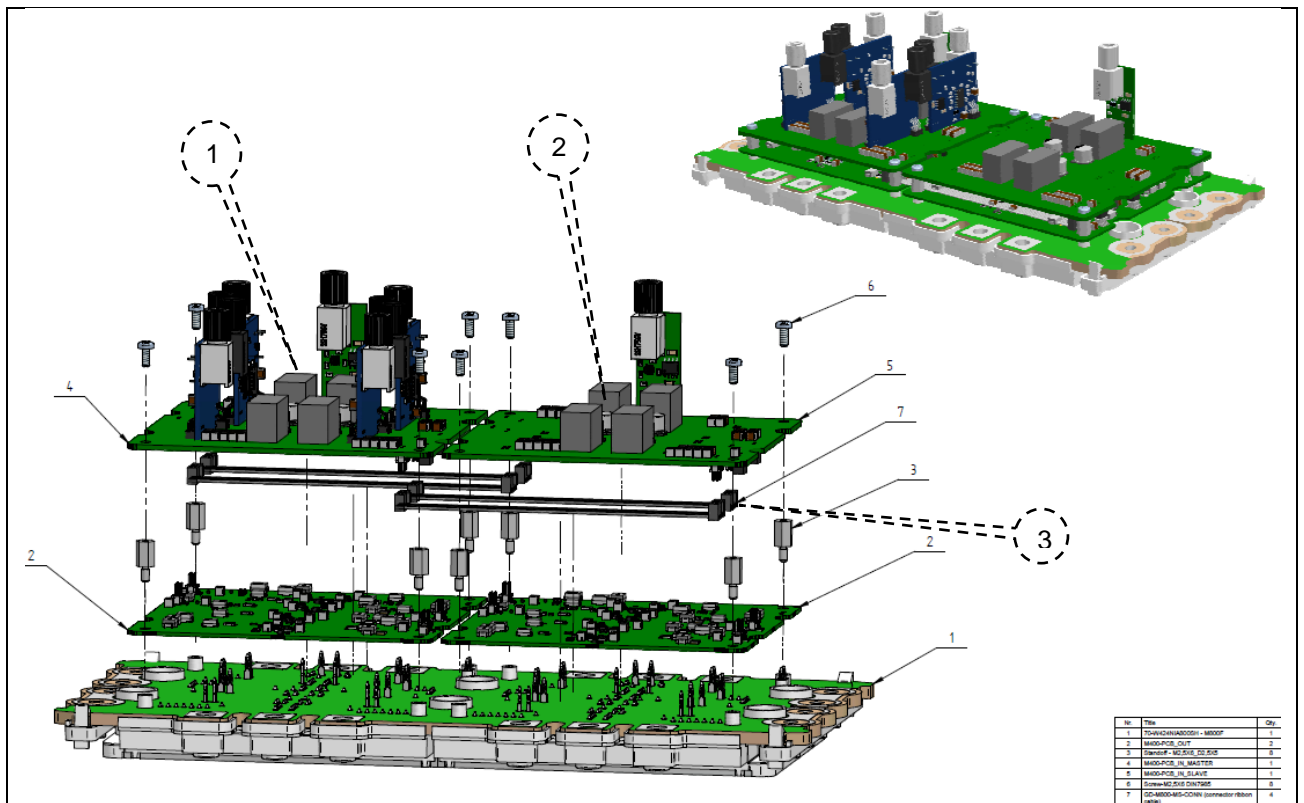

Figure 3: Evaluation driver board in MASTER-SLAVE configuration

2 Features of Driver Board

The next chapter describes the main features, basic electrical parameters as well as pin assignments and mechanical dimensions.

2.1 **Main Features**

- Four drivers for each switch
- Single 15 V power supply input with 3000VAC isolation
- Gate voltage of -8 V / +16 V
- Voltage for each switch is generated by a DC/DC converter
- Non-inverting PWM inputs
- Optical Fiber Input and Output signals
- Desaturation protection
- Two level turn-off with 10 V intermediate level
- Active miller clamp
- Under voltage lockout
- Fault output signal (active high) for each switch
- Isolated PWM coded heatsink temperature sense with thermistor on each 400A unit
- Gate drive current of ± 20 A peak
- Active voltage clamp
- PCB designed to fulfill the requirements of IEC61800-5-1, pollution degree 2, over voltage category III

2.2 Electrical Parameters

The electrical characteristics involve the guaranteed value spread for the supply voltage, load and processes. Unless otherwise noted all voltages are given with respect to ground (GND).

Positive currents are assumed to be flowing into pins.

	min.	typ.	max.	Unit	Remarks
U_{CE} – max for IGBT/FWD			1200	V	
P_{max} – max output power supply			2	W	
U_S – supply voltage for drivers	14,5	15	15,5	V	See note 1
I_S – Input current no load / full load		30/250		mA	For 1 dc/dc converter
Gate drive supply voltage positive	16,5	17	18	V	$14,5V < V_{in(DC/DC)} < 15,5V$
Gate drive supply voltage negative	-7	-8,7	-10	V	$14,5V < V_{in(DC/DC)} < 15,5V$
Under voltage lockout	14	14,5	15	V	UVLO top threshold
Under voltage lockout	13	14	14,5	V	UVLO bottom threshold
Desaturation protection		7		V	
f_{sw} – switching frequency		8	16	kHz	See note 2
T_a – Ambient temperature	-25		70	°C	
T_{ST} – Storage temperature	-40		85	°C	
Peak Wavelength of fiber optics R/T		660		nm	
Photosensitivity Spectral Range (S = 80% Smax)	600		780	nm	
Gate drive supply isolation voltage			3000	VAC	1 minutes See note 3
For additional information refer to the datasheet of TD350 from ST					
Note 1: The secondary voltage for the gate drive will change with the same ratio.					
Note 2: Limitation by IGBT losses					
Note 3: For conformance with IEC 62109-1 the input supply of the DC-DC converter (15V) should be connected to the inverter neutral potential					

Table 2: Electric parameters

The following table shows different modules available in the M40x-M80x series. Here information about the maximum/recommended switching frequency and the assembled passive components are mentioned.

Module	M400F	M800F
Nominal chip current [A]	400	800
Maximum frequency ¹ [kHz]	43	43
Recommended frequency [kHz]	20	20
Gate resistors $R_{G_{ext on}}$ [Ω]	1,25	1,25
Gate resistors $R_{G_{ext off}}$ [Ω]	1,25	1,25
Gate resistors $R_{G_{int}}$ [Ω] buck IGBT	0,5	0,5
Gate resistors $R_{G_{int}}$ [Ω] boost IGBT	1,875	1,875
Gate emitter resistor R_{GE} [Ω]	15K	15K
Gate emitter capacitor C_{GE} ² [μ F]	n.a.	n.a.
¹ : Limit given by the output power of power supply		
² : not assembled		

Table 3: Members of M40x-80X family

2.3 Channel Assignment

The evaluation driver kit consists of four channels for the IGBTs and an additional channel for the temperature (NTC).

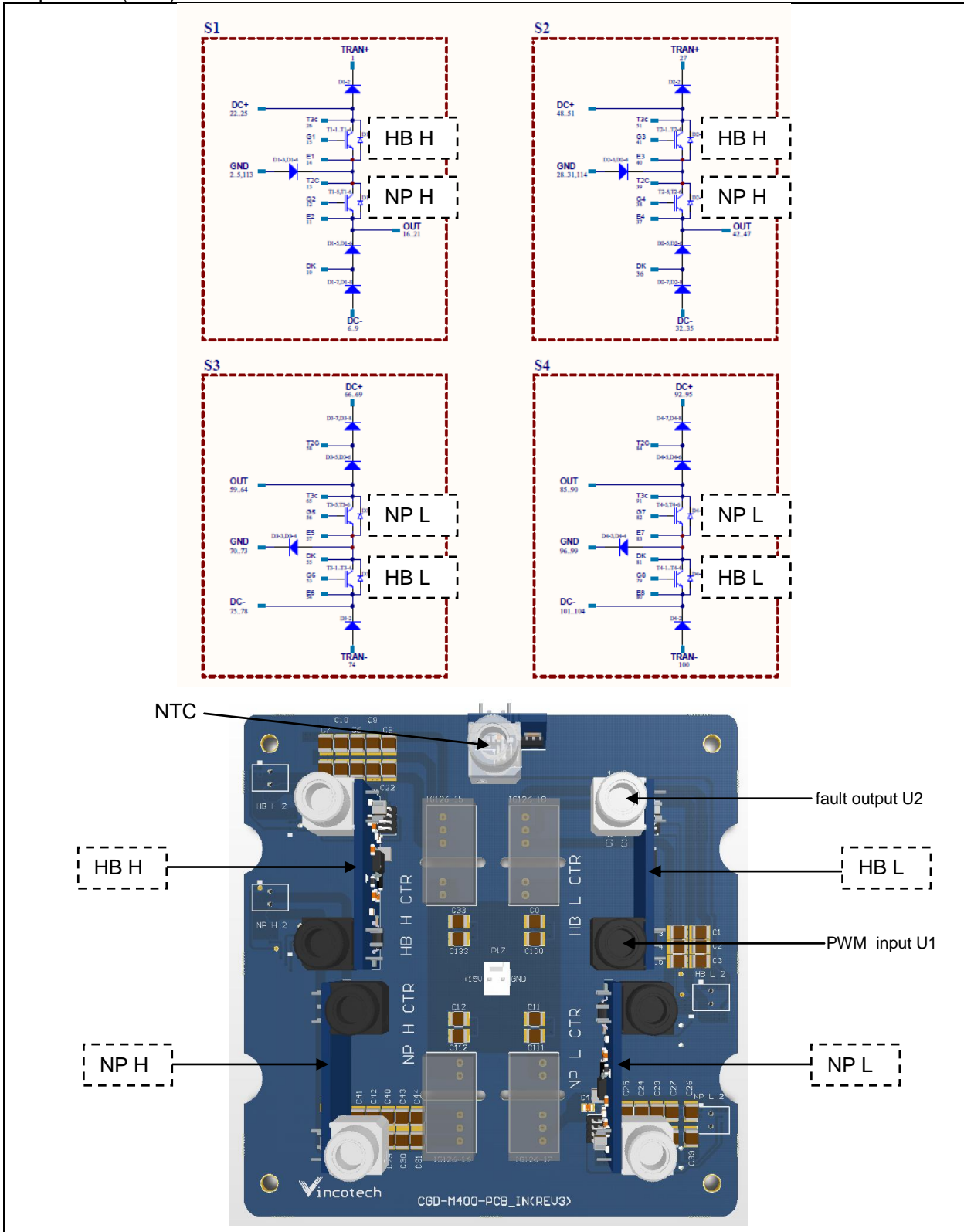

Figure 4: Assignment for channels

Pin assignments and connectors for operation

The driver board has connectors to provide the power to the PCB and to support signals to e.g. the driver circuit.

	P17 – Power Supply		
1	+15 V		
2	GND		
-for each channel		U1 – Input PWM signal -SFH551/1-1V digital receiver for optical data transmission with polymer optical fiber 2.2mm polymer 650nm	
-for each channel		U2 – Fault Output signal -SFH756V transmitter for optical data transmission with polymer optical fiber 2,2 mm 650nm	
-one per gate driver		U5 – Output temperature -SFH756V transmitter for optical data transmission with polymer optical fiber 2,2 mm 650nm	

Table 4: Pin assignment for connectors

2.4 Mechanical Dimensions

Mechanical dimensions for width, length and height (without module): **97.9 mm x 98.1 mm x 46 mm**

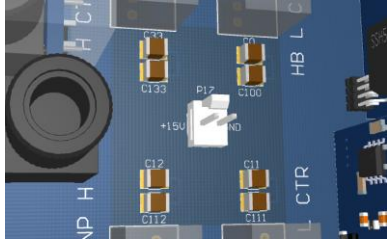
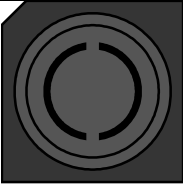
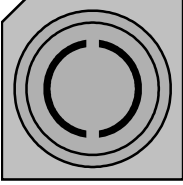
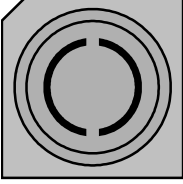
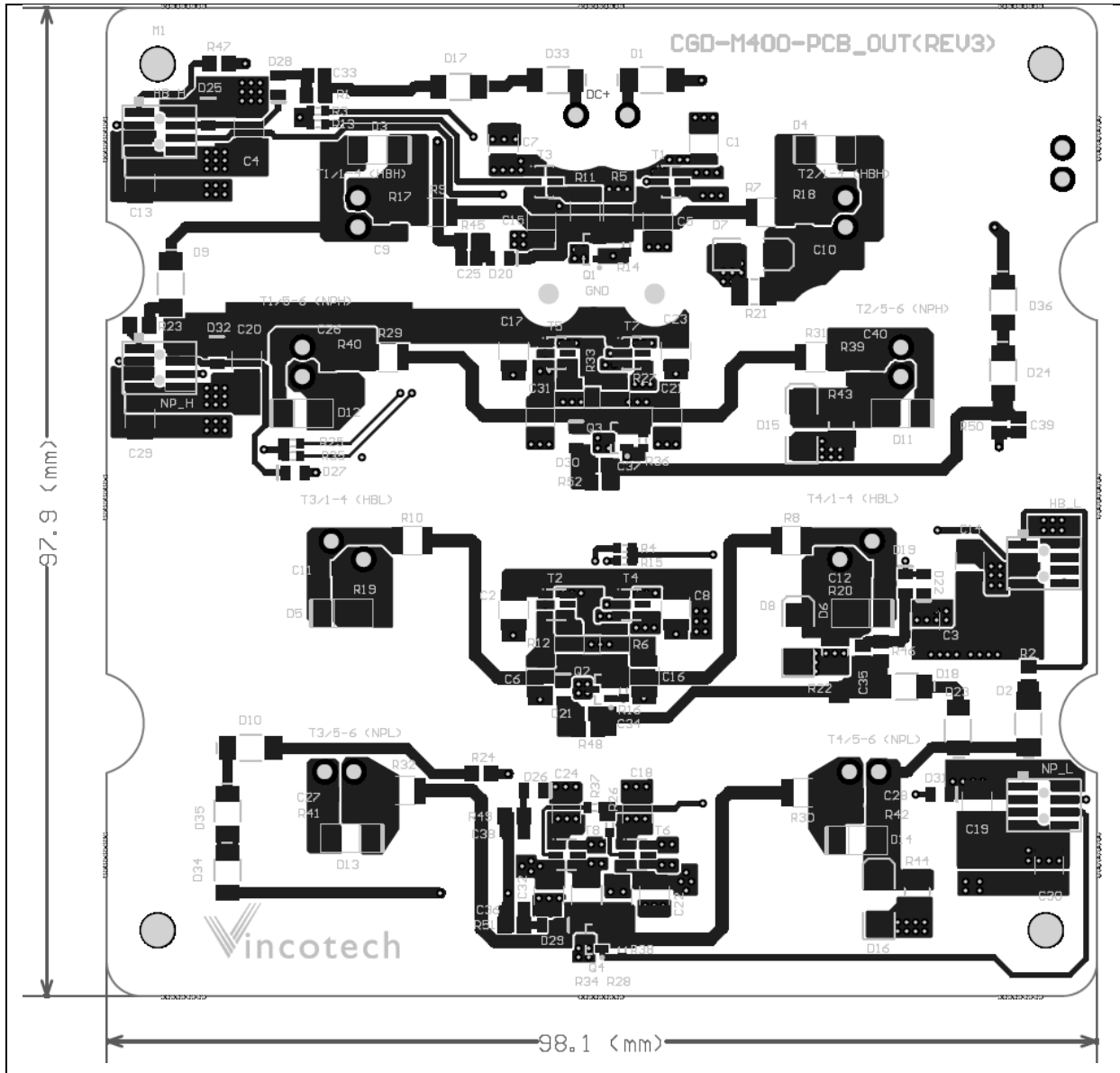

Figure 5: PCB of boost stage

3 Description of Electrical Parts

This chapter describes the different electrical parts like the input signals, output signals and driver circuit for a better understanding how the board works.

3.1 *Power Module*

This power module family is suitable for PV applications and for UPS applications. M40xP(F) modules are available in single phase and in three phase configuration based on a neutral point clamped topology which is also known as NPC topology. Two 1200V fast IGBTs with freewheeling diodes are implemented for the outer switch (BUCK STAGE) and for the inner switch another two 1200V IGBTs with freewheeling diodes are placed (BOOST STAGE). The IGBTs and the freewheeling diodes have the same current rating. Two diodes D_{tran+} , D_{tran-} will implement the regeneration of the energy stored in the parasitic inductance, and the asymmetrical inductance at work.

For temperature measurement a NTC is equipped. Note that this NTC has only a functional isolation.

3.2 *Required power supplies*

To ensure a correct operation of the evaluation kit one single +15 V power supply for all gate drivers. The +15 V has to be supported through the connector P17. In parallel MASTER-SLAVE operation the +15V at P17 has to be supplied at MASTER and SLAVE as well. The PWM input, FAULT and temperature measurement output are implemented via optical fiber, no addition power supply is required for the CTR cards.

3.3 *Input / output signals*

The switching of the IGBT inverter needs to be controlled by 4 channels for each phase. The dedicated input signals is the U1 (PWM IN) located on its own CTR card. Each switch has its own fault output activated by under voltage lockout or by desaturation supported through U2 (FAULT OUT) The output of the temperature is a PWM signal available on U5 TH card.

3.4 *Temperature output*

The temperature output is generated with a voltage-controlled pulse width modulator. It is supported to the fiber optic connector U5. The attached diagram gives the duty cycle as a function of the NTC temperature which is build in the power module.

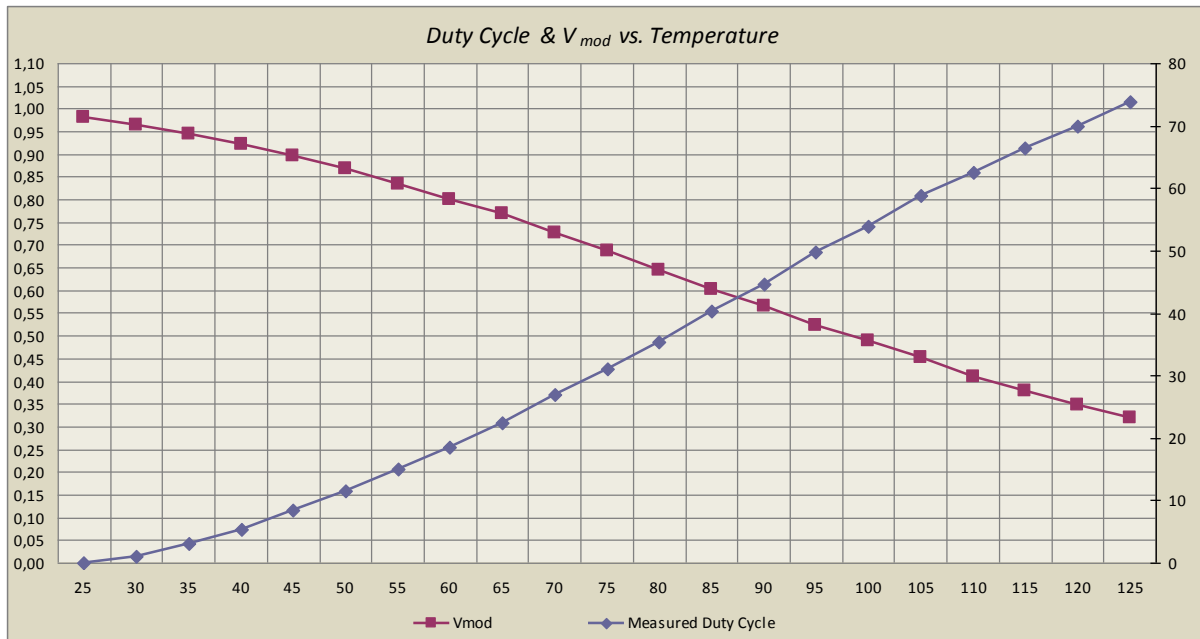

Figure 6: Duty cycle of temperature output

3.5 PCB – Power Supply

The power supply board supports all four channels of the M40x evaluation kit. A 15 V power supply has to be used to support the 2-pin connector in the middle of the PCB (P17). Four independent DC/DC converters are used on this board to generate +16 V / -8 V for each IGBT.

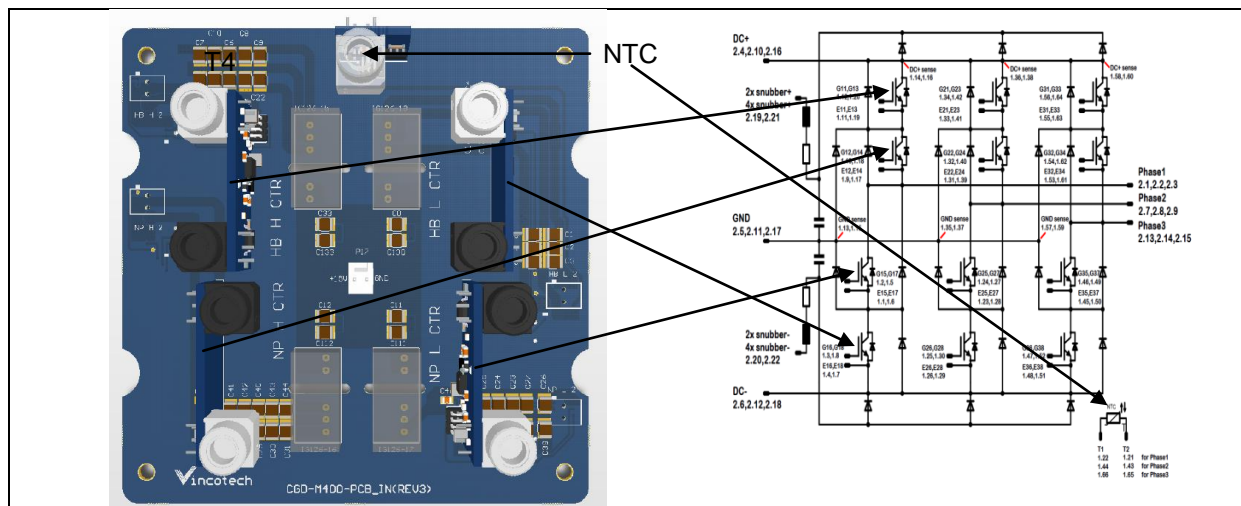

Figure 7: PCB of power supply

The asymmetric bipolar voltage for the IGBTs is generated by a DC/DC converter IG136-15

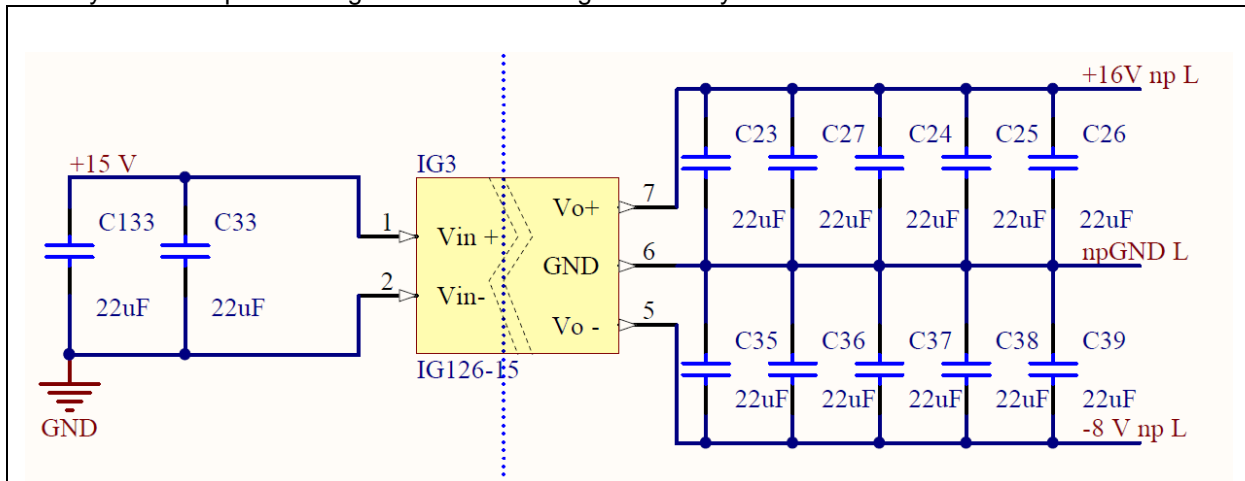

Figure 8: Bipolar voltage supply for e.g. T3 – neutral point low side

The DC /DC converter (IG136-15) is a 2 W, 15V input, +17V/-8,7V output with 3000VACrms I/O isolation.

Different connectors are used on the bottom side of the power supply PCB to supply the signals from the input, output and temperature PCB to the boost PCB.

Additional connectors on the bottom side of the power supply PCB are used for Master-Slave operation.

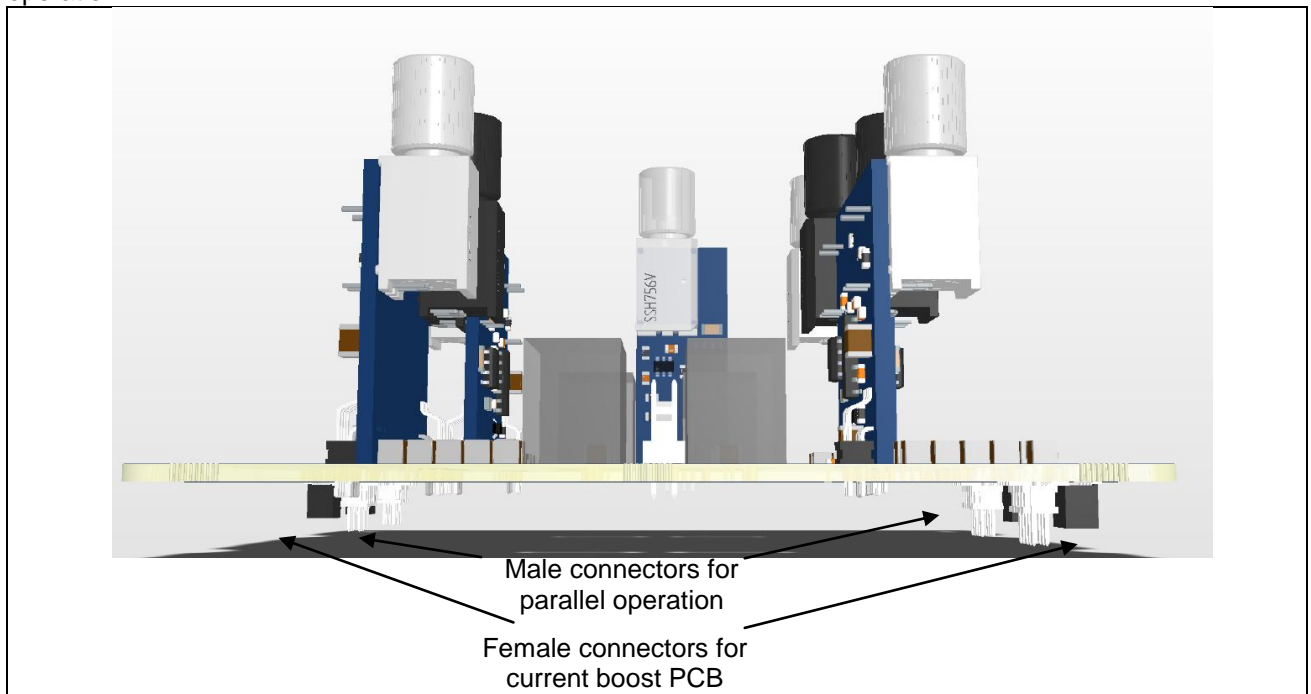

Figure 9: Connector for boost PCB and parallel operation

The pin assignment for the bottom connectors is like the following:

Connectors for boost PCB			Connectors for parallel operation		
Pin	Signal	Comment	Pin	Signal	Comment
1	desat np H	Desaturation protection	1	desat np H	Desaturation protection
2	+16V np 1-2	Positive supply voltage	2	+16V np 1-2	Positive supply voltage
3	out H np H	Output for PWM signal	3	out H np H	Output for PWM signal
4	V clamp npH	In Active Voltage clamp	4	V clamp npH	In Active Voltage clamp
5	-8V np 1-2	Negative supply voltage	5	-8V np 1-2	Negative supply voltage
6	clamp np H	Clamp	6	clamp np H	Clamp
7	npGND 1-2	Ground	7	npGND 1-2	Ground
8	nc/NTC*	not connected/NTC	8	npGND 1-2	Ground
			9	npGND 1-2	Ground
			10	npGND 1-2	Ground

* only for the HB L section

Table 5: Pin assignment for connectors, e.g. T2 – neutral point high side

3.6 PCB – CTR Input and Output

Four additional vertical mounted PCBs provide the PWM input signals for the IGBTs as well as fault signals coming from the IGBTs

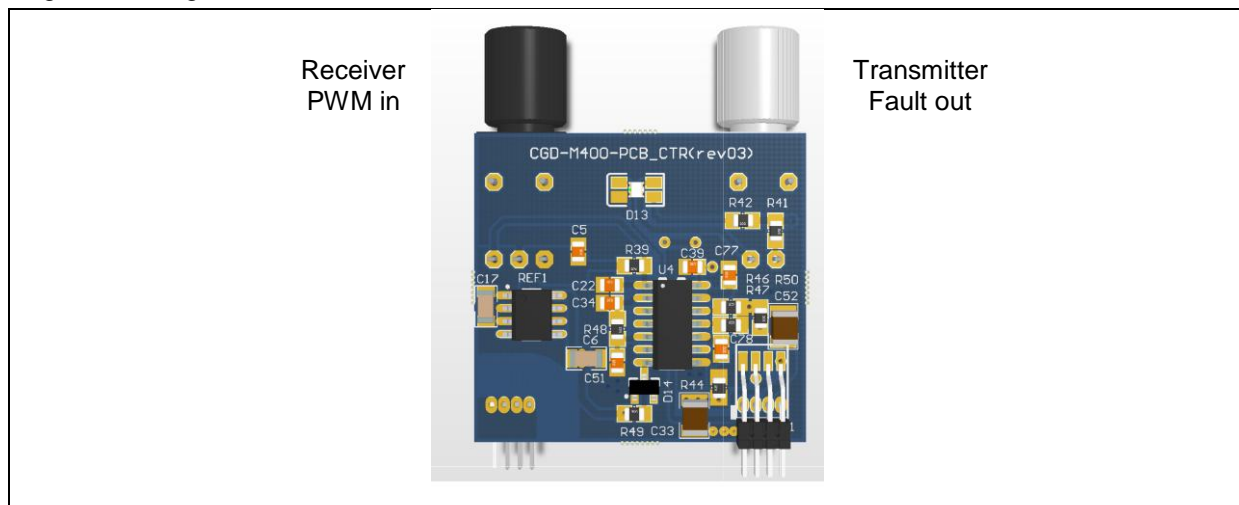

Figure 10: CTR- PCB with TD350E

During operation, the DESAT capacitor is discharged when TD350 output is low (IGBT off). When the IGBT is turned on, the DESAT capacitor starts charging and desaturation protection is effective after the blanking time (t_b)

$$t_b = 7.2[V] \cdot C_{39} / 250[\mu A]$$

When a desaturation event occurs, the fault output is pulled down and TD350 outputs are low (IGBT off) until the IN input signal is released (high level), then activated again (low level).

$$C_{39} = 100\text{pF}$$

In case of a short circuit the HB IGBT must be first turned off, in order to insure this sequence the desaturation capacitances for the NP IGBT-s are increased. Additional capacitances are placed on the power board (C45;C46)

Fault status output: the dedicated output pin of the IC is used to signal a fault event (desaturation, UVLO) to a controller. The fault pin drives direct the U2 fiber transmitter via a red colored LED. When a fault event is detected the red LED will light up.

Minimum ON time: In order to ensure the proper operation of the 2-level turn-off function, the input ON time (T_{win}) must be greater than the T_{winmin} value:

$$T_{winmin} = T_a + 2 \cdot R_{del} \cdot C_{s1} = 1,5 + 2 \cdot 0,5 \cdot 0,47 = 2\mu s$$

R_{del} is the internal discharge resistor of TD350E 0,5 k Ω (from the datasheet of TD350E)

Input signals smaller than T_a are ignored. Input signals larger than T_{winmin} are transmitted to the output stage after the T_a delay with minimum width distortion ($\Delta T_w = T_{wout} - T_{win}$).

For an input signal width T_{win} between T_a and T_{winmin} , the output width T_{wout} is reduced below T_{win} (pulse distortion) and the IGBT could be partially turned on. These input signals should be avoided during normal operation.

For more details see :

<http://www.st.com/web/en/resource/technical/document/datasheet/DM00023850.pdf>

3.7 PCB – Temperature

One vertical mounted PCB measures the module temperature using the internal NTC and provides optical information about the module temperature.

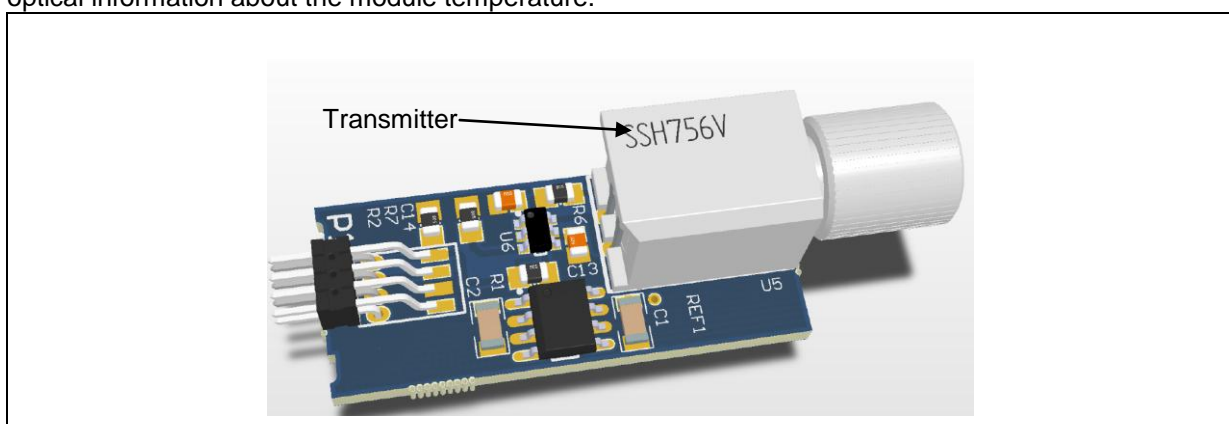

Figure 12: TH-PCB with LTC6992-1 (Voltage-Controlled Pulse Width Modulator)

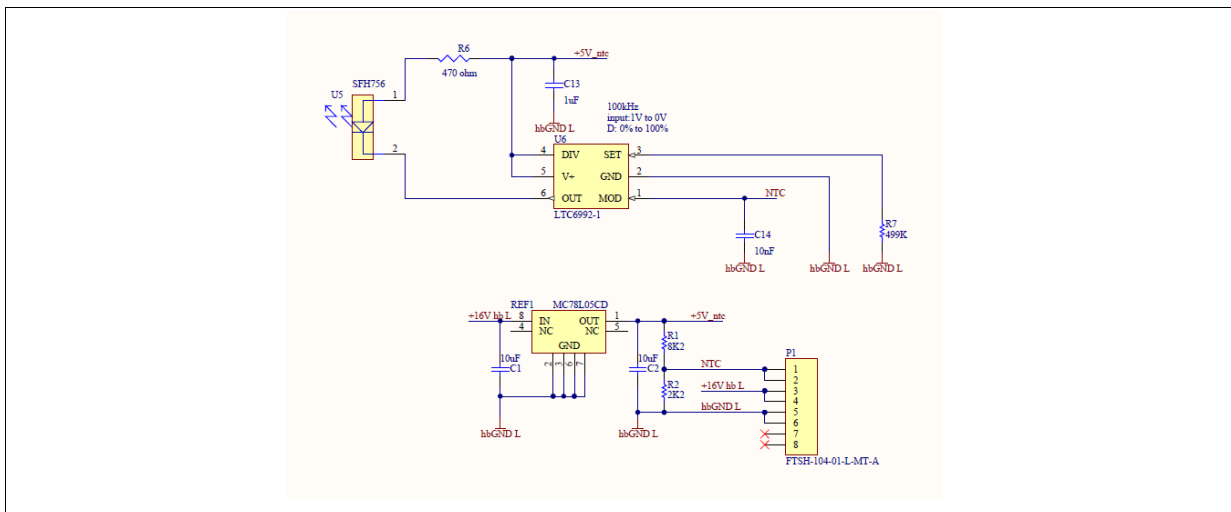

Figure 13: Schematic of the TH-PCB

The duty cycle of the PWM signal generated by the **LTC6992-1** is direct proportional to the measured temperature of the module. (Fig 6)
 An internal +5 V supply is required to power the **LTC6992-1**. The input of the +5 V is the +16 V hb L coming from the power supply PCB.

3.8 PCB – Booster

The boost PCB provides the needed gate current to drive the IGBTs. Four independent driver channels are assembled. It is supplied by the power supply PCB with +16 V and -8 V.

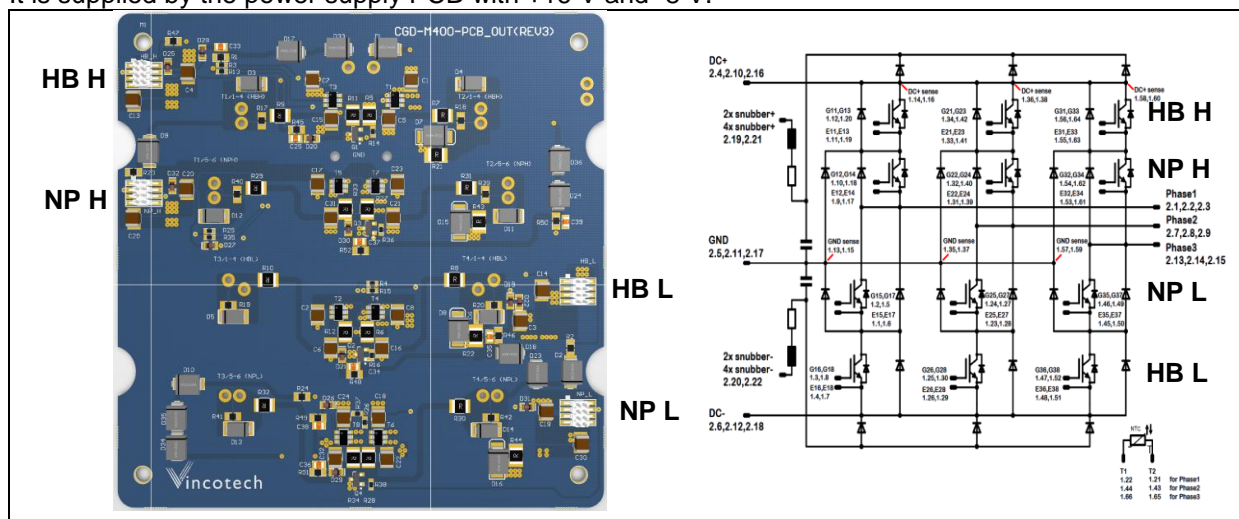

Figure 14: Current Booster PCB

The pin assignment for the connectors is like the following:

Connector: HB H ; HB L ; NP H ; NP L					
Pin	Signal HB H	Signal NP H	Signal NP L	Signal HB L	Comment
1	desat	desat	desat	desat	Desaturation protection
2	+16 V	+16 V	+16 V	+16 V	Positive supply
3	out high	out high	out high	out high	Signal for turn on/off

4	V clamp	V clamp	V clamp	V clamp	Active voltage clamp
5	-8 V	-8 V	-8 V	-8 V	Negative supply
6	clamp	clamp	clamp	clamp	Miller clamping
7	GND	GND	GND	GND	Ground
8	n.c.	n.c.	n.c.	NTC	not connected / NTC

Table 6: Pin assignment for connectors

The PCB has two current boost stages that are connected in parallel to provide a high gate current when necessary. The module has two gate pins. Each for half of the nominal module current. A common gate resistor as well as separated gate resistors are used for the gates and the common emitter.

The schematic to drive the IGBT is shown in the next figure as an example for HB L IGBT. The schematics for the other IGBT-s are the same.

3.8.1 Active voltage clamp

The rated blocking voltage of the semiconductor switch may never be exceeded. This requirement must be fulfilled under all working conditions including of course turn-off transients from over-current or short-circuit conditions. Due to the unavoidable stray inductances in the layout of the power stage and high values of the current change di/dt the over voltages in the range of few hundreds volts can be produced. In extrem cases these voltage spikes can take the values higher than the maximal permissible level of the collector-emitter voltage $V_{CE(max)}$. The zener diodes D23,D18 between collector and gate causes the gate to become turned on when the collector voltage reaches 1200 V

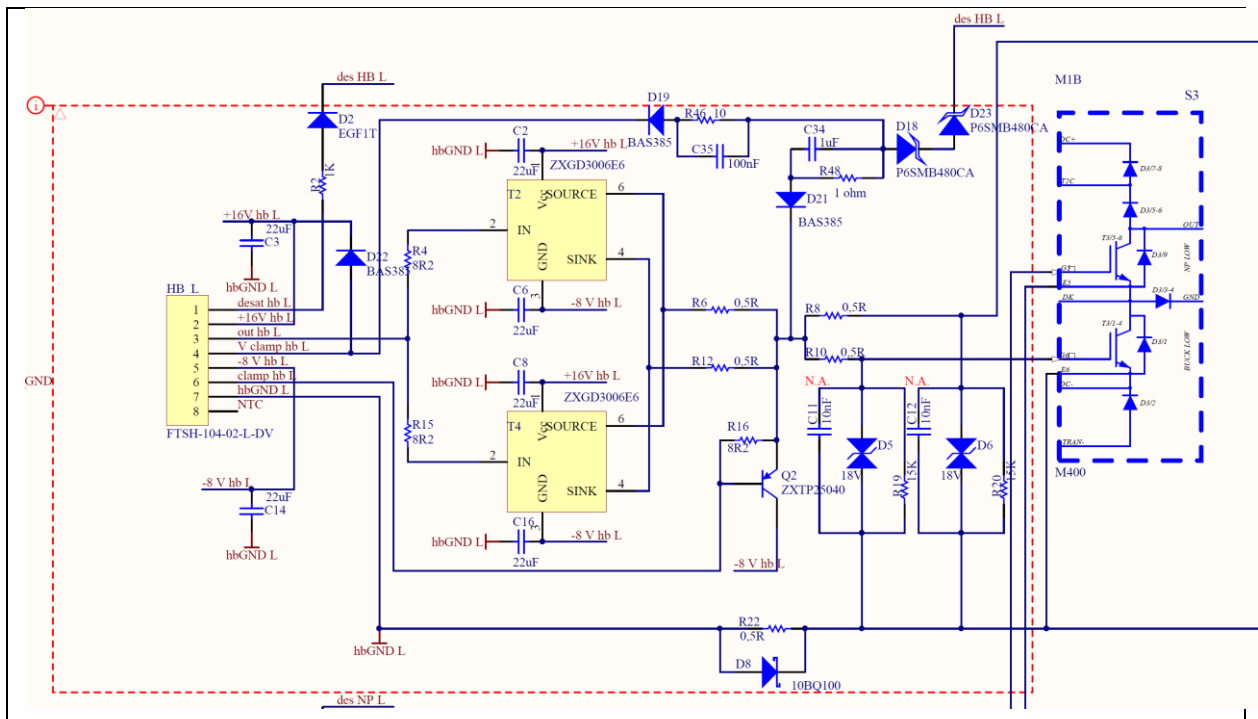

Figure15: Boost stage of HB L

4 Schematics

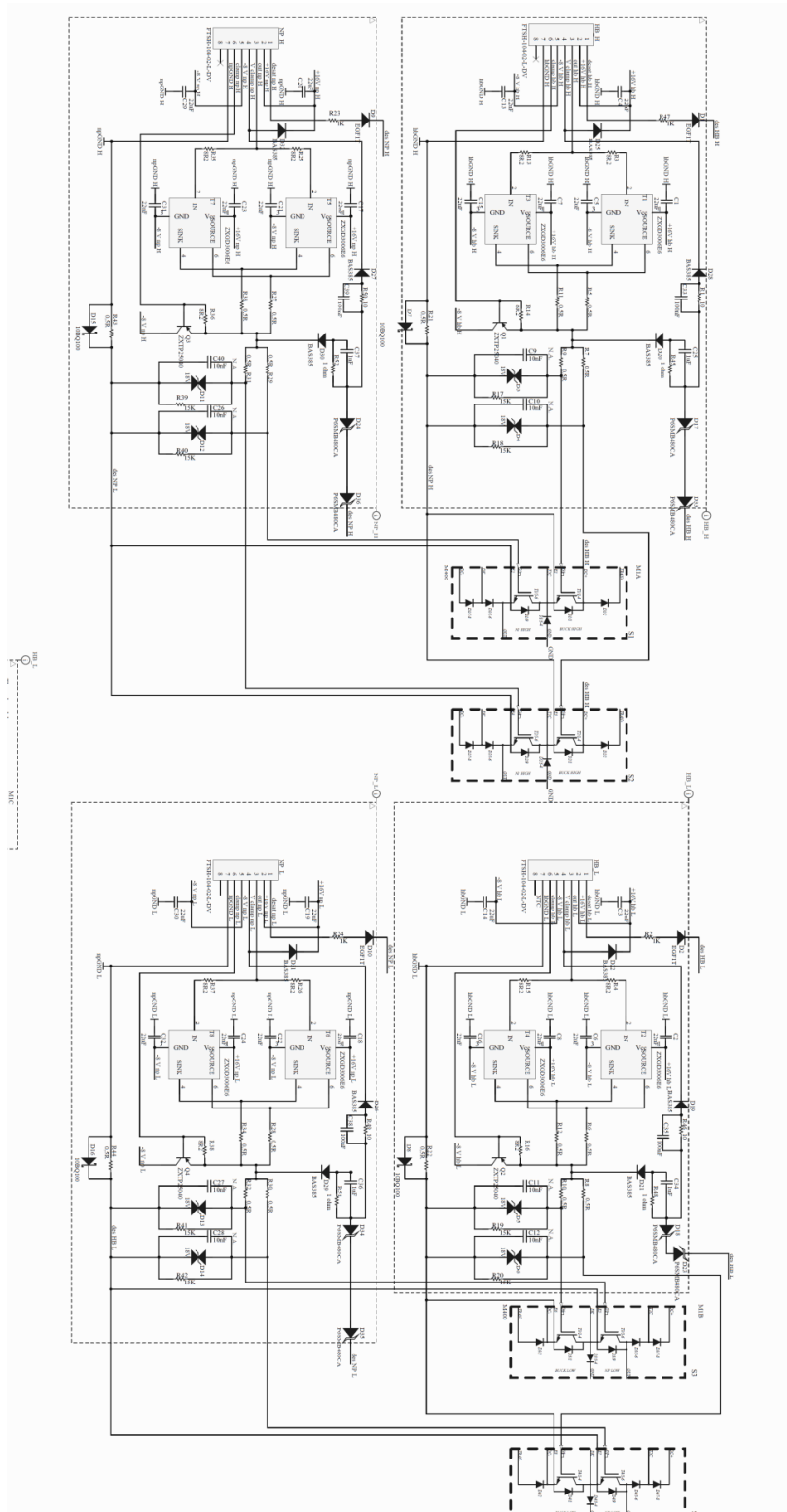

Figure16: Boost stage schematic

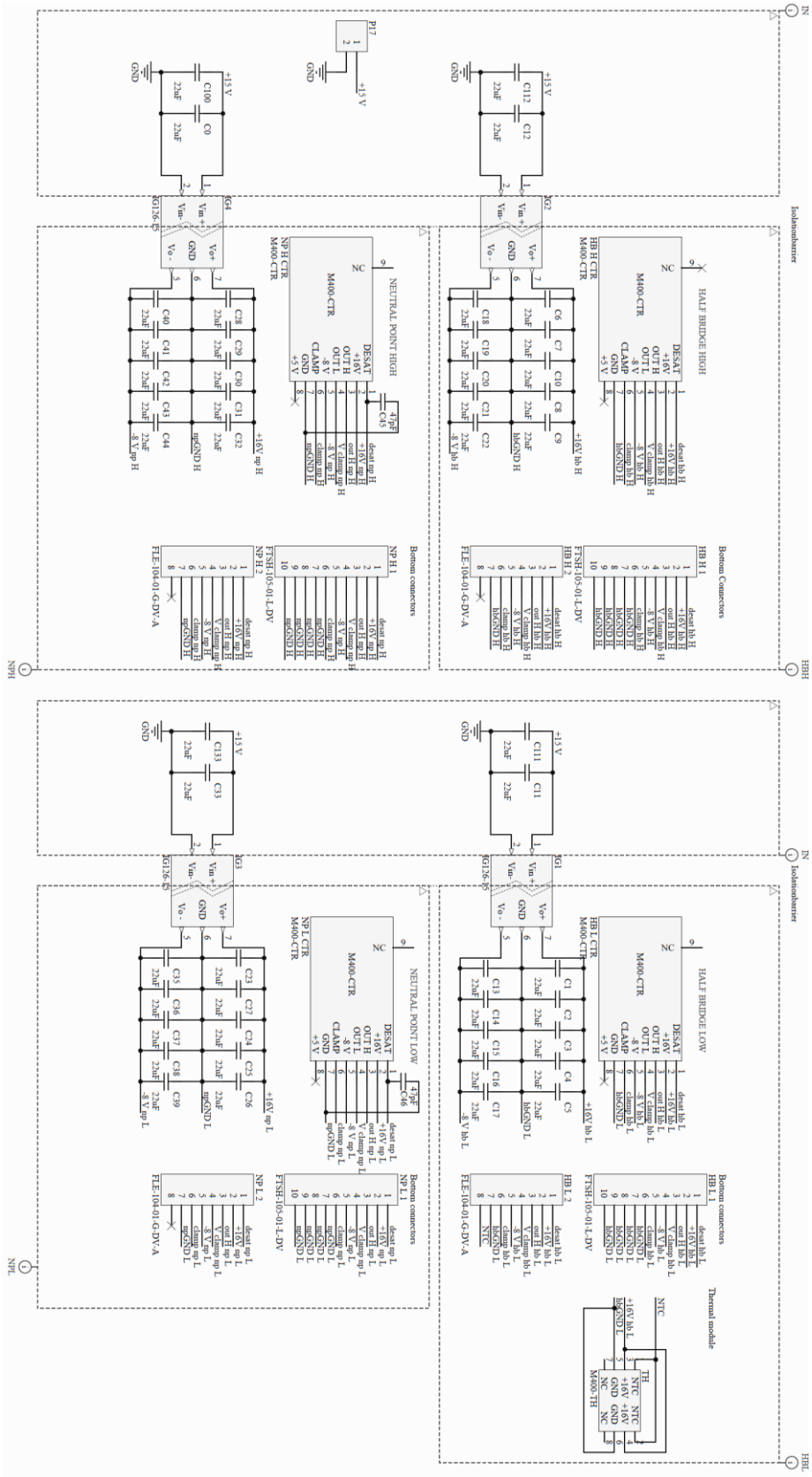

Figure17: Power stage schematic

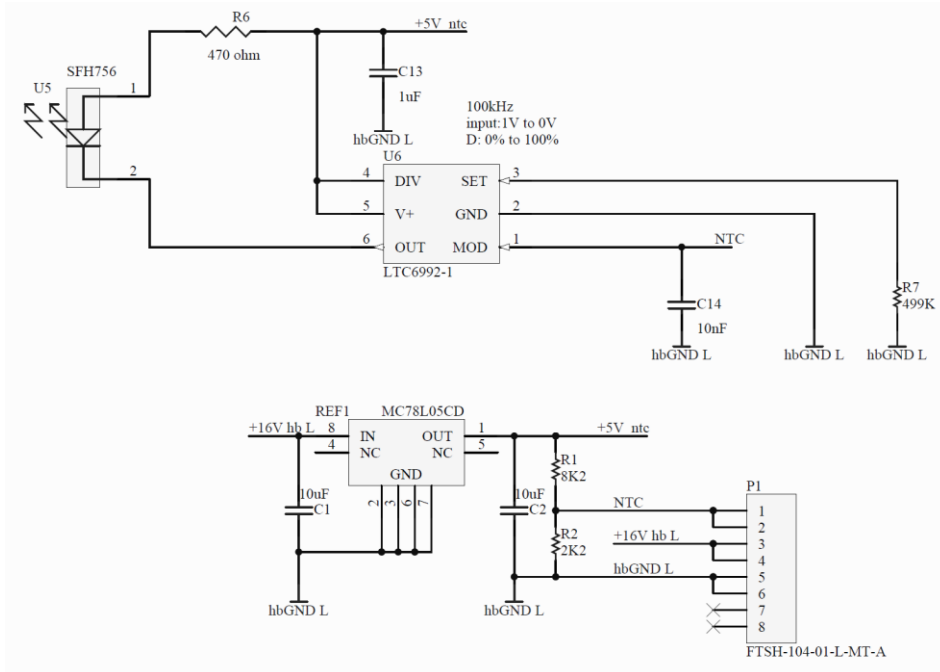

Figure18:Temperature card schematic

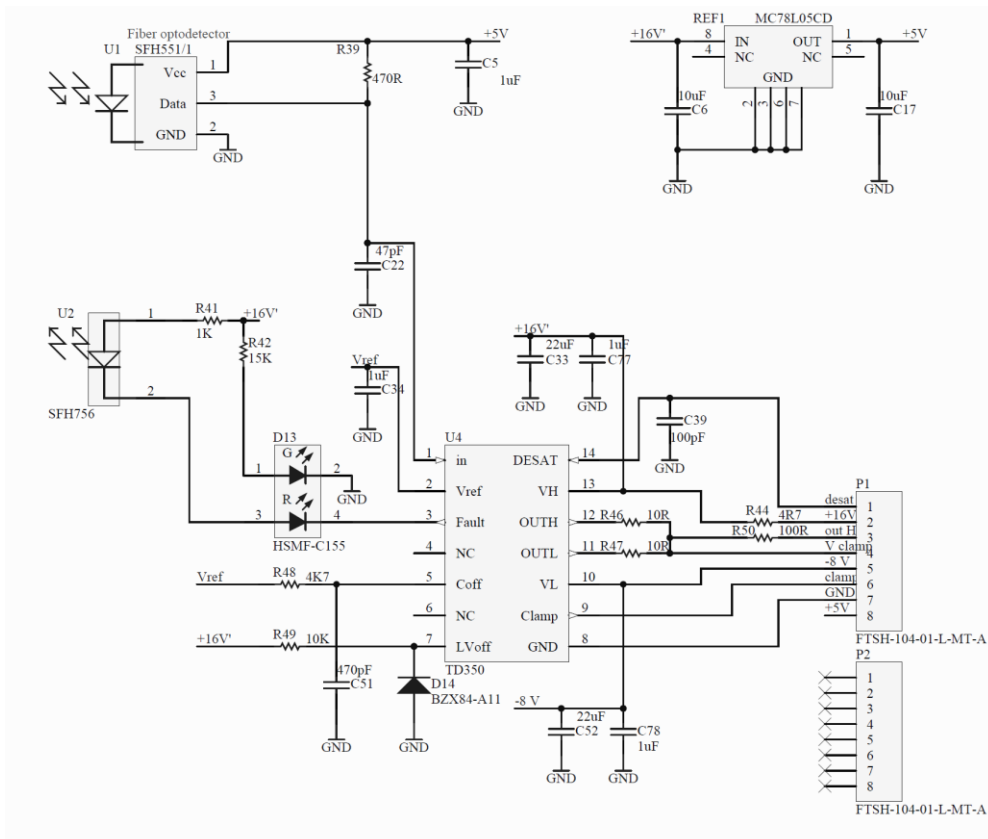
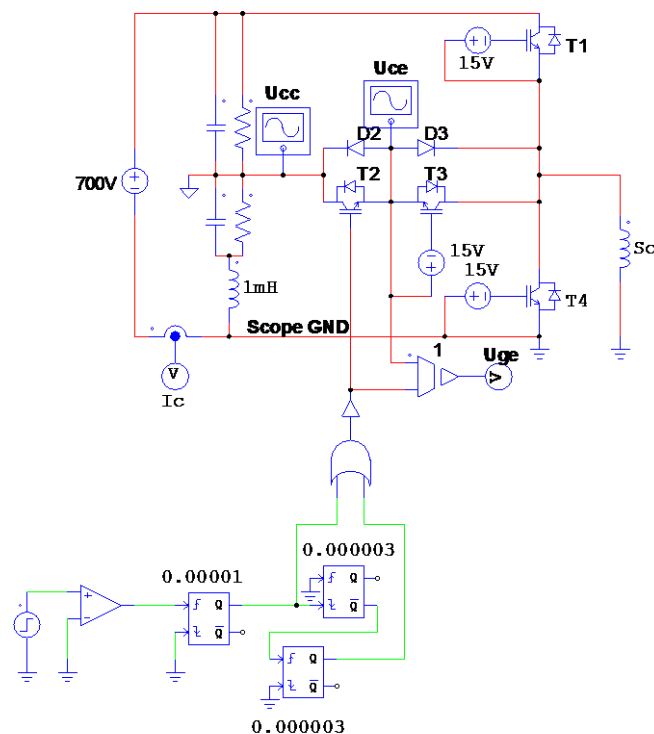

Figure19:Control card schematic

Short Circuit Protection

The short circuit protection has been tested by using critical inductance for the short (Sc). Critical inductance means that the inductance is so small that di/dt is high enough not to be able to be detected by the current sensing of the inverter. On the other hand the inductance is so big that the IGBT can temporary saturate due to the high di/dt and so the IGBT has to withstand du/dt after the short circuit protection is activated by the desaturation sensing.



The interpretation of the curves is the following.

At „0“ time the T2 IGBT is getting a positive gate voltage and it saturates. The emitter voltage, „magenta“ rises to the collector voltage, „green“. The current, „blue“ on the short circuit impedance starts to increase rapidly. Current range is 1000A / DIV. At about 4000A collector current the IGBT desaturation sensing is activated and the soft turn off is initiated, At „1“ time the gate drive circuit switches to the first turn off level of 10Vs. At time „2“ the IGBT desaturates in a soft manner due to the reduced gate drive voltage and the gate drive settles to 10V. As the IGBT is not turned off, there is no dangerous du/dt to cause RBSOA infringement and the overvoltage spike on the IGBT is also small. The short circuit current at a value of about 5000A partly commutes into the freewheeling diode (inverse diode of T4). The IGBT is conducting a current limited by its transfer current characteristics at 10V gate voltage. At time „3“ the IGBT gate voltage is totally switched off to -8V and the IGBT releases the rest of current. As the majority of the short circuit current is already flowing through the freewheeling diode and as there is no voltage change on the IGBT (du/dt) at this moment there will be no dangerous voltage overshoot and turn off safe operating area for the IGBT will be fulfilled.

30-Sep-13
17:34:00

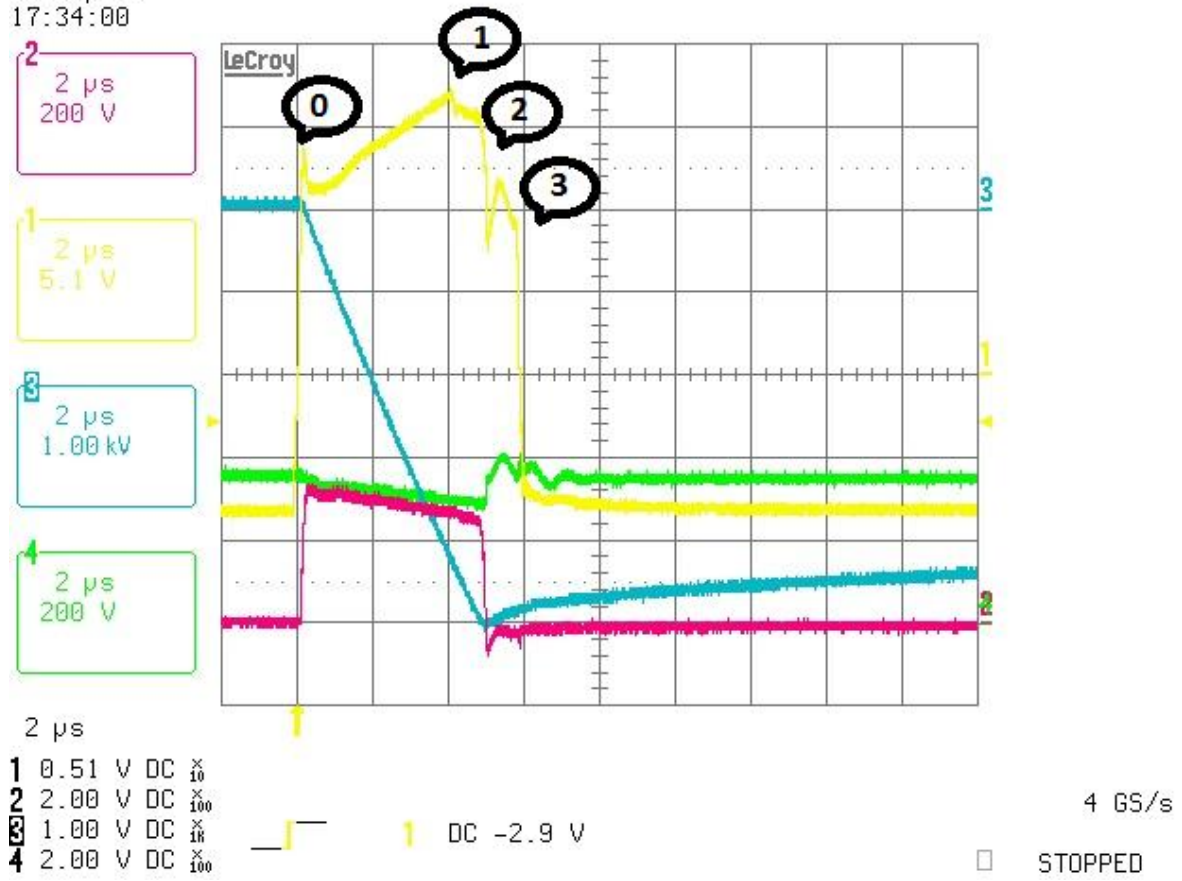
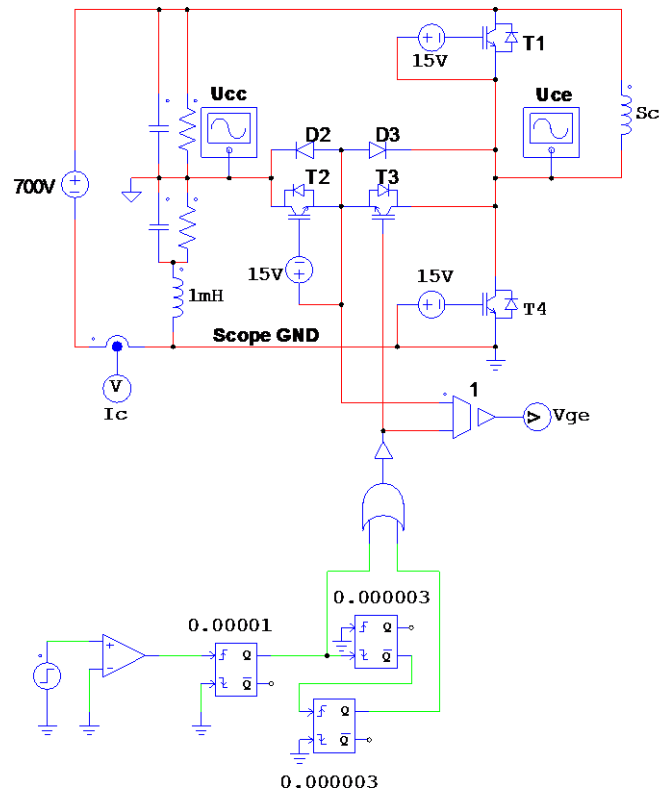

Figure 13: Schematic and waveforms of T2 NP high IGBT short circuit measurement

The short circuit protection is checked for all 4 IGBTs.



30-Sep-13
17:19:14

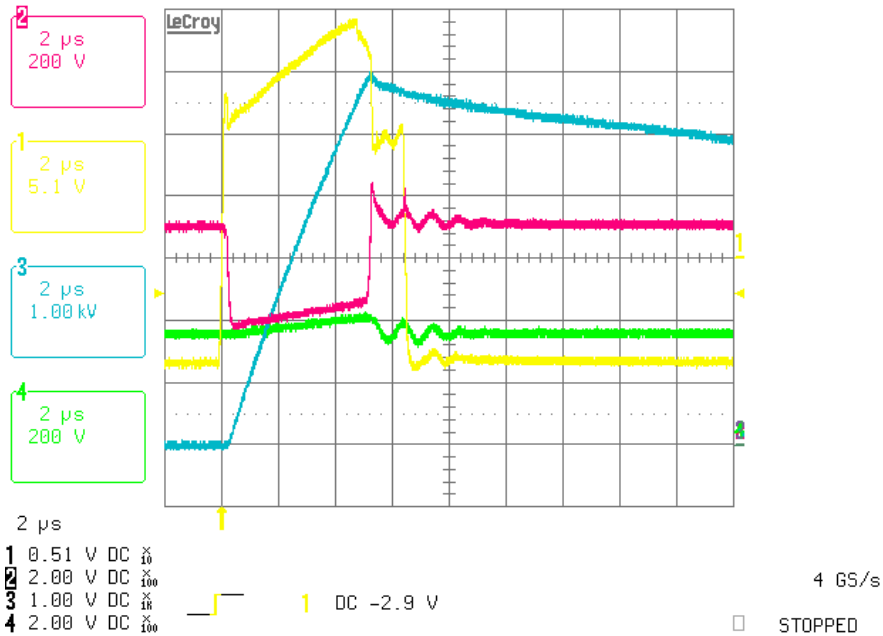
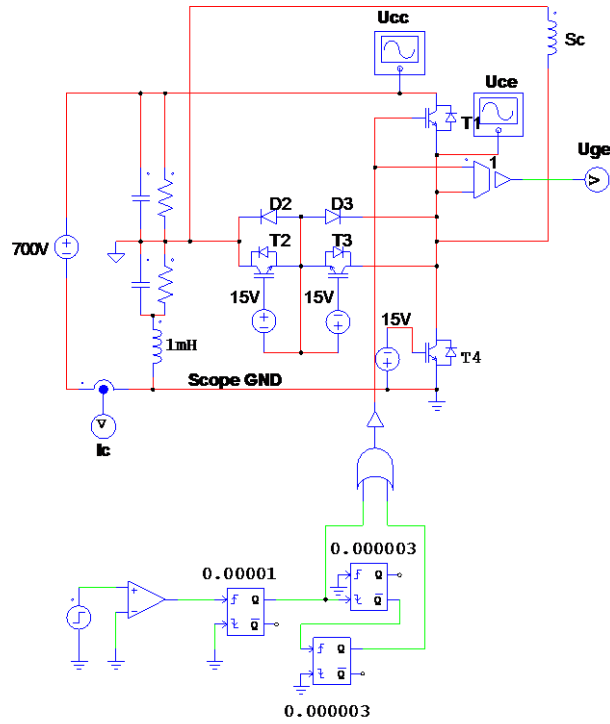

Figure 14: Schematic and waveforms of T3 NP low IGBT short circuit measurement



30-Sep-13
17:49:06

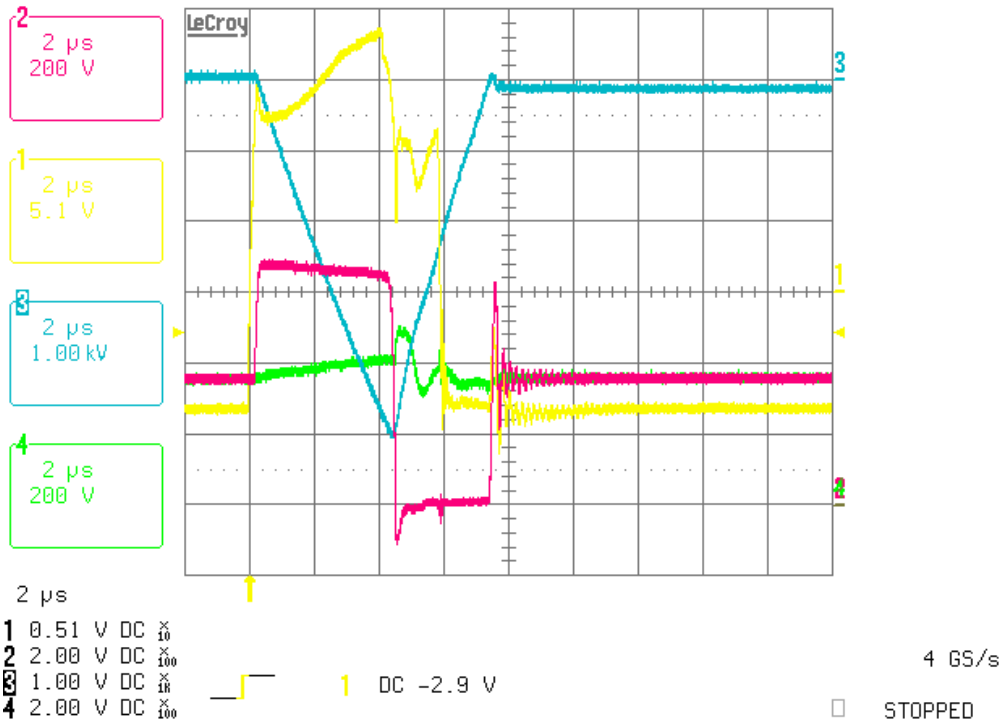

Figure 16: Schematic and waveforms of T1 HB high IGBT short circuit measurement

5 BOM

5.1 BOM Control Module

Part Number	Description	Material group	Quantity	Un	Layout position
312060	CGD-M400-PCB_CTR(Rev02); SAMPLE	PCB	1	PC	PCB
300737	C-1uF-25V-10%-X7R-0805-PM	Capacitors below 500V	4	PC	C5; C34; C77; C78
303142	C-10uF-25V-10%-X7R-1206-PM	Capacitors below 500V	2	PC	C6; C17
310998	C-47pF-100V-NPO-0805-PM; SAMPLE	Capacitors below 500V	1	PC	C22
310840	C-22uF-25V-10%-X7R-1210-PM	Capacitors below 500V	2	PC	C33; C52
311040	C-100pF-50V-10%-X7R-0805- PM; SAMPLE	Capacitors below 500V	1	PC	C39
300774	C-470pF-50V-5%-COG-0805- CM(I)	Capacitors below 500V	1	PC	C51
310999	LED-HSMF-C155-(Red/Green)- SMD-PM; SAMPLE	LEDs	1	PC	D13
303928	DI-BZX84C10-SOT23	Diode zener	1	PC	D14
311008	CONNECTOR-8PIN-1.27mm- MT-PM; SAMPLE	Connectors	2	PC	P1, P2
300748	R-470R-1%-TK100-0805-CM(I)	Resistors	1	PC	R39
300749	R-1K-1%-TK100-0805-CM(I)	Resistors	1	PC	R41
303237	R-4K7-1%-0805-PM	Resistors	1	PC	R48
300818	R-4R7-1%-TK100-0805-CM(I)	Resistors	1	PC	R44
311031	R-10R-1%-TK100-0805;Sample R-15K-1%-TK100-0805-PM; SAMPLE	Resistors	2	PC	R46, R47
310982	300758 R-10K-1%-TK100-0805- CM(I)	Resistors	1	PC	R42
300758	R-100R-1%-TK100-0805; Sample	Resistors	1	PC	R49
311323	R-100R-1%-TK100-0805; Sample	Resistors	1	PC	R50
310408	MC78L05ACDR2G; Sample	IC	1	PC	REF1
311004	SFH551/1-1V-PM; SAMPLE	IC	1	PC	U1
311005	SFH756V-PM; SAMPLE	IC	1	PC	U2
311006	IC-TD350ID-SO14-PM;Sample	IC	1	PC	U4

5.2 BOM Thermal Module

Part Number	Description	Material group	Quantity	Un	Layout position
312057	CGD-M400-PCB_TH(Rev02); SAMPLE	PCB	1	PC	PCB
303142	C-10uF-25V-10%-X7R-1206-PM	Capacitors below 500V	2	PC	C1, C2
300737	C-1uF-25V-10%-X7R-0805-PM	Capacitors below 500V	1	PC	C13
300780	C-10nF-50V-10%-X7R-0805- CM(I)	Capacitors below 500V	1	PC	C14
311008	CONNECTOR-8PIN-1.27mm- MT-PM; SAMPLE	Connector	1	PC	P1
311043	R-8K2-0.1%-TK25-0805-PM; SAMPLE	Resistors	1	PC	R1
311044	R-2K2-0.1%-TK25-0805-PM; SAMPLE	Resistors	1	PC	R2
300748	R-470R-1%-TK100-0805-CM(I)	Resistors	1	PC	R6
311029	R-499K-1%-TK100-0805 PM; SAMPLE	Resistors	1	PC	R7
310408	MC78L05ACDR2G; Sample	IC	1	PC	REF1
311005	SFH756V-PM; SAMPLE	IC	1	PC	U5
311030	IC-LTC6992CS6-1-SOT363-6L- PM; SAMPLE	IC	1	PC	U6

5.3 BOM Power Supply Module

Part Number	Description	Material group	Quantity	Un	Layout position
312202	CGD-M400-PCB_IN(REV03)	PCB	1	PC	
310998	C-47pF-100V-NPO-0805-PM	Capacitor	2	PC	C45,C46
310840	C-22uF-25V-10%-X7R-1210-PM	Capacitor	48	PC	C0-C33,C35- C44,C100,C111,C112,C133
311013	CONNECTOR-10PIN-1.27mm- FTSH10-PM	Connector	4	PC	HB_H_1,HB_L_1,NP_H_1,NP_ L_1
311010	CONNECTOR-8PIN-1.27mm- FLE8-PM	Connector	4	PC	HB_H_2,HB_L_2,NP_H_2,NP_ L_2
311879	IC-IGC136- 15W_DC/DC_CONVERTER	IC	4	PC	IG126_15-IG126_18
311014	CONNECTOR-2PIN-2.5mm- HDR1X2-PM	Connector	1	PC	P17

5.4 BOM Current Booster Module

Part Number	Description	Material group	Quantity	Un	Layout position
312203	CGD-M400-PCB_OUT(REV03)	PCB	1	PC	PCB
310840	C-22uF-25V-10%-X7R-1210-PM	Capacitor	24	PC	C1-C8,C13-C24,C29-C32
300737	C-1uF-25V-10%-X7R-0805-PM	Capacitor	4	PC	C25,C34,C36,C37
300781	C-100nF-50V-10%-X7R-0805-CM(I)	Capacitor	4	PC	C33,C35,C38,C39
311039	DI-EGF1T-E3/67A-DO214BA-PM; SAMPLE	Diode	4	PC	D1,D2,D9,D10
312067	DI-P6SMB18CA-18V-600W-SMB; Sample	Diode	8	PC	D3-D6,D11-D14
311038	DI-VS-10BQ100PBF-SMB-PM; SAMPLE	Diode	4	PC	D7,D8,D15,D16
312068	DI-P6SMB480A-480V-600W-5%-SMB; Sample	Diode	8	PC	D17,D18,D23,D24,D33-D36
310866	BAS385 30V,200mA MICROMELF; Sample	Diode	12	PC	D19-D22,D25-D32
311041	CONNECTOR-8PIN-1.27mm-SMD-FTSH8; SAMPLE	Connector	4	PC	HB_H,HB_L,NP_H,NP_L
312069	TR-ZXTP25040DFH-PNP-SOT23; Sample	Transistor	4	PC	Q1-Q4
300749	R-1K-1%-TK100-0805-CM(I)	Resistor	4	PC	R2,R23,R24,R47
312070	R-8R2-1%-TK100-0603; Sample	Resistor	12	PC	R3,R4,R13-R16,R25,R26,R35-R38
311033	R-R510-1%-TK100-1210-PM; SAMPLE	Resistor	20	PC	R5-R12,R21,R22,R27-R34,R43,R44
310982	R-15K-1%-TK100-0805-PM; SAMPLE	Resistor	8	PC	R17-R20,R39-R42
300672	R-1R-1%-TK100-0805-CM	Resistor	4	PC	R45,R48,R51,R52
311031	R-10R-1%-TK100-0805-PM; SAMPLE	Resistor	4	PC	R1,R46,R49,R50
311036	TR-ZXGD3006E6-SOT23-6-PM; SAMPLE	IC	8	PC	T1-T8